

Electronics-Salon

Independent 8 Channels Thermal Circuit Breaker Module.

Model: D-1192

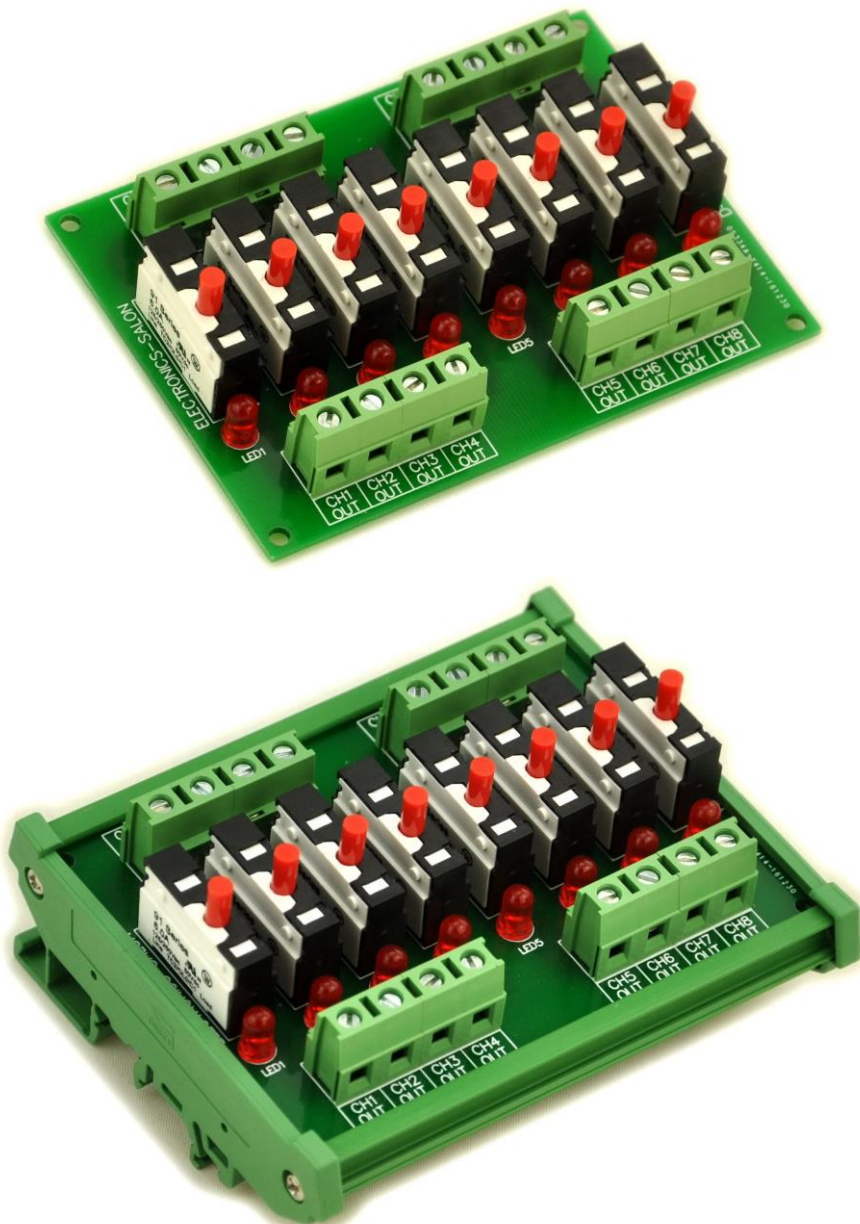

1, Version:

Panel mount ---- MD-D1192

DIN rail mount ---- MD-D1192T

2, Dimensions:

MD-D1192

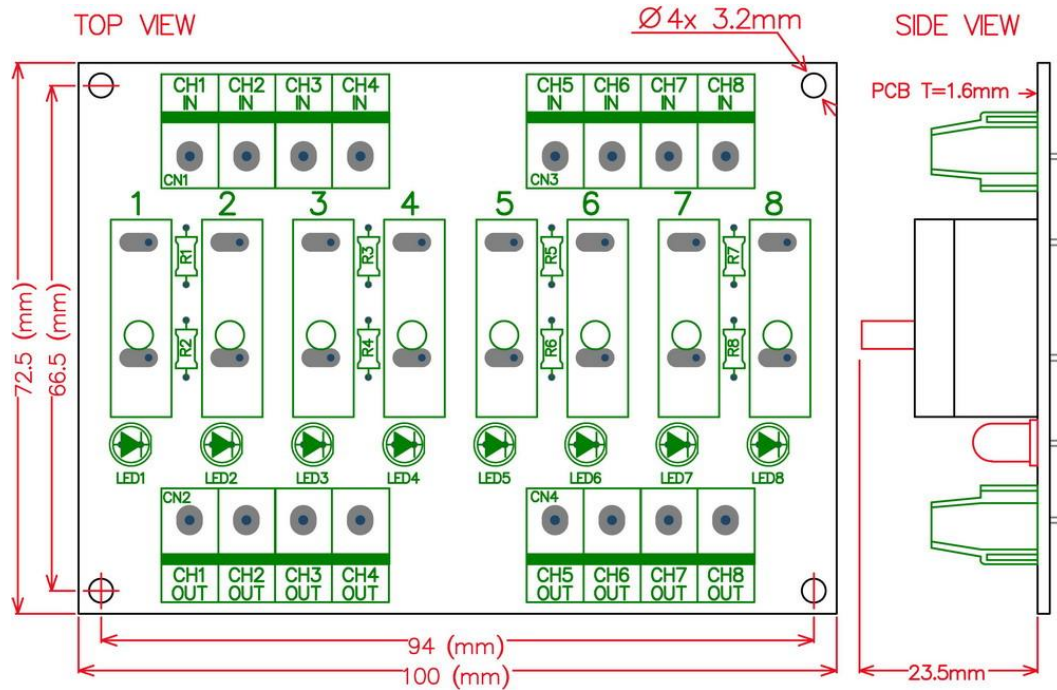

MD-D1192T

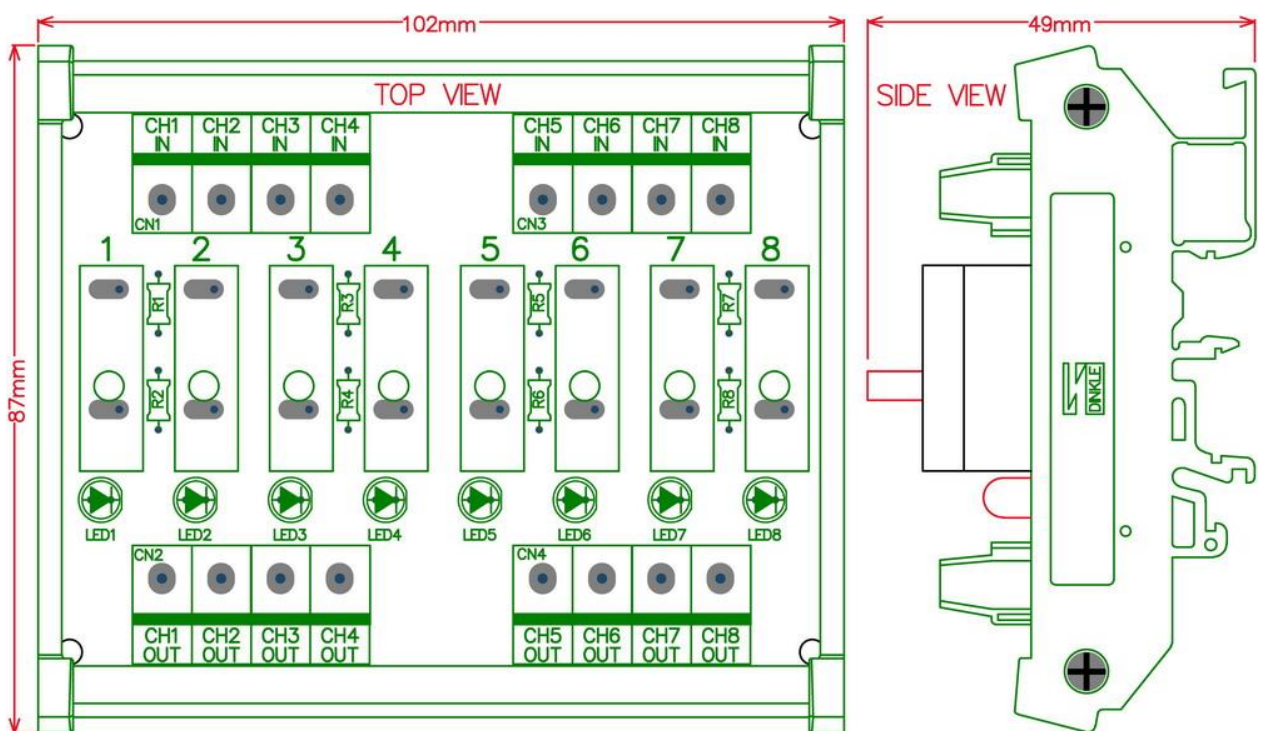

3, Schematic:

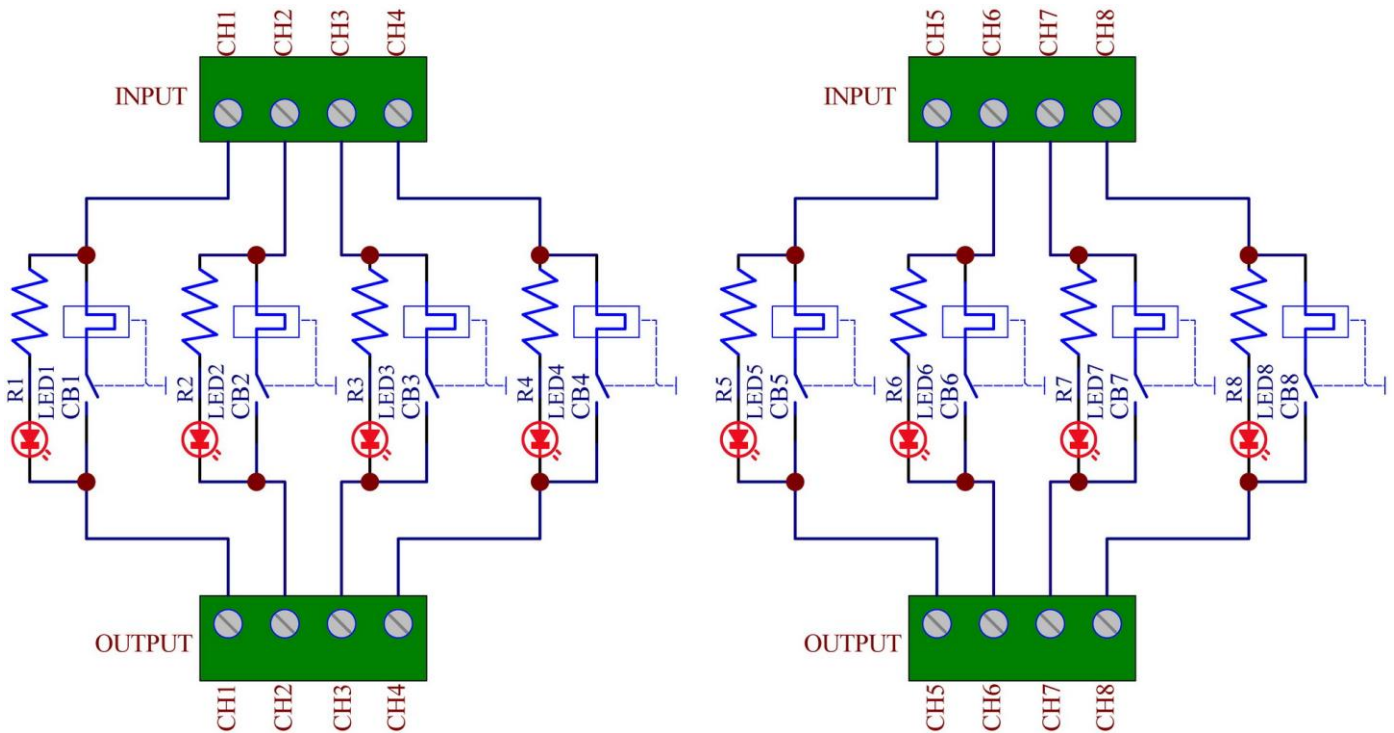

4, Terminal block:

Pitch - 7.5mm/0.295", wire size 26~12 AWG, stripping length 7mm, Metric M2.5 slotted screw.

5, DIN rail mount version carrier:

High quality Taiwan DINKLE fireproof nylon material DIN rail mount carrier (not China low quality carrier), can support width 35mm / 32mm / 15mm rails.

6, Specification:

Work voltage ---- DC 24 ~ 50V, AC 125V / 250V.

Input to output maximum current (per channel) ---- 6 Amp.

LED ---- connected load, when circuit breaker off, led will on.

Circuit breaker reset mode ---- manual reset (push to reset).

Current breaker value: 6 Amp.

Trip Time Curves

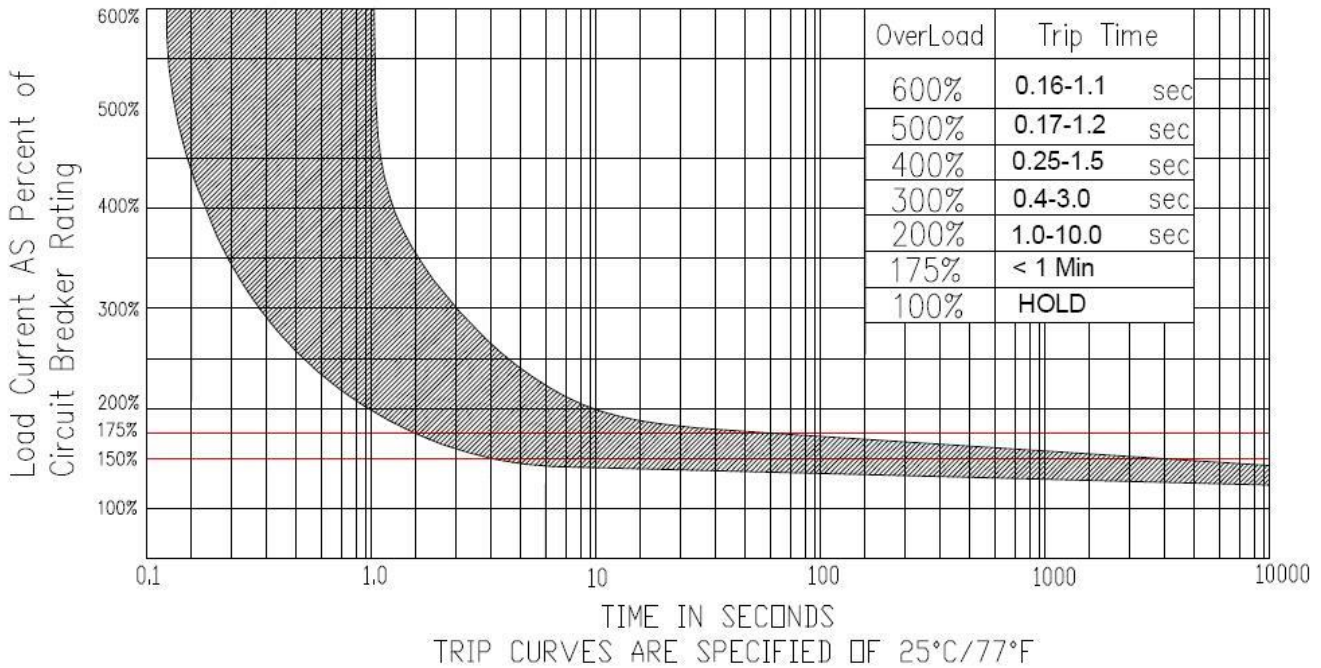

Ambient Temperature Correction Factor

The time/current characteristic curve depends on the ambient temperature prevailing. In order to eliminate nuisance tripping, please multiply the current breaker current ratings by the derating factor shown below.

Ambient temperature	-10°C	0°C	10°C	25°C	40°C	50°C	60°C
Multiplication factor	1.30	1.20	1.10	1.00	0.85	0.73	0.60