

DIGITAL MULTIMETER OPERATION MANUAL

1. SUMMARIZE

It is a handheld small and safe digital multimeter with 3 1/2 digits, full function and high performance for measuring DCV, ACV, DCA, resistance, capacitance, diode, continuity test, thus it is a portable and ideal tool for users. Please read the safety information and warning in this manual carefully, and strictly abide by it.

2. OPEN THE PACKAGE

Open the box, take out the meter, and then

1

use it. If you found the insulation surface of the test leads or the cover of the meter is obviously damaged, or you think it can't work anymore, please do not use the meter again.

3-2. When you using the test leads, your fingers should be put after the finger protective part.

3-3. When the voltage under tested is higher than DC 36V and AC 25V RMS, be careful to prevent electric shock.

3-4. Do not operate the meter if battery case

and back cover is not fixed.

3-5. The signal under tested should not be over range, in case to avoid the electric shock.

3-6. It is forbidden to change the range by the range knob under measurement.

3-7. Do not test the voltage by connecting the current terminal or at the current range.

3-8. When replacing fuses, please use the same type and specification fuses.

3-9. Do not change the inner circuit of meter, to avoid damage of the meter.

3-10. When the LCD displays  symbol,

check the items below to make sure if they are missing or damaging:

Manual	1pc
Test lead	1pair
1.5V AAA LR03 Battery	2pcs
Holster	1pc

Please contact with your supplier, if you find out any problems.

3. SAFETY NOTE

Please pay attention to the warning which indicates a situation or action that poses a danger to the user and may cause damage to

2

replace the batteries in time to ensure the measuring accuracy.

3-11. Please comply with local and national safety regulations. Wearing personal protective equipment (such as approved rubber gloves, face masks, and flame-retardant clothing etc.) to prevent the injury from electric shock and arc when charged conductors are exposed.

3-12. Do not store and operate the meter under the condition of high temperature, high humidity, combustible (flammable),

the instrument or the equipment under test. The instrument strictly follows GB4793.1 safety requirements for electric instruments and safety standard IEC61010 to design and produce, which is under the safety standards of double insulation, overvoltage standards (CAT II 1000V, CAT III 600V) and pollution level 2. Please read the operation manual carefully before operation, or the protection function will weakened or lost.











3-1. Please check whether the insulation surface of the test leads is intact before

3

explosive and strong magnetic place.

3-13. Wipe the case with a damp cloth and detergent, do not use abrasives and alcohol etc.

4. SAFETY SYMBOLS

	Warning
	High Voltage danger
	Ground
	Dual insulation
	Low battery Voltage
	DC
	AC
	AC and DC
	Accord with order of the European Union
	Fuse

5. CHARACTERISTIC

5-1. Display : LCD displaying.

5-2. Max display: 1999 (3 1/2 digit) auto polarity indication.

5-3. Measuring method: A/D conversion

5-4. Exploit the technology of button calibrating

5-5. Sampling rate: approx.3 times/second.

5-6. Over range indication: the MSD displays "OL"

5-7. Low battery indication: "🔋" appears.

5-8. Operation environment: (0~40) °C

relative humidity < 75% R.H

5-9. Storage environment: (-20~60) °C

relative humidity < 85% R.H.

5-10. Power: 2 * AAA 1.5V LR03 batteries

5-11. Size: (146*72*50) mm

5-12. Weight: about 232g

6. EXTERNAL STRUCTURE

6-1. Sound alert indicator

6-2. LCD display

6-3. Function / range knob

6-4. Measuring input terminal

8. KEY DESCRIPTION

8-1. Data hold:

Short press "HOLD" key, the present value will keep on the LCD, press this key again to exit this function.

⚠️ ⚠️ Warning: to prevent electric shock, fire or personal injury, do not use the data hold function to measure the unknown voltage. When open the HOLD function, the LCD will keep original data when measuring a different voltage.

8-2. Backlight function:

Short press the "B/L" key to turn on/off the backlight, it will be auto powered off after 15 seconds since the back light is on.

8-3. Turn on/off the "REL/ 🔦" function:

Short press the "REL / 🔦" key at ACV, DCV, DCA, capacitance range, at the relative value measurement mode, the symbol "REL" displays on the LCD at the same time. Long press the "REL / 🔦" key to open the torch, then long press this key again to turn off the torch.

8-4. Cancel the auto power off function

6-5. Data hold

6-6. Turn on/off the back light

6-7. Relative value measurement; Turn on/off the torch

6-8. NCV sensing area

6-9. Holder

6-10. Screws for fixing the battery box

6-11. Bracket for fixing the test leads

7. LCD DISPLAY



Press the REL key to turn on the meter, the "APO" symbol disappears, and then the auto power off function closed.

9. MEASUREMENT INSTRUCTIONS

First of all, please check the battery, and turn the knob to the proper range that you need. If the battery is out of power, the "🔋" symbol will appear on the LCD. Pay attention to the ⚠️ symbol next to the jack for test leads.

This is a warning that the voltage and current should not exceed the displaying value.

APO	Auto power off
DC	Direct current measurement
H	Data hold
🔋	Battery low voltage
REL	Relative value measurement
▶️ 	Diode/continuity test
mmFVA	Capacitance, voltage, current
AUTO	Auto range
AC	Alternating current measurement
NCV	Non-contact ACV measurement
°C°F	Celsius, Fahrenheit
⚡	High voltage
%	Duty cycle
MkΩHz	Resistance, Frequency

9-1. DCV and ACV measurement

9-1-1. Set the range knob to a proper DCV/ACV range, if the range of voltage under tested is unsure beforehand, you should set the range knob to the highest range, then reduce it gradually until get the highest resolution readings.

9-1-2. Insert the black test lead to "COM" jack, the red one to **VΩHz mA** jack.

9-1-3. Connect the test leads to the test point, the LCD displays the voltage value under tested. When measuring DCV, the polarity

and the voltage value of this point which connects to the red test lead will display on the LCD.

NOTE:

- (1). Do not measure voltage higher than 600V, although it is possible to get the reading, it will damage the inner circuit and hurt yourself. If the range of voltage under tested is unsure beforehand, please start from the highest range then find the proper range according to the reading.
- (2). If LCD displays “OL”, it means over

electric shock,

- (2). Be sure to cut off the power under tested before measurement, carefully check whether the input terminal and the range knob position are correct, then power on the meter and operate after confirming everything is no problems. If the range of current under tested is unsure beforehand, should set the range knob to the highest range, and then reduce it gradually.
- (3). Input overload at the mA input jack will blow the built-in fuse, in this case the fuses

- range, you should set the range knob to a higher range. In each range, the input impedance of the meter is $10M\Omega$. This load effect will cause measuring error when measuring the high resistance circuit. If the impedance of the circuit under test is less than $10k\Omega$, the error can be ignored (0.1% or less than 0.1%)
- (3). After completing all the measurement operation, please disconnect the test leads from the circuit under test.
 - (4).When measuring more than 24V AC/DC,

should be replaced. The dimension of the fuse is $\phi 5*20mm$, and the electrical specification is 200mA / 250V. There's no built-in fuse for the 10A input jack, for safe use, each measuring time should be less than 10s, interval time should be more than 15 mins.

9-3. Resistance measurement

- 9-3-1. Set the range knob to a proper resistance range, and connecting the test leads across to the resistance under measured.

the LCD will show high voltage symbol. Please wear personal protective equipment (such as approved rubber gloves, face masks, and flame-retardant clothing etc.) to prevent the injury from electric shock and arc when charged conductors are exposed.

9-2. DCA measurement

- 9-2-1. Set the knob to a proper range, and then connecting the test leads to the circuit under test in series. When measuring DC value, the polarity and the current value of this point which connects to the red test lead

- 9-3-2. Insert the black test lead to “COM” jack and the red one to “” jack.

NOTE:

- (1). When measuring in-line resistance, be sure the circuit under tested has been switched off and all capacitors are fully discharged.
- (2). At range 200Ω , the test leads lead will cause $0.1\sim 0.3\Omega$ resistance measuring error. In order to get the accurate result, short-circuit the test leads to measure the

will display on the LCD.
9-2-2. Insert the black test lead to “COM” jack, the red one to “” or “10A”jack.

NOTE:

- (1). Although for the current which is less than 200mA we have set the overvoltage protection, when the measured voltage between the input terminal and the ground exceeds 60V, do not try to measure the DCA value, to avoid damage to the instrument or the device under tested and hurt yourself. This kind of voltage will bring the risk of

wire resistance, then subtracts it from the reading.

- (3). When the resistance is over $1M\Omega$, the meter may take a few seconds to stabilize. This is normal for high resistance readings.
- (4). Do not input any voltage at resistance range.

9-4. Capacitance measurement

- 9-4-1. Set the range knob to a proper capacitance range, connect the test leads to the capacitor under tested (note: the polarity of red test lead is

“+”),

9-4-2. Insert the red test lead to “**VΩHz mA**” jack and the black one to “COM” jack.

NOTE:

- (1). If the LCD displays "OL", it indicates the value is over range. The maximal range is 200 μ F.
- (2). When measuring the capacitance which is below 20nF, there is a remained value on LCD, which is the distributed capacitance of test leads. You can press “REL” key to do the relative value

measurement to get a more accuracy value.

- (3). When measuring a capacitor which is broken or leakage, the LCD will show some unstable value; when measuring a large capacitance, you need a few seconds to get a stable reading, this is quite normal.
- (4). Discharge all capacitors completely before capacitance measurement to avoid the damage of the meter.
- (5).UNIT: 1mF=1000uF 1uF =1000nF

1nF=1000pF

9-5. Diode and continuity test

- 9-5-1.Insert the black test lead to “COM” jack, and the red one to “**VΩHz mA**” jack.
- 9-5-2. Set the range knob to the diode/continuity test range. (The range diode/continuity test is auto conversion) Connect the red test lead to the positive of the diode and the black one to the negative.
- 9-5-3. the reading on LCD is the diode positive voltage drop. If mistake the

polarity, it will show “OL” on LCD.

9-5-4.Connect the test leads to two ends of the measured circuit, if the resistance is lower than approx. (50±20) Ω, the buzzer sounds.

Note:

To avoid the damage of the meter, before measuring diode in-line, be sure the power has been switched off and all capacitors are fully discharged. The diode range can be measured the voltage drop of the diodes and other semiconductor

component. For a normal structure of silicon semiconductor, the forward voltage drop should be 0.5V ~ 0.8V. If you mistake the test leads connection, it will display "OL" and means it is an open circuit. Now the black test lead connect to the "+", and the red one to "-".

9-6. Non-contact voltage sensing measurement NCV

- 9-6-1. Set the knob to NCV range
- 9-6-2. The NCV sensing voltage range is 48V~220V. Put the upper part of the

meter close to the AC power line under test. When sensing the voltage of AC line, the red indicator will flash on the upper part of the meter and the buzzer will sound. The closer the AC power line is, the stronger the voltage of AC line shows, the faster the indicator flashes and buzzer sounds.

9-7. Auto power off

In order to save the battery energy, auto power off function already set by default when you turn on the meter, if you have

no any operation in 14 minutes, the meter will beep for three times to hint, if there’s still no any operation, the meter will long sound and auto power off after one min..

10. TECHNICAL CHARACTERISTIC

Accuracy: ±(a%×rdg + d) at (23±5)°C, R.H. <75%

10-1. DCV

Range	Accuracy	Resolution	Overload protection
200mV	±(0.5%+5)	0.1mV	250V DV/AC rms

2V	±(0.5%+3)	0.001V	600V DV/AC rms
20V		0.01V	
200V		0.1V	
600V	±(1.0%+10)	1V	

Input impedance: About 10MΩ

10-2. ACV True RMS measurement

Range	Accuracy	Resolution	Overload protection
200V	±(1.2%+10)	0.1V	600V DV/AC rms
600V		1V	

Input impedance: About 10MΩ

⚠ Measuring scope of accuracy: 10% - 100% of the range; Frequency response: 40Hz-1kHz

Measuring way(sine wave): True RMS

Crest factor: $CF \leq 3$, when $CF \geq 2$, add an additional error of 1% of the reading

10-3. DCA

Range	Accuracy	Resolution	Load voltage
200uA	$\pm(1.0\%+10)$	0.1uA	0.1mV/uA
200mA	$\pm(1.2\%+8)$	0.1mA	3.64mV/mA
10A	$\pm(2.0\%+5)$	0.01A	16.3mV/A

⚠ Max. Input current: 10A (less than 10s)

Overload protection: 200mA/250V fast-melt fuse, no fuse at the 10A range.

Measuring time: Should be less than 10 seconds; Interval time: Should be more than

32

15 minutes

10-4. Resistance (Ω)

Range	Accuracy	Resolution	Short-circuit current
200 Ω	$\pm(0.8\%+5)$	0.1 Ω	About 0.3mA
2k Ω	$\pm(0.8\%+3)$	0.001k Ω	About 0.3mA
20k Ω		0.01k Ω	About 80uA
200k Ω		0.1k Ω	About 10uA
2M Ω	$\pm(1.0\%+5)$	0.01M Ω	About 1uA
200M Ω	$\pm(5.0\%+30)$	0.1M Ω	About 0.1uA

⚠ Measuring error does not include lead resistance

Overload protection: 250V DV/AC RMS

fuse, then replace with a new battery or a new fuse.

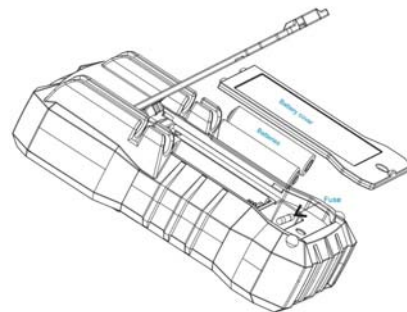

11-4. Close the battery cover and use a screwdriver to tighten the screws on the battery cover.

11-5. Battery specifications: 1.5V * 2 AAA LR03.

37

Open-circuit voltage: About 0.5V at range

200M Ω , and about 1V at other range.

10-5. Capacitance (C)

Range	Accuracy	Resolution	Overload protection
200uF	$\pm(5.0\%+10)$	0.1uF	250V DV/AC rms

⚠ Measuring scope of accuracy: 10% - 100% ;

Large capacitance response time: ≥ 1 mF, about 8s, measuring error does not include lead resistance

11-6. Fuse specifications: mA input fuse

"FS1": $\phi 5 * 20$ mm 200mA/ 250V

Note: When the low voltage " " symbol displays on the LCD, the battery should be replaced immediately, otherwise the measuring accuracy will be affected.

12. MAINTENANCE AND CARE

It is an accurate meter. Do not try to modify the electric circuit.

12-1. Beware of waterproof, dust-proof and shockproof.

38

10-6. Diode and continuity test

Range	Displaying value	Test condition
→))	Positive voltage drop of diode	Measuring current: about 0.4 mA Open circuit voltage: about 2V
	Buzzer sounds long, the resistance of two points is less than $(50 \pm 20)\Omega$	Measuring current: approx. 0.2mA

Overload protection: 250V DV/AC RMS

Testing Accuracy: 5%

⚠ Warning: Do not input any voltage at this range.

35

11. BATTERIES AND FUSE REPLACEMENT

If the " " symbol displays on the LCD, it means the battery needs to be replaced, please follow below steps:

11-1. Move the test leads from the circuit under test, pull out the test lead from the input jack, and turn the range knob to "OFF".

11-2. Use a screwdriver to twist off the screws on the battery cover, and remove the battery cover and bracket.

11-3. Take out the old battery or the broken

36

12-2. Do not operate and store the meter in the circumstance of high temperature, high humidity, and flammability, explosive and strong magnetic field.

12-3. Use the damp cloth and soft solvent to clean the meter, do not use abrasive and alcohol.

12-4. If you do not operate it for a long time, you should take out the battery.

12-5. When replacing the fuses, please use the fuse with the same type and specification.

39

13. Troubles

If the meter does not work properly, check the meter as following:

Condition	Solutions
No reading on LCD	<ul style="list-style-type: none">●Turn on the meter●Replace battery
 symbol displays	<ul style="list-style-type: none">●Replace battery
No current input	<ul style="list-style-type: none">●Replace fuse
Error value	<ul style="list-style-type: none">●Replace battery
Dark displaying	<ul style="list-style-type: none">●Replace battery

This user's manual is subject to any change without further notice.

The content in this user's manual is deemed correct; if you find any mistake, omission, etc, please contact the manufacturer.

We will not be held liable for any accidents or harms caused due to your wrong operations.

The functions set forth in this user's manual shall not be regarded as reasons for applying this product for special purposes.

601C-0202-000B