

4. INSTALLATION INSTRUCTIONS

4.1 The tailstock installation

Use the screws to fix the bracket on the lamp

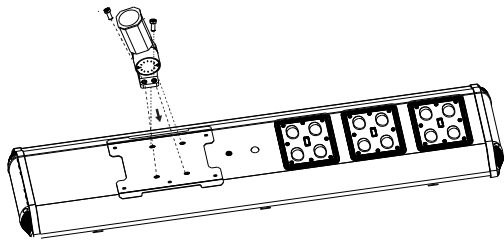

4.2 Light pole installed

Use the screws to fix the lamp on the post

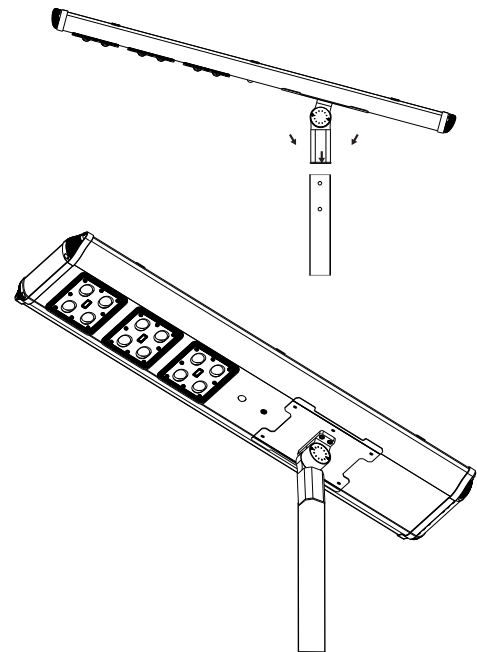

Successful installation

1. Integrated solar street lights can't work without sunshine, Please choose suitable product model according to the sunlight intensity of the installed area or amount of solar radiation, and choose product model according to the actual lighting needs ;In the area where the sun is not enough or long-time continuous rainy day, the working time of the solar light will be reduced, this lamp design is mainly based on African average illumination time;

2. If install this product in the northern hemisphere, make solar panels as possible towards the south, in order to get maximum light energy; If it is in the southern hemisphere, installing solar panels towards the north. At the same time to avoid the shadow of houses, trees and other obstructions which will reduce the efficiency of the solar panel and shorten its work time.

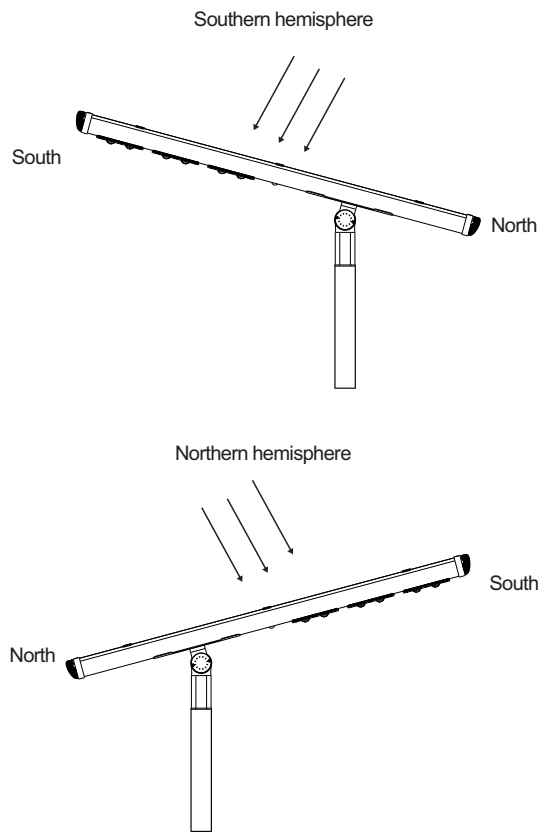

5. Warranty and after-service:

This product from the date of delivery, not artificial damage warranty for 60 months.



Make life full of hope

User Manual

F1 Series

All in one solar street light

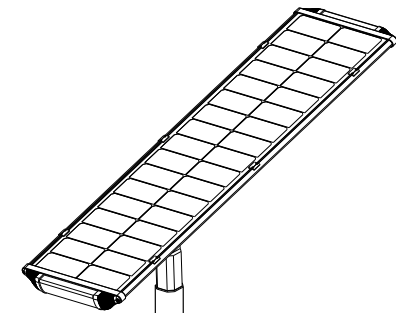

358-010229-01

1. INTEGRATED SOLAR STREET LIGHT INTRODUCTION

1.1 Integrated design and source, high capacity LiFePO4 lithium battery, high energy, and long life, light weights, green and environmental protection, do not produce any harmful substances.

1.2 Philips LED chip with high light efficiency which can reach 180LM/W, and whole lamp light efficiency can reach 160LM/W at least

1.3 All series use MPPT controller with high efficiency

1.4 Design with high efficiency solar cell (>22%)

1.5 Convenient installation and maintenance, no need of cable installation or special light pole, functional components modular design, installation and maintenance, convenient and quick replacement.

2. Part description

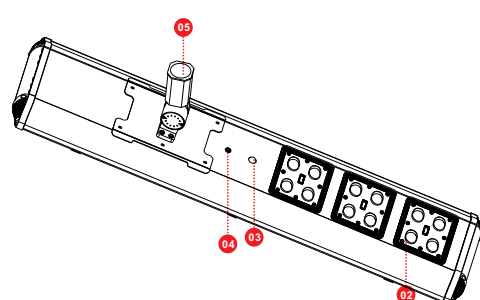
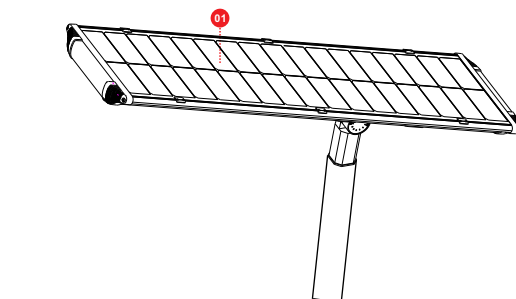

- 1. Solar panel
- 2. LED light
- 3. Body induction
- 4. Switch
- 5. Tailstock

3. The performance parameters

Model	F1-60W	F1-80W	F1-100W	F1-120W	Note
Solar module	85W(Mono)	95W(Mono)	105W(Mono)	110W(Mono)	
High capacity lithium battery	Built-in 532WH	Built-in 650WH	Built-in 888WH	Built-in 999WH	
luminous flux (All light pattern)	9600 lm	12800 lm	16000 lm	19200 lm	
Working Mode	Normal mode(default): 4H100% 4H50% 4H25% Induction mode(optional): No induction or customization				OEM according to the quantity
Solar panel charge time	8H strong sunlight				
Working	TimeAll light pattern	≥ 12 hours			
	Raining days backup	3 days			
Color temperature	6500K				
Induction angle	75°X 145°				
Light pole diameter	80mm				
Storage temperature	0-55℃				
Operating humidity	≤ 90%RH				
Working temperature	Charge temperature	0-55℃			
	Discharge temperature	-10℃-60℃			
Ingress Protection	Ip65				
Recommend Installation height	No	No	Yes	Yes	
Product Package dimensions	5-7M	6-8M	6-9M	6-9M	
Product Gross weight	1500*405*205mm	1745*405*205mm	1825*405*205mm	1905*405*205mm	2PCS/CTN
Tailstock Package dimensions	23.9 KG	27.3 KG	32.2 KG	35.2 KG	2PCS/CTN
Tailstock Gross weight	425*275*95mm				4PCS/CTN
	7.8 KG		8.6 KG		4PCS/CTN

Light distribution curve

