

# USER GUIDE

## Solar inverter

(IVPA Series )

*Solar inverter*



# Contents

<b>Advantage .....</b>	<b>01</b>
<b>Product Overview.....</b>	<b>02</b>
Product Overview.....	02
Product Overview.....	03
Connection diagram .....	03
<b>Wiring Diagram .....</b>	<b>04</b>
<b>Wiring System for Inverter .....</b>	<b>05</b>
<b>Parallel LCD Setting .....</b>	<b>10</b>
Setting items.....	10
<b>Commissioning.....</b>	<b>10</b>
<b>Dry Contact Signal .....</b>	<b>12</b>
<b>Specification.....</b>	<b>13</b>
Specification.....	13
<b>Front Panel .....</b>	<b>15</b>
<b>LCD Setting .....</b>	<b>16</b>
Setting items.....	17
Setting items.....	18
Setting items.....	19
<b>LCD Display Icons.....</b>	<b>20</b>
<b>In battery mode, it will present battery capacity.....</b>	<b>21</b>
<b>Display Information.....</b>	<b>22</b>
Display Information.....	23
<b>Fault Code Table.....</b>	<b>24</b>
Fault Code Table .....	25
Fault Code Table .....	26
<b>Warning Code Table.....</b>	<b>27</b>
<b>MPPT charger controller match to the Inverter .....</b>	<b>28</b>
MPPT charger controller match to the Inverter .....	29

# Advantage

- Bypass charging function: when the unit off, it can be activated with bypass output and can charge the battery.
- High charging current, the max charging current can be 200A for IVPA10048 and 180A for IVPA7548, 170A for IVPA5048, 120A for IVPA3524.
- Wide range of AC input voltage: the range of AC input voltage can be 90-280V for IVPA7548 and IVPA10048, 80-140V for IVPA5048 and IVPA3524. It can be better compatible with generator working. It is rare to have wide range input voltage for the power frequency inverter.
- Electricity and battery priority is optional: customer can choose Electricity or battery priority according to their needs.
- Battery self-defined: customer can set the overcharge voltage and float voltage, and over-discharge voltage.
- 50/60HZ compatible.
- Intelligent: Intelligent adjustment of over-discharge voltage, intelligent fine-tuning of over-discharge voltage according to the power of the load; intelligent cooling fan, intelligent adjustment of speed according to power and charging current and core temperature inside the machine.
- Safety: Safety design is upgraded overall. Comprehensive protection, such as over-charge protection/over-discharge protection/overload protection/output short-circuit protection/over-temperature protection, etc. Among them, transformer over-temperature protection is a leading design in the industry.
- Later it can communicate with our MPPT. And the electricity charging and solar charging can be managed comprehensively and scientifically.

Product Overview

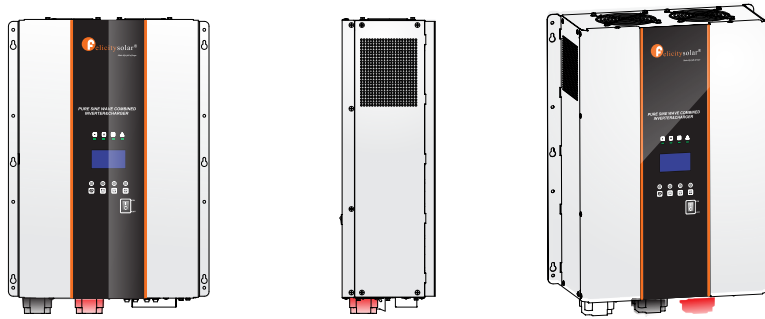

IVPA3524 TYPE

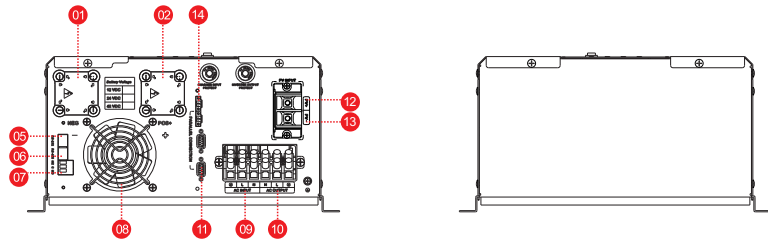

IVPA5048 TYPE

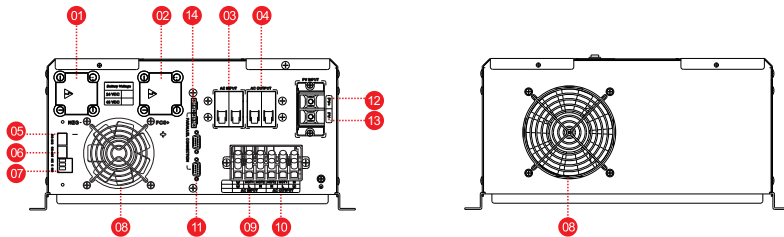

IVPA7548 TYPE

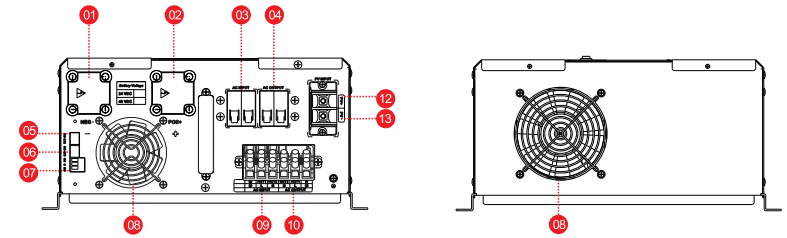

IVPA10048 TYPE

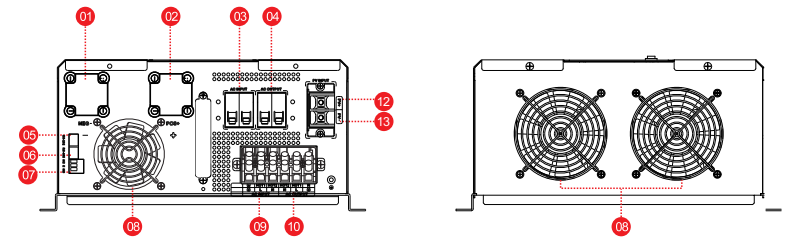

- |                                  |                              |
|----------------------------------|------------------------------|
| 1. Battery negative terminal     | 2. Battery positive terminal |
| 3. AC Input breaker              | 4. AC Output breaker         |
| 5. RS-232                        | 6. RS-485                    |
| 7. Dry contact port              | 8. Fan                       |
| 9. AC Input terminal             | 10. AC Output terminal       |
| 11. Parallel connection terminal | 12. PV positive terminal     |
| 13. PV negative terminal         | 14. Current Sharing terminal |

Connection diagram

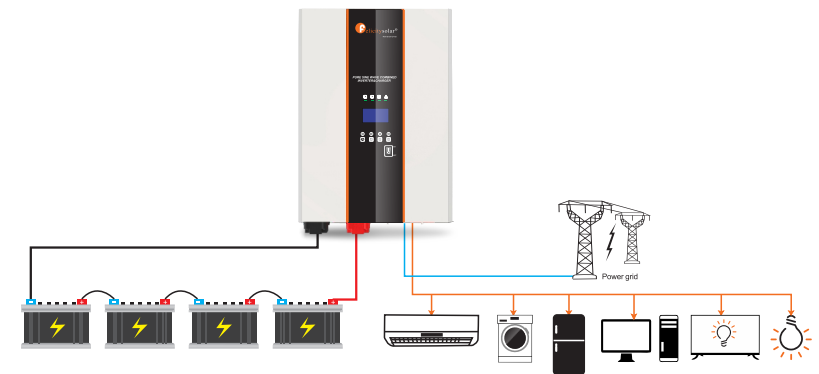

Wiring Diagram

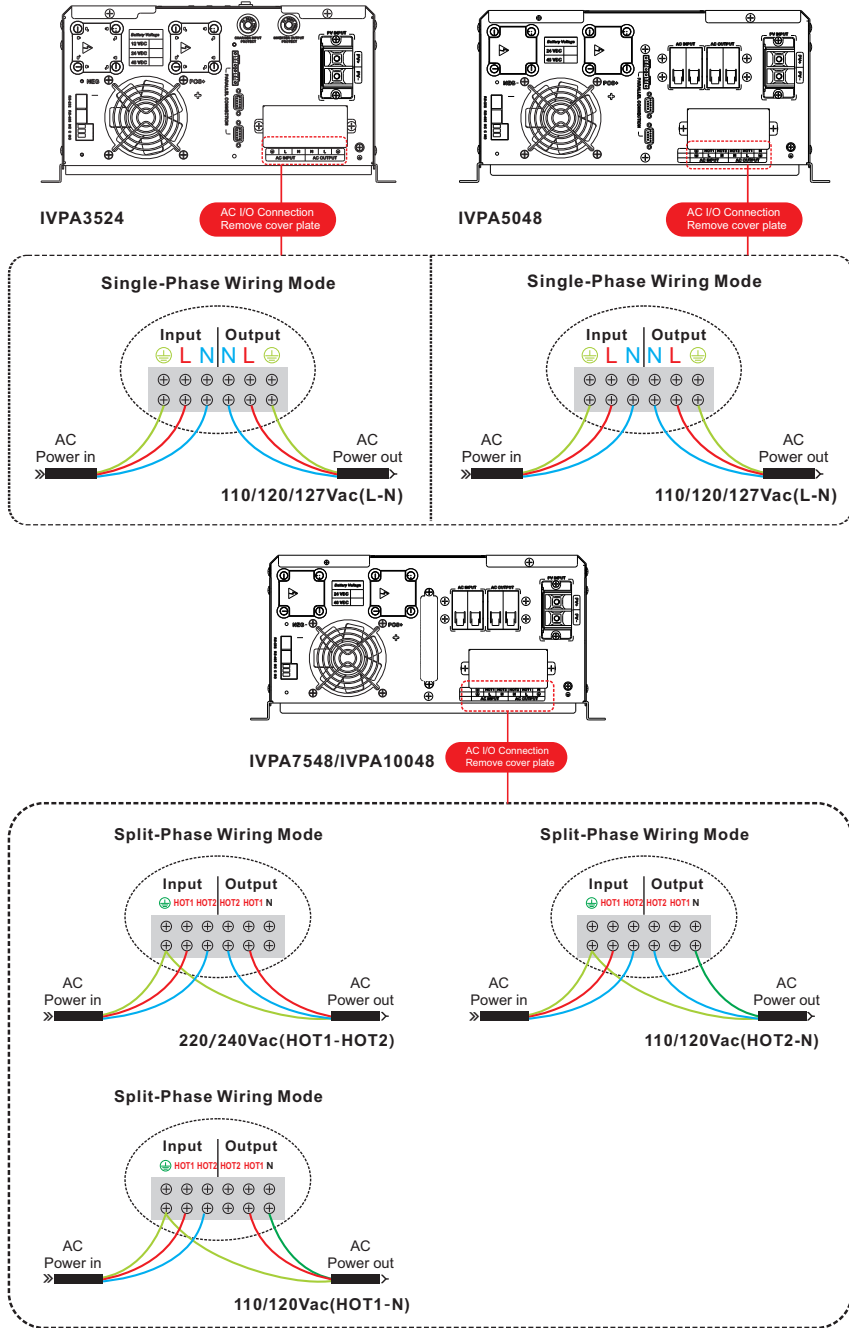

Wiring System for Inverter

Split phase connection diagram for single unit. (Only valid for 7548/10048 models)

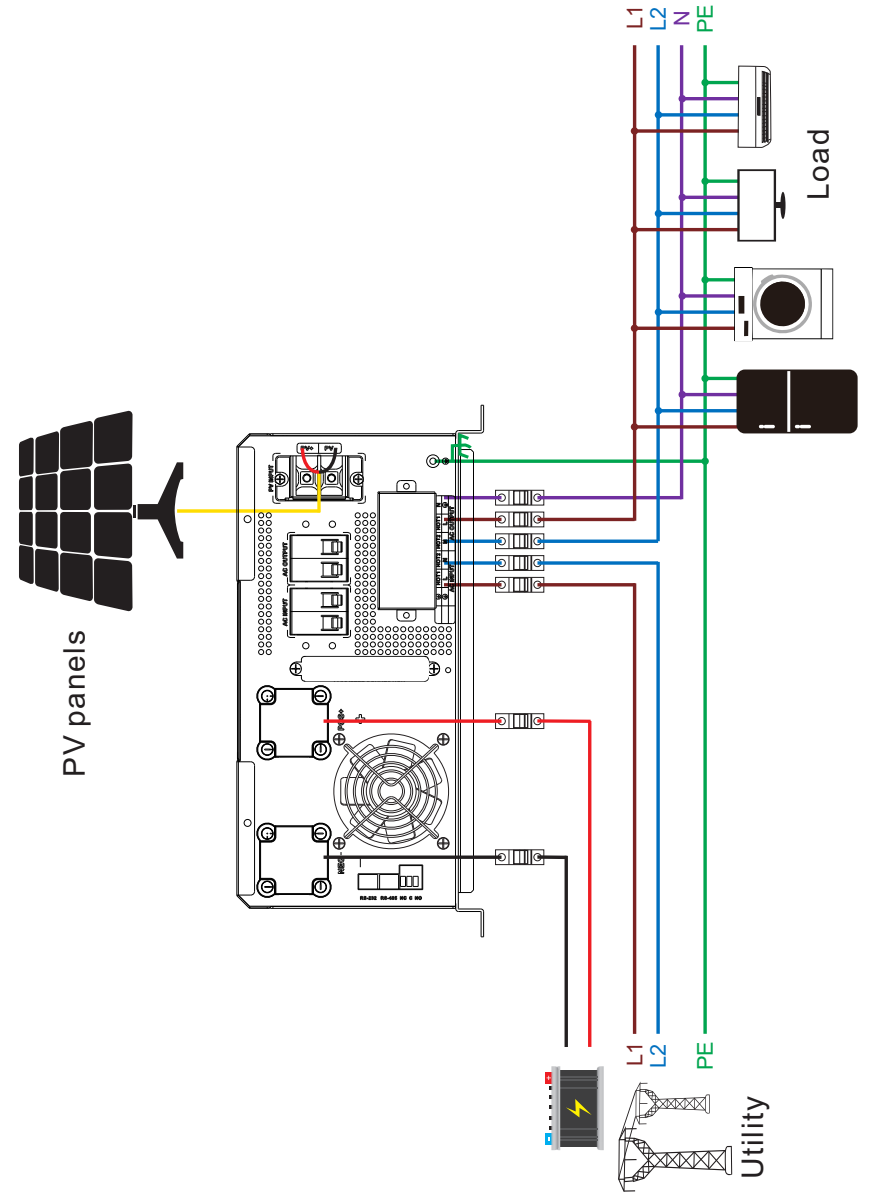

Single phase connection diagram for single unit. (Only valid for 3524/5048 models)

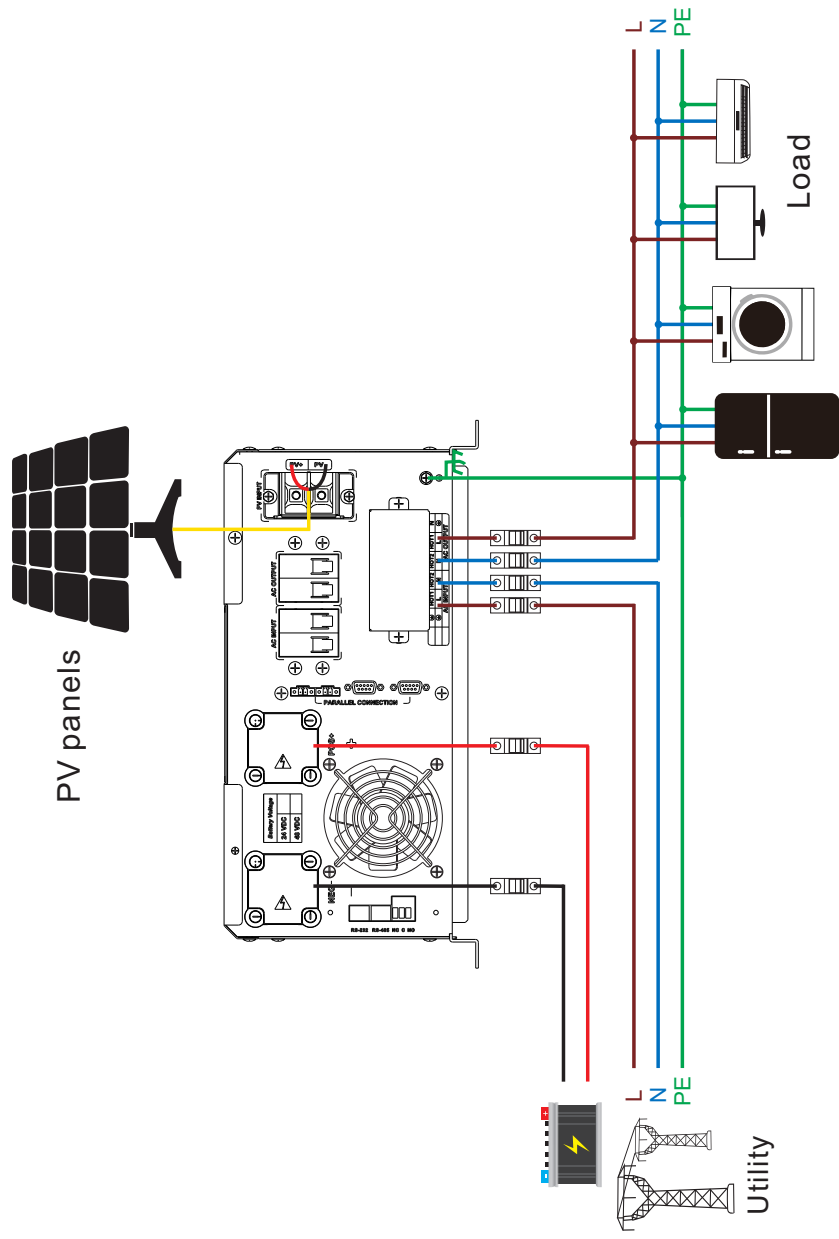

Split Phase Parallel connection diagram for two inverters in parallel. (Only valid for 3524 /5048 models)

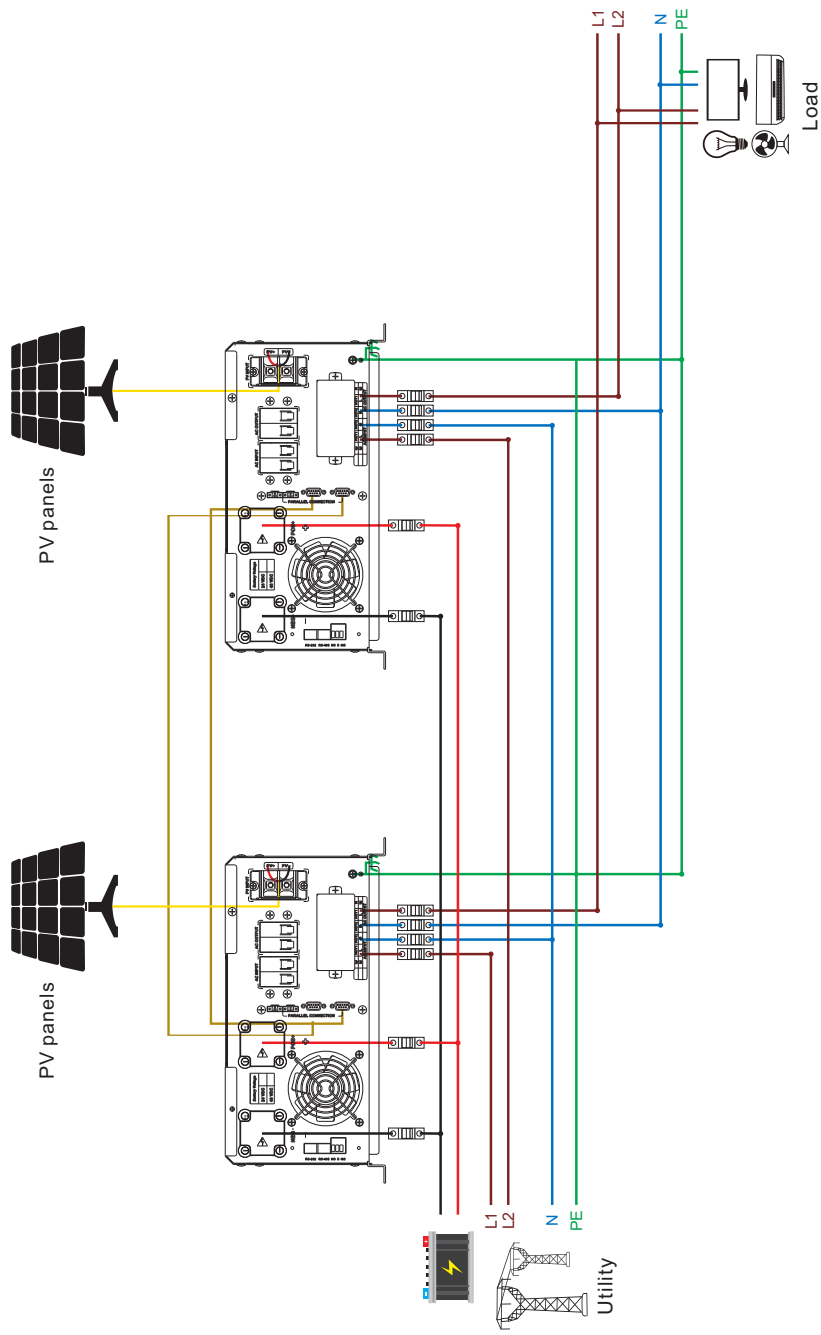

**Single Phase Parallel connection diagram for three inverters in parallel**  
(Only valid for 5048 model)

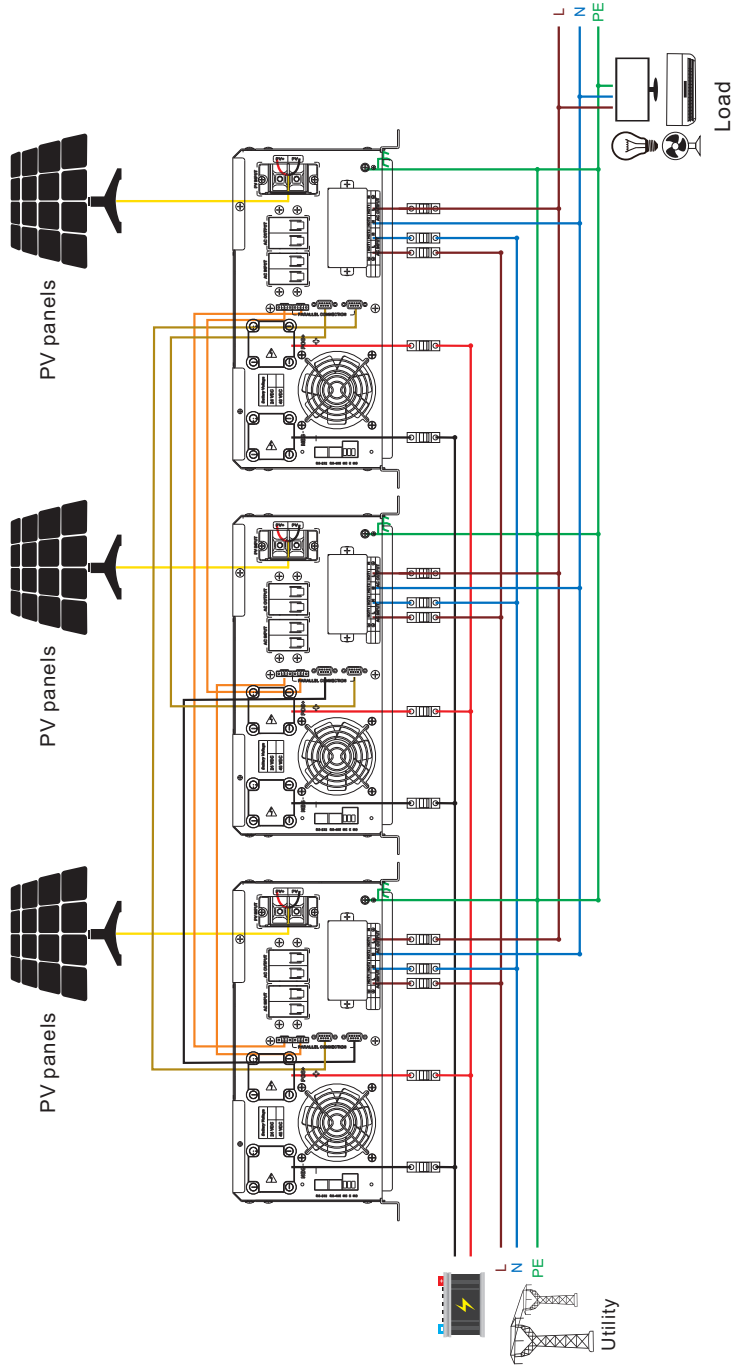



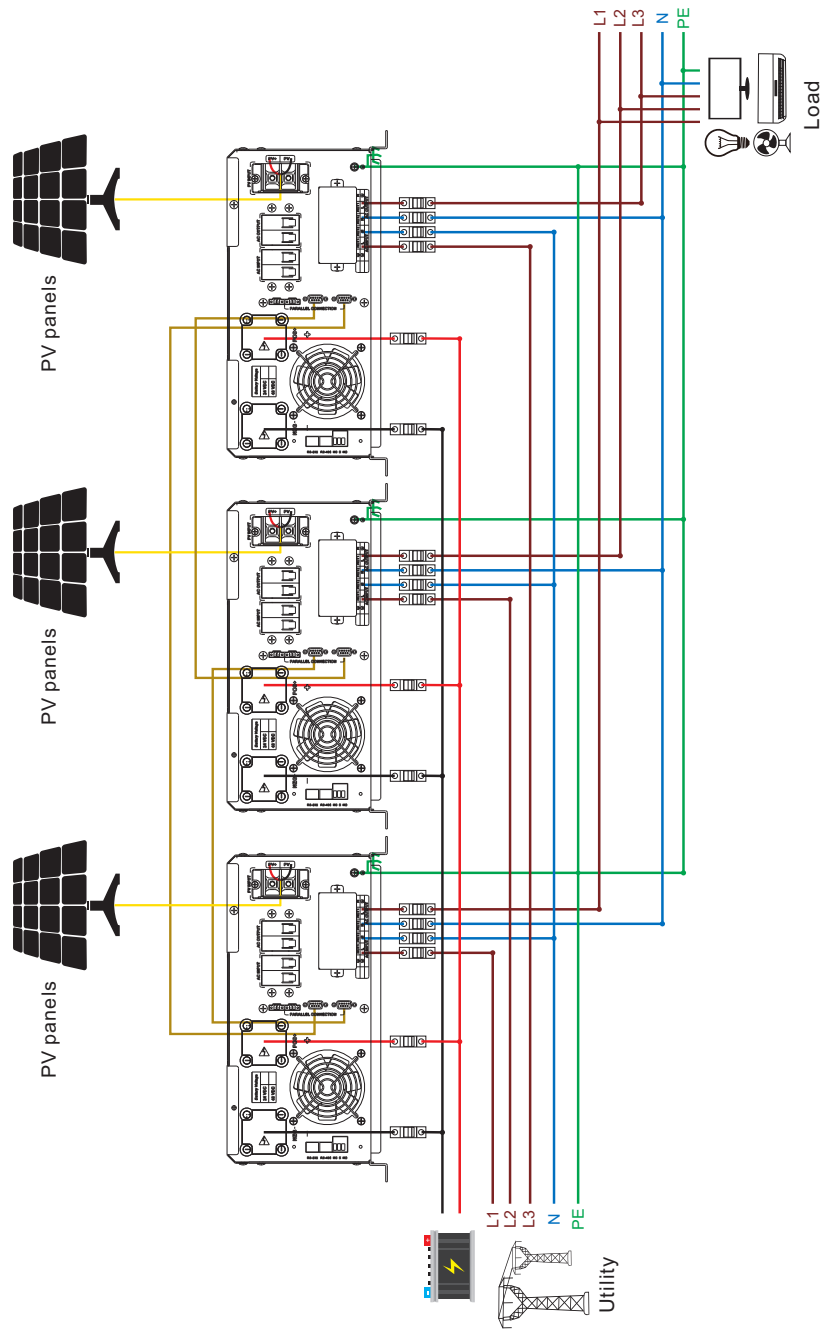



**Three Phase Parallel connection diagram for three inverters in parallel.**  
(Only valid for 5048 models)



## Parallel LCD Setting

### Setting items

Program	Description	Selectable option
28	AC output mode *This setting is only available when the inverter is in standby mode (Switch off).	 <p>When the units are used in parallel with single phase, please select "PAL" in program 28.</p>
		 <p>It is required to have at least three inverters or maximum nine inverters to support three-phase equipment. It's required to have at least one inverter in each phase or it's up to seven inverters in one phase.</p>
		 <p>Please select "3P1" in program 28 for the inverters connected to L1 phase, "3P2" in program 28 for the inverters connected to L2 phase and "3P3" in program 28 for the inverters connected to L3 phase.</p>
		 <p>It is required to have at least two inverters or maximum eight inverters to support split-phase equipment. It's required to have at least one inverter in each phase or it's up to seven inverters in one phase.</p>
		 <p>Please select "2P1" in program 28 for the inverters connected to L1 phase and "2P2" in program 28 for the inverters connected to L2 phase.</p>
		 <p>Be sure to connect share current cable to units which are on the same phase. Do NOT connect share current cable between units on different phases. Besides, power saving function will be automatically disabled.</p>
		

## COMMISSIONING

### Parallel in single phase

Step 1: Check the following requirements before commissioning:

- Correct wire connection
- Ensure all breakers in Line wires of load side are open and each Neutral wires of each unit are connected together.

Step 2: Turn on each unit and set "PAL" in LCD setting program 28 of each unit. And then shut down all units.

NOET: It's necessary to turn off switch when setting LCD program. Otherwise, the setting can not be programmed.

Step 3: Turn on each unit.

CD display in Master unit

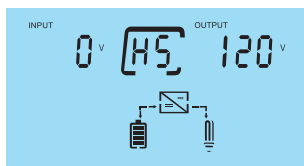

LCD display in Slave unit

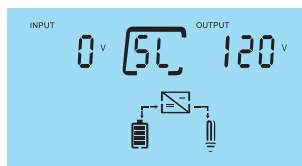

NOTE: Master and slave units are randomly defined.

Step 4: Switch on all AC breakers of Line wires in AC input. It's better to have all inverters connect to utility at the same time.

LCD display in Master unit

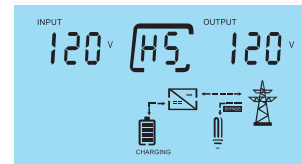

LCD display in Slave unit

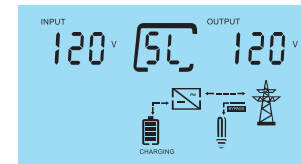

Step 5: If there is no more fault alarm, the parallel system is completely installed.

Step 6: Please switch on all breakers of Line wires in load side. This system will start to provide power to the load.

### Support split-phase equipment

Step 1: Check the following requirements before commissioning:

- Correct wire connection
- Ensure all breakers in Line wires of load side are open and each Neutral wires of each unit are connected together.

Step 2: Turn on all units and configure LCD program 28 as P1 and P2 sequentially. And then shut down all units. NOET: It's necessary to turn off switch when setting LCD program. Otherwise, the setting can not be programmed.

Step 3: Turn on all units sequentially.

LCD display in L1-phase unit

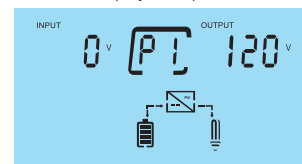

LCD display in L2-phase unit

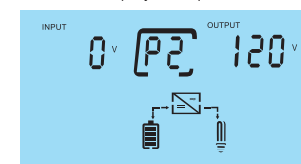

Step 4: Switch on all AC breakers of Line wires in AC input. If AC connection is detected and split phases are matched with unit setting, they will work normally.

LCD display in L1-phase unit

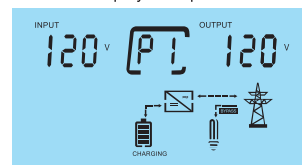

LCD display in L2-phase unit

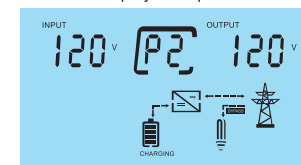

Step 5: If there is no more fault alarm, the parallel system is completely installed.

Step 6: Please switch on all breakers of Line wires in load side. This system will start to provide power to the load.

### Support three-phase equipment

Step 1: Check the following requirements before commissioning:

- Correct wire connection
- Ensure all breakers in Line wires of load side are open and each Neutral wires of each unit are connected together.

Step 2: Turn on all units and configure LCD program 28 as P1, P2 and P3 sequentially. And then shut down all units. NOET: It's necessary to turn off switch when setting LCD program. Otherwise, the setting can not be programmed.

Step 3: Turn on all units sequentially.

LCD display in L1-phase unit

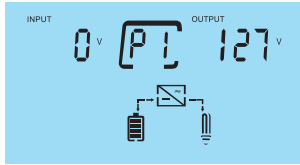

LCD display in L2-phase unit

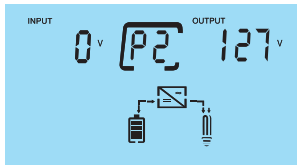

LCD display in L3-phase unit

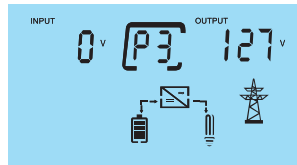

Step 4: Switch on all AC breakers of Line wires in AC input. If AC connection is detected and three phases are matched with unit setting, they will work normally.

LCD display in L1-phase unit

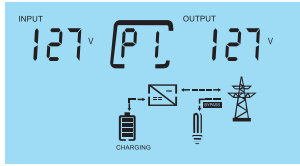

LCD display in L2-phase unit

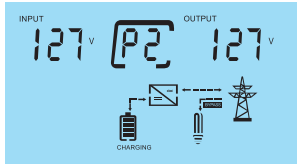

LCD display in L3-phase unit

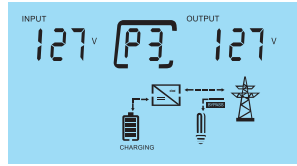

Step 5: If there is no more fault alarm, the system to support 3-phase equipment is completely installed.

Step 6: Please switch on all breakers of Line wires in load side. This system will start to provide power to the load.

Note 1: To avoid overload occurring, before turning on breakers in load side, it's better to have whole system in operation first.

Note 2: Transfer time for this operation exists. Power interruption may happen to critical devices, which cannot bear transfer time.

## Dry Contact Signal

There is one dry contact (3A/250VAC) available on the rear panel. It could be used to deliver signal to external device when battery voltage reaches warning level.

Unit Status	Condition	Dry contact port:			
		NC&C	NO&C		
Power Off	Unit is off and no output is powered.	Close	Open		
Power On	Output is powered from Battery or Solar.	Program 18 set as Utility	Battery voltage <Low DC warning voltage.	Open	Close
			Battery voltage > battery charging reaches floating stage.	Close	Open
		Program 18 is set as BAT or Solar first	Battery voltage < Setting value in Program 19.	Open	Close
			Battery voltage > Setting value in Program 20 or battery charging reaches floating stage.	Close	Open

## Specifications

Line Mode Specifications				
Model	IVPA3524	IVPA5048	IVPA7548	IVPA10048
Rated Output Power(VA)	3500VA	5000VA	7500VA	10000VA
Rated Output Power(W)	2800W	4000W	6000W	8000W
Nominal DC Input Voltage	24V	48V	48V	48V
Input Voltage Waveform	Sinusoidal (Utility or generator)			
Terminal connection	L-N		HOT1-HOT2	
Nominal Input Voltage	120Vac		220Vac	
Low Line Disconnect	90±3Vac(UPS) 80±3Vac(APL)		170±7Vac(UPS) 90±7Vac(APL)	
Low Line Re-connect AC Input Range	95±3Vac(UPS) 85±3Vac(APL)		180±7Vac(UPS) 100±7Vac(APL)	
High Line Disconnect	140±3Vac		280±7Vac	
High Line Re-connect	135±3Vac		270±7Vac	
Max AC Input Voltage	140Vrms		280Vrms	
Nominal Input Frequency	50Hz/60Hz			
Low Line Frequency Disconnect	40±1Hz			
Low Line Frequency Re-connect	42±1Hz			
High Line Frequency Disconnect	65±1Hz			
High Line Frequency Re-connect	63±1Hz			
Output Voltage Waveform	Synchronize with input voltage			
Over-Load Protection(SMPS load)	Overcurrent protector	Air switch protection	Overcurrent protector	Air switch protection
Output Short Circuit Protection	Overcurrent protector	Air switch protection	Overcurrent protector	Air switch protection
Efficiency(Line mode)	≥95%			
Transfer Time (AC to DC)	15ms (typical value)			
Transfer Time (DC to AC)	15ms (typical value)/30ms (special value)			
Pass Through Without Battery	NO			
Overcurrent Protector (grid)	50A	63A	63A	63A
Utility Charge Mode Specifications				
Input Voltage Range	80-140Vac		90-280Vac	
Nominal Output Voltage	Depends On The Battery Type			
Max Charge Current	40A	50A	60A	80A
Charge Current Regulation	0-40A	0-50A	0-60A	0-80A
Battery Initial Voltage	Circuit breaker			
Charger Short Circuit	50A	63A	63A	63A
Breaker Size	Dependent on battery type or Self-defined			
Over Charge Protection	YES			
Solar Charging & Utility Charging(MPPT built-in controller is optional)				
Max PV Open Circuit Voltage	145Vdc	195Vdc	195Vdc	195Vdc
PV Voltage Working Range	30~145Vdc	60~195Vdc	60~195Vdc	60~195Vdc
Max Input Power	2200W	6600W	6600W	6600W
Max Solar Charging Current	80A	120A	120A	120A
Max Charging current(Utility + Solar)	120A	170A	180A	200A



Charge Algorithm				
Charging way	Three phases: Boost CC (constant current level) → boost CV (constant voltage level) →Float (constant pressure level)			
Charge Stage Transition Definitions	<p>(1)Boost CC Stage: If A/C input is applied, the charger will run at full current in CC mode until the charger reaches the boost voltage.</p> <p>(2)Boost CV Stage: the charger will keep the boost voltage in Boost CV mode until the T1 timer has run out. Then drop the voltage down to the float voltage, when the charging current is lower than 20% setting value.</p> <p>(3)Float Stage: In float mode, the voltage will stay at the float voltage. If the A/C is reconnected or the battery voltage drops below 24Vdc/48Vdc, the charger will reset the cycle above.</p>			
Battery Type Setting	Battery Type	Boost CC, CV		Float
		24/48		24/48
	AGM	28.8/57.6		27.2/54.4
	Flooded	29.2/58.4		27.6/55.2
	Self Defined	Adjustable, up to 31.5/61.0		
Inverter Mode Specifications				
Model	IVPA3524	IVPA5048	IVPA7548	IVPA10048
Output Voltage Waveform	pure sine wave			
Nominal Output Voltage	110/120/127Vac±5%(L-N)		220/240Vac±5%(HOT1-HOT2)	
Split-Phase Output Voltage	/		110/120Vac±5%(HOT1-N OR HOT2-N)	
Nominal Output Frequency(Hz)	50±0.3Hz/60±0.3Hz(adjustable)			
Output Voltage Regulation	±5%rms			
Peak Efficiency	90%			
Over-Load Protection (SMPS load)	5s @ ≥150% load; 10s @ 105%-150% load			
Surge rating	2 times rated overload power 5S			
Capable of Starting Electric	YES			
Output Short Circuit Protection	YES			
Nominal DC Input Voltage	24V		48V	
Min DC Starting Voltage	23V		46V	
Battery Low Voltage Alarm	23Vdc@ load < 50% 22Vdc@ load ≥ 50%	46Vdc@ load < 50%; 44Vdc@ load ≥ 50%;		
Battery Low Voltage Re-connection	23.5Vdc@ load < 50% 23Vdc@ load ≥ 50%	47Vdc@ load < 50%; 46Vdc@ load ≥ 50%;		
Dc Low Voltage Disconnection	21.5Vdc@ load < 50% 21Vdc@ load ≥ 50%	43Vdc@ load < 50%; 42Vdc@ load ≥ 50%;		
High DC Input Alarm & Fault	31.5Vdc±0.4V		63Vdc±0.4V	
High DC Input Recovery	31Vdc±0.4V		62Vdc±0.4V	
General Specifications				
Operating temperature	0°C~40°C			
Storage temperature	-15°C~60°C			
Net Weight(KG)	30.4KG	30KG	38.1KG	55.9KG
Gross Weight(KG)	33.5KG	32.8KG	41.6KG	67.2KG
Product Dimension(MM)	440x391x195mm		580x420x195mm	
Package Dimension(MM)	552x408x290mm		607x540x290mm	
			690x480x335mm	

## Front Panel

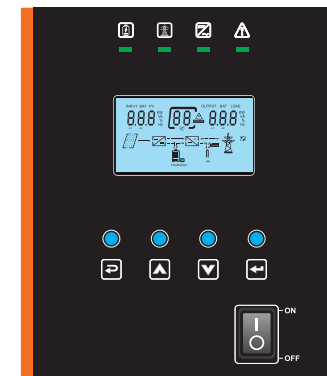

Function Key	Description
ESC	To exit setting mode
UP	To go to previous selection
DOWN	To go to next selection
ENTER	To confirm the selection in setting mode or enter setting mode
Indicator light instruction	
<b>LCD backlight</b>	Setting the control of LCD backlight enable, LCD backlight will always-on. Setting the control of LCD backlight disable, have no operation the LCD backlight will go out after 60s.
<b>Fault LED light</b>	If inverter in fault event, the red light will always-on. If inverter in warning event, the red light will flash. Inverter work normally, red light go out.
<b>Battery LED light</b>	Charging the battery, the battery light flash. If battery is full, battery light will always-on. The battery is not charged, the battery light will go out.
<b>City electricity LED light</b>	City electricity is normal, the LINE light will always-on. No city electricity, the LINE light will go out.
<b>Inverter LED light</b>	Battery discharging, inverter light will always-on. Battery not discharging, inverter light will go out.
<b>Buzzer beep</b>	Turn on/off the inverter, the buzzer will last for 2.5s. Press any button, the buzzer will last for 0.1s. Hold on the ENTER button, the buzzer will last for 3s. If in fault event, the buzzer will keep going. If in warning event, the buzzer will beep discontinuous.

## LCD Setting

After pressing and holding "ENTER" button for 3 seconds, the unit will enter setting mode. Press "UP" or "DOWN" button to select setting programs. And then, press "ENTER" button to confirm the selection or ESC button to exit.

## Setting items

Program	Description	Selectable option
00	Exit setting	00 ESC
01	Output voltage setting*This setting is only available when the inverter is in standby mode (Switch off).	Output voltage 110V OPV 01 110V
		output voltage 120V (default) OPV 01 120V
		Output voltage 127V OPV 01 127V
		output voltage 220V (default) OPV 01 220V
		Output voltage 240V OPV 01 240V
		Output voltage configuration (Only for IVPA3524/IVPA5048)
02	Output frequency setting	output frequency is 50Hz OPF 02 50Hz
		60Hz(default) OPF 02 60Hz
		Output frequency configuration
03	Utility input range setting	Appliance mode(default) AC 03 APL
		UPS mode AC 03 UPS
		APL should be selected, when the utility is not well.

05	Battery type setting	The battery type is self-define(default) bAt 05 USE	If "Self-defined" is selected, battery charge voltage and low DC cut-off voltage can be set up in program 07, 08 and 11.
		The battery type is Flooded bAt 05 FLd	
		The battery type is AGM bAt 05 AGn	
		The battery type is Llb bAt 05 Llb	
06	Max utility charging current setting	20A (default) CHC 06 20 A	3500VA: Setting range is from 0 to 40A 5000VA: Setting range is from 0 to 50A 7 500VA: Setting range is from 0 to 60A 10000VA: Setting range is from 0 to 80A
07	Bulk charging voltage setting (C.V voltage)	48V model(57.6V default) CV 07 57.6V	If self-defined is selected in program 05, this program is enable. Setting range is from 48.0V to 61.0V. Increment of each click is 0.1V.
		24V model(28.8V default) CV 07 28.8V	If self-defined is selected in program 05, this program is enable. Setting range is from 25.0V to 31.5V. Increment of each click is 0.1V.
08	Floating charging voltage	48V model(54.4V default) FLV 08 54.4V	If self-defined is selected in program 5, this program is enable. Setting range is from 48.0V to 61.0V. Increment of each click is 0.1V.
		24V model(27.2V default) FLV 08 27.2V	If self-defined is selected in program 5, this program is enable. Setting range is from 25.0V to 31.5V. Increment of each click is 0.1V.
09	Charger priority.	If inverter is working in utility mode, charge priority can be set as below. However, when inverter is working in Battery mode, only PV can charge battery.	
		PV first CHS 09 PV	PV will charge battery first. Utility will charge battery only when PV is unavailable.
		PV and Utility (default) CHS 09 PAU	PV and utility will charge battery together.

09	Charger priority.	PV Only CHS 09 P40	Only PV can charge the battery.
10	Max charging current (Max charging current = utility charging current + PV charging current)	60A (default) bCC 10 60 A	3500VA: Setting range is from 0 to 120A 5000VA: Setting range is from 0 to 170A 7500VA: Setting range is from 0 to 180A 10000VA: Setting range is from 0 to 200A
11	Low DC cut-off voltage	48V model(42V default) bCY 11 42.0 V	If self-defined is selected in program 5, this program is enable. Setting range is from 42.0V to 52.0V. Increment of each click is 0.1V.
		24V model(21V default) bCY 11 21.0 V	If self-defined is selected in program 5, this program is enable. Setting range is from 21.0V to 26.0V. Increment of each click is 0.1V.
12	Overload bypass function	Disable (default) LbP 12 ENA	If it is enabled, the inverter will switch to utility mode if overload happens in battery mode.
		LbP 12 DIS	
15	Buzzer Alarm	Enable (default) bEP 15 ENA	
		bEP 15 DIS	
16	BMS communication setup	external communication(default) bnS 16 nnt	external communication Baud rate 2400 bit/s.
		BMS communication bnS 16 bnS	BMS communication, Baud rate 9600 bit/s.
17	Back light of LCD	Enable (default) bL 17 ENA	Setting the control of LCD backlight enable, LCD backlight will always-on. Setting the control of LCD backlight disable, have no operation the LCD backlight will go out after 60s.
		bL 17 DIS	

18	Output source priority	Utility first (default) OPS 18 UTI	Utility will provide power to the loads first, battery will provide power to the loads only when utility power is not available.
18	Output source priority	PV first OPS 18 PV	PV provides power to the loads first. If PV energy is not sufficient, battery will feed power to the loads. Utility provides power to the loads only when any one condition happens: (1) PV is unavailable; (2) Battery voltage drops to low-level warning voltage or the setting point in program 19.
		Battery first OPS 18 BAT	battery provides power to the loads first, utility provides power to the loads only when battery voltage drops to either low-level warning voltage or the setting point in program 19. And when battery voltage return to the setting point in program 20, the inverter will switch to battery mode;
19	Setting battery voltage point back to utility when selecting "BAT priority" in program 18.	48V model(default 46.0V) bUV 19 46.0 V	Setting range is from 44.0V to 51.0V. Increment of each click is 1V.
		24V model(default 23.0V) bUV 19 23.0 V	Setting range is from 22.0V to 25.5V. Increment of each click is 0.5V.
20	Setting battery voltage point back to battery mode when selecting "BAT priority" in program 18.	48V model(default 54.0V) bbV 20 54.0 V	Setting range is from 48.0V to 58.0V. Increment of each click is 1V. "FUL" means the battery should be charged to float mode;
		24V model(default 27.0V) bbV 20 27.0 V	Setting range is from 24.0V to 29.0V. Increment of each click is 0.5V. "FUL" means the battery should be charged to float mode;
37	Power Key Mode	Output off (default) PtN 37 OOF	When power key is off and utility is charging to battery, Output is off.
		Output on PtN 37 OON	When power key is off and utility is charging to battery, Output is on.

LCD Display Icons

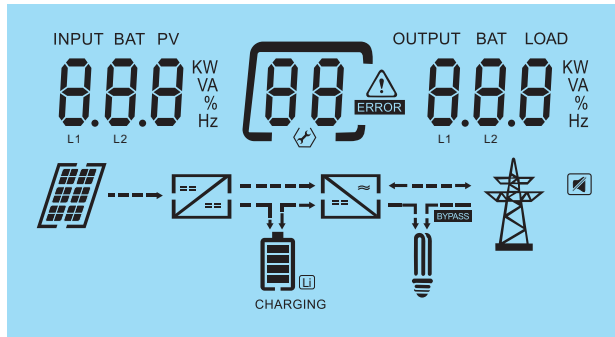

Icon	Function description
<b>Input Source Information</b>	
<b>INPUT</b>	Indicates the AC input.
	Indicate input voltage, input frequency, battery voltage, Fire L1, Fire L2.
<b>Configuration Program and Fault Information</b>	
	Indicates the setting programs.
	Indicates the warning and fault codes. Warning: flashing with warning code. Fault: lighting with fault code
<b>Output Information</b>	
	Indicate output voltage, output frequency, load percent, load in VA, load in Watt.
<b>Battery Information</b>	
	Indicates battery level by 0-24%, 25-49%, 50-74% and 75-100%. The Li icon represents a lithium battery.

In battery mode, it will present battery capacity.

Load Percentage	Battery Voltage	LCD Display
Load > 50%	< 11.1V/PCS	
	11.1~ 11.6V/PCS	
	11.6V ~ 12.1V/PCS	
	> 12.1V/PCS	
Load < 50%	< 11.3V/PCS	
	11.3 ~ 11.8V/PCS	
	11.8 ~ 12.3V/PCS	
	> 12.3V/PCS	
<b>Mode Operation Information</b>		
	Indicates the utility.	
	Indicates load is supplied by utility directly.	
	Indicates the inverter / charger is working.	
<b>Mute Operation</b>		
	The alarm is disabled.	

## Display Information

The LCD information will be switched by pressing “Up” or “Down” key. The selectable information is switched as below order: input voltage/frequency, battery voltage, charging current, output voltage/frequency, load percent, load in Watt, load in VA, load in Watt, main CPU Version.

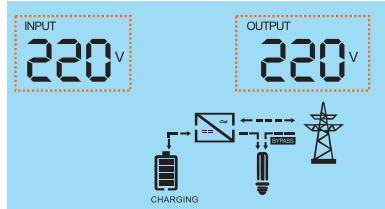

### Input voltage/Output voltage

Utility voltage is 220V, output voltage is 220V

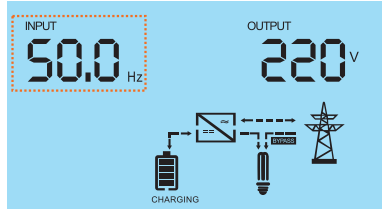

### Input frequency

Utility frequency is 50.0Hz

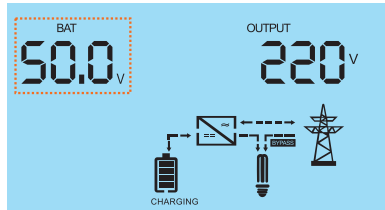

### Battery voltage

Battery voltage is 50.0V

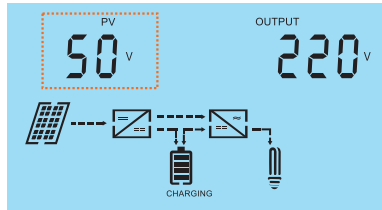

### PV voltage

PV voltage is 50V  
(for PWM / MPPT Charge Controller)

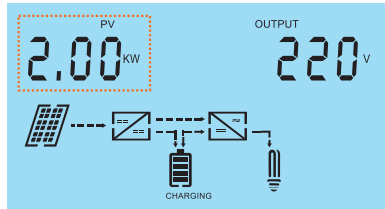

### PV power

PV power is 2KW  
(for PWM / MPPT Charge Controller)

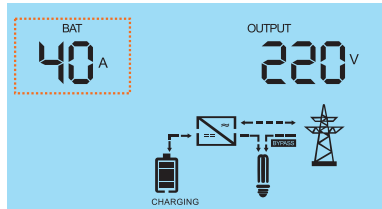

### Charging current

Charging current is 40A

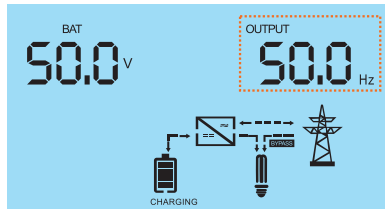

### Output frequency

Output frequency is 50Hz

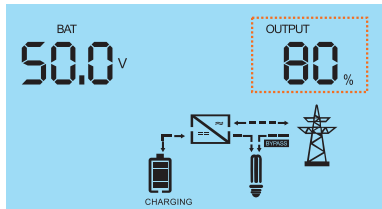

### Load percentage

Load percent is 80%

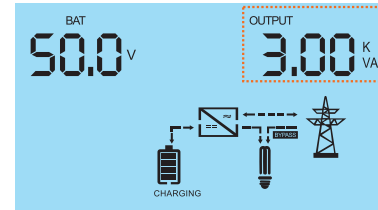

### Load in VA

The load is 3.0KVA

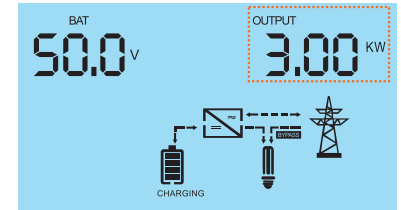

### Load in Watt

The load is 3.0KW.

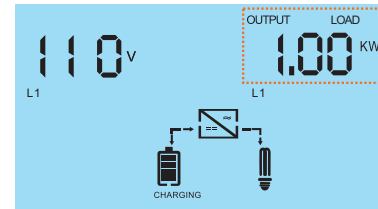

### L1 power

L1 power is 1.0KW

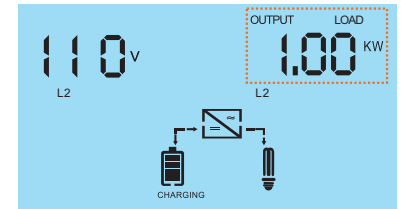

### L2 power

L2 power is 1.0KW

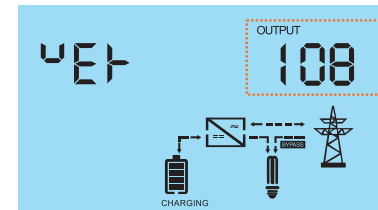

### CPU software version

CPU software version 108

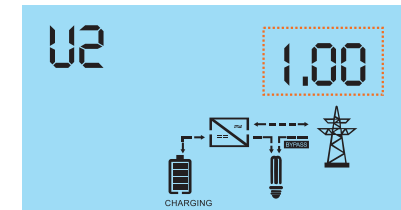









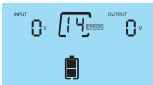



### MPPT Charge Controller software version



CPU software version 1.00  
MPPT Charge Controller software version  
( for MPPT Charge Controller Build-in )

### Fault Code Table

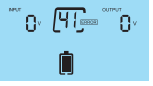
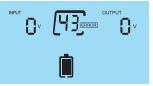
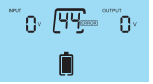
When fault event happens, inverter will cut off output, and the red LED is solid on. At the same time, fault code is shown on the LCD screen.



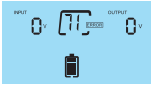







Fault Code	Fault information	Trouble Shooting
13	Overload happens	<p>Not allowed to overload when the inverter in battery mode, If overload, please turn off the inverter first, and then decrease the load let the load power less than the rated output power of invert, turn on the inverter again.</p> <p>If overload and the AC input is on, wait for 30s and it will clear away the fault automatically and work normally.</p> 
14	Output voltage high	<p>Restart the inverter or Contact our engineer.</p> 
15	Output short	<p>If AC input is on, must cut off the AC input first and then turn off the inverter, disconnect all AC output wiring and turn on it. If the screen still display fault, please connect our engineer. And if the inverter can work again, please check the output wiring and load, make sure all of them not shorted connection.</p> 
17	Battery voltage high	<p>Read the battery voltage from the screen, and measure the voltage of battery with multimeter . if both of the voltage are more than 60v, maybe the battery have some problem we must stop using it.</p> 
18	Over temperature	<p>Turn off the inverter, let it cool down, after the temperature back to normal and you can use it again.</p> 
21	Over current happen in charging mode	<p>Please contact our engineer.</p> 
22	Inv soft start timeout	<p>Please contact our engineer.</p> 
24	Output voltage low	<p>Turn off the inverter, disconnect all AC output wiring and then turn on it, if it still fault please contact our engineer, if it work normally, please check the output whether connect a big power load, disconnect the big one and turn on the inverter, confirm it can work normally.</p> 
27	Battery disconnected	<p>Please check the battery connector</p> 

28	Current sensor is abnormal	Please contact our engineer.	
32	INV NTC is Disconnected is abnormal	Please contact our engineer.	
34	Heavy over load or output short	Please refer to Fault 13 and15 handling.	
40	CAN data loss	<ol style="list-style-type: none"> <li>1. Check if communication cables are connected well and restart the inverter.</li> <li>2. If the problem remains, please contact your installer.</li> </ol>	
41	Host data loss		
42	Synchronization data loss		
43	The battery voltage of each inverter is not the same.	<ol style="list-style-type: none"> <li>1. Make sure all inverters share same groups of batteries together.</li> <li>2. Remove all loads and disconnect AC input and PV input. Then, check battery voltage of all inverters. If the values from all inverters are close, please check if all battery cables are the same length and same material type. Otherwise, please contact your installer to provide SOP to calibrate battery voltage of each inverter.</li> <li>3. If the problem still remains, please contact your installer.</li> </ol>	
44	AC input voltage and frequency are detected different.	<ol style="list-style-type: none"> <li>1. Check the utility wiring connection and restart the inverter.</li> <li>2. Make sure utility starts up at same time. If there are breakers installed between utility and inverters, please be sure all breakers can be turned on AC input at same time.</li> <li>3. If the problem remains, please contact your installer</li> </ol>	
45	AC output current unbalance	<ol style="list-style-type: none"> <li>1. Restart the inverter.</li> <li>2. Remove some excessive loads and re-check load information from LCD of inverters. If the values are different, please check if AC input and output cables are in the same length and material type.</li> <li>3. If the problem remains, please contact your installer.</li> </ol>	
46	AC output mode setting is different.	<ol style="list-style-type: none"> <li>1. Switch off the inverter and check LCD setting #28.</li> <li>2. For parallel system in single phase, make sure no 3P1, 3P2, 3P3, 2P1 or 2P2 is set on #28. For supporting three-phase system, make sure no "PAL", 2P1 or 2P2 is set on #28. For supporting split-phase system, make sure no "PAL" , 3P1 , 3P2 or 3P3 is set on #28.</li> <li>3. If the problem remains, please contact your installer.</li> </ol>	

60	Current feedback into the inverter is detected.	<ol style="list-style-type: none"> <li>Restart the inverter.</li> <li>Check if LN cables are not connected reversely in all inverters.</li> <li>For parallel system in single phase, make sure the sharing are connected in all inverters. For supporting three phase system or split phase system, make sure the sharing cables are connected in the inverters in the same phase, and disconnected in the inverters in different phases.</li> <li>If the problem remains, please contact your installer.</li> </ol>	
71	The firmware version of each inverter is not the same.	<ol style="list-style-type: none"> <li>Update all inverter firmware to the same version</li> <li>Check the version of each inverter via LCD setting and make sure the CPU versions are same. If not, please contact your installer to provide the firmware to update.</li> <li>After updating, if the problem still remains, please contact your installer.</li> </ol>	
72	The output current of each inverter is different.	<ol style="list-style-type: none"> <li>Check if sharing cables are connected well and restart the inverter.</li> <li>If the problem remains, please contact your installer.</li> </ol>	

## Warning Code Table

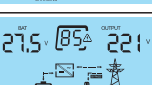
When warning event happens, the red LED is flashing. At the same time, the warning code is flashing on the LCD screen.

Warning Code	Warning information	Trouble Shooting	
01	Overload happens	The inverter forbid to over-load, the last working time will depend on the percent of load.	
04	Battery low	The voltage of battery is too low, the battery should be charging.	
05	Power derating (low utility voltage)	Read the voltage from the screen and confirm the voltage of AC input is about 90-170v. If it is ,means the voltage of AC input is low, it can work normally. If not, please contact our engineer.	
06	TX NTC is disconnected	Please contact our engineer.	
07	INV NTC is disconnected	Please contact our engineer.	
14	Input Phsae Abnormal	Please contact our engineer.	
/	Flash	City electricity is not match to the inverter	
83		Faults for over charging current of built in MPPT	
84		Faults for battery low voltage of built in MPPT	
85		Faults for battery high voltage of built in MPPT	
87		Faults for high temperature of built in MPPT	
88		Faults for pv over voltage of built in MPPT	

## MPPT charger controller match to the Inverter

In actually application system, MPPT controller and inverter will charge the battery at the same time, the charging current will excessive to occur unsafe situation, so we add the function of match the inverter and the MPPT controller to protect the battery more better, and more scientific to management the charging from solar panel or utility source.

**NOTE:** The inverter and MPPT controller are both just from our company can be matched and the maximum continuous charging current should be no more than 30% of the battery capacity. For example for the 48V200AH battery pack ,the continuous charging current should be less than 60A.

### The inverter match to the MPPT controller have 2 main function

- 1.Enable or disable inverter to match MPPT function.(Special note: when the inverter upgrades the firmware, it needs to disable the function matching MPPT first)
- 2.Limited the the inverter charging current, the method as follow: A) When the MPPT charging current  $\geq$  the current limited by the inverter ,and then the inverter maximum charging current is 0.B)When the MPPT charging current  $<$  the current limited by the inverter, the inverter maximum charging current =the total charging current set by the inverter -MPPT charging current.

### Match the inveter to the MPPT controller:

1. To enable the inverter to match the MPPT controller, the inverter and MPPT controller should be switched on first, and the communication lines between them have been connected;
2. Then press the "Down" button of the inverter for more than 2.5 seconds, until the MPPT charger icon flashes. Release the button,. The icon flash indicates that the inverter is trying to communicate with MPPT.The icon of the inverter stops flashing 10 seconds after the button is released, and when the communication is successful, it means that it has been enabled successfully.
3. Once enabled successfully, matching MPPT function flag will be saved in EEPROM, and restart the inverter needn't to manually enable again.
4. After successful enabling, the pv-voltage, power and other information of MPPT will be displayed when page-turning on the LCD screen.

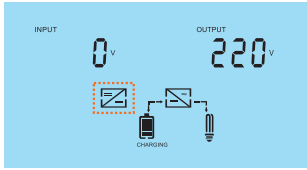
Action	Instruction	LCD display
Match the MPPT function enable	Long press "Down" button until the icon in the red box in the right picture flashes, indicating that the inverter is trying to communicate with MPPT. The icon stops flashing after the inverter loosens the button for 10 seconds	

### Matching MPPT function is prohibited:

1. To prevent the inverter from matching the MPPT function, the MPPT should be turned off or the communication connection between the two should be disconnected.
2. Then long press the "Down" button of the inverter for more than 2.5 seconds, until the MPPT charger icon flashes. At this point, the button can be released. The flashing icon indicates that the inverter is trying to communicate with MPPT. The flashing icon will stop 10 seconds after the button is released. Failure to communicate indicates a successful prohibition.
3. After successful prohibition, matching the MPPT function flag will be saved in EEPROM. Restart the inverter without manual prohibition again.
4. After successful prohibition, pv-voltage, power and other information of MPPT will no longer be displayed on the LCD screen.

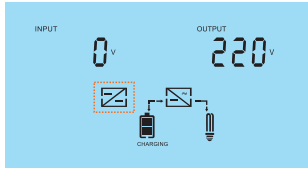
Action	Instruction	LCD display
Matching MPPT function is prohibited	Long press "Down" button until the icon in the red box in the right picture flashes, indicating that the inverter is trying to communicate with MPPT. The icon disappears after the inverter loosens the button for 10 seconds	

### Matching MPPT function successfully enabled:

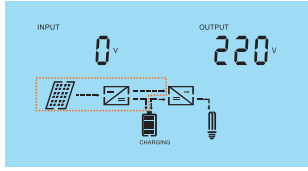
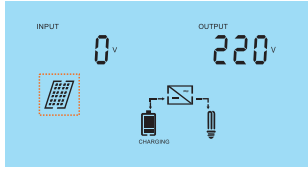
Action	Instruction	LCD display
Match MPPT function to enable successfully	If MPPT is in charging state: When the MPPT function is successfully enabled, the icon in the red box in the right picture will appear	
Match MPPT function to enable successfully	If MPPT is not in the charging state, but PV voltage is greater than 30V and is in the startup state: When the MPPT function is successfully enabled, the icon in the red box in the right picture will appear	

### Matching MPPT function is prohibited successfully:

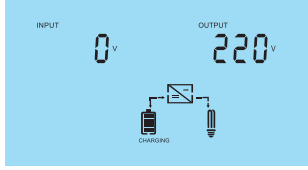
Action	Instruction	LCD display
Match MPPT function	When the matching MPPT function is prohibited successfully, MPPT icon information will no longer be displayed	
Whether matching MPPT function enables judgment	1. If the MPPT function is enabled, the LCD interface page turning will display PV voltage,power and other information; 2. If the matching MPPT function is prohibited, the LCD interface page turning will not display PV voltage, power and other information;	