

Fingerprint & Card Access Control Panel User Guide

Note: The fingerprint & card Access Control panel can connect our company fingerprint reader or normal wiegand RFID reader.

(1) If connect fingerprint reader: Dial switch A switch 1~8 to ON, and Dial switch B switch 1~8 to OFF



A

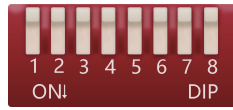

B

(2) If connect normal wiegand RFID reader: Dial switch A switch 1~8 to OFF, and Dial switch B switch 1~8 to ON



A

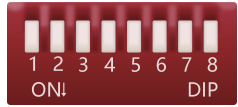

B

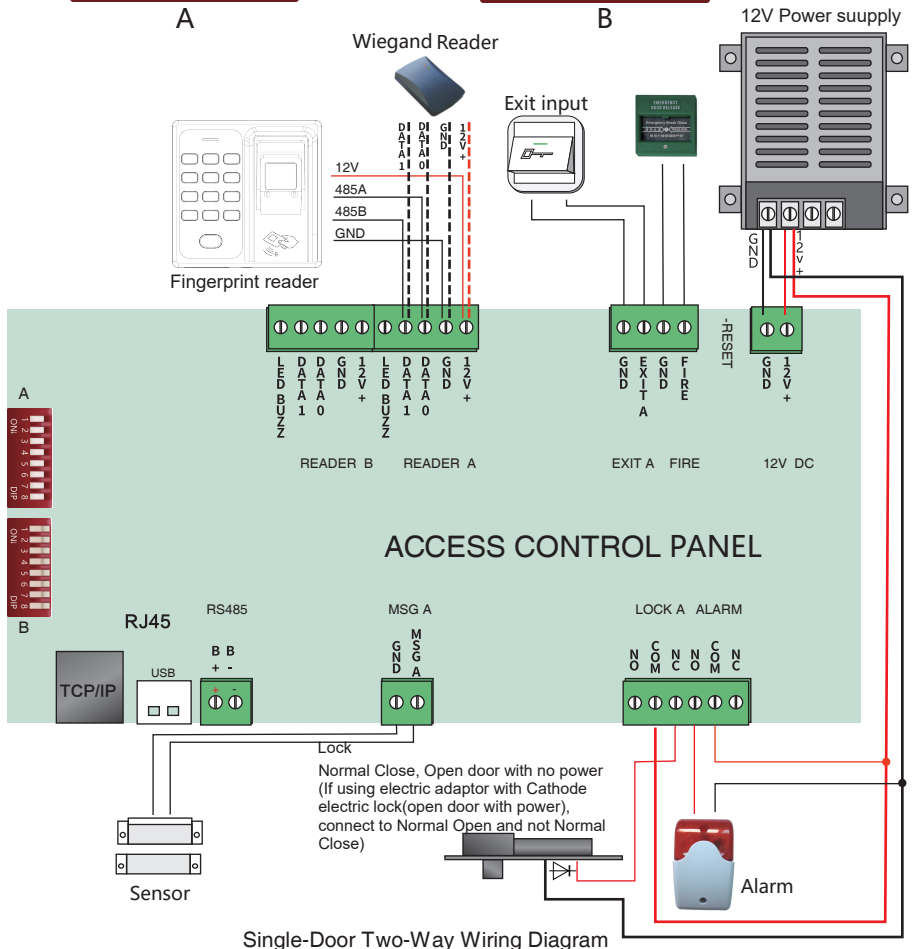

Single-Door Two-Way Wiring Diagram

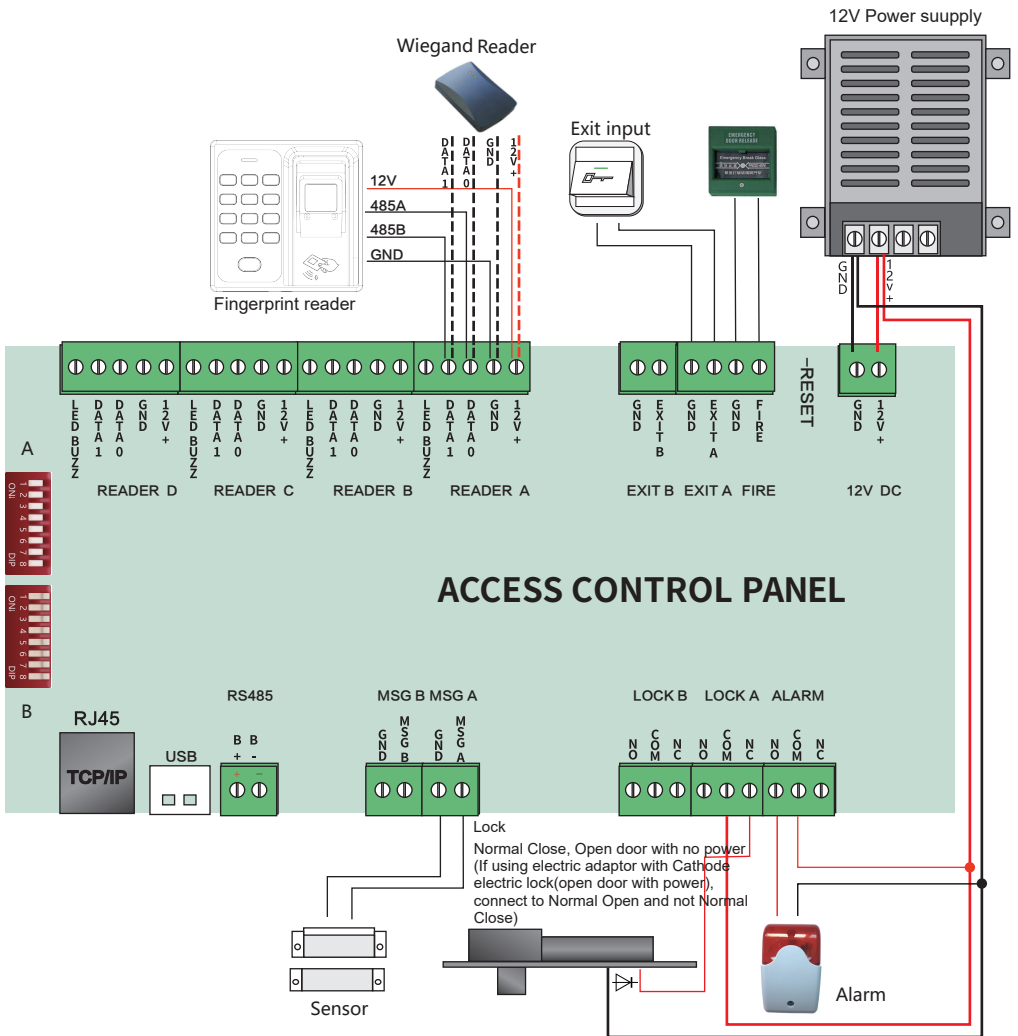

Two-Door Two-Way Wiring Diagram

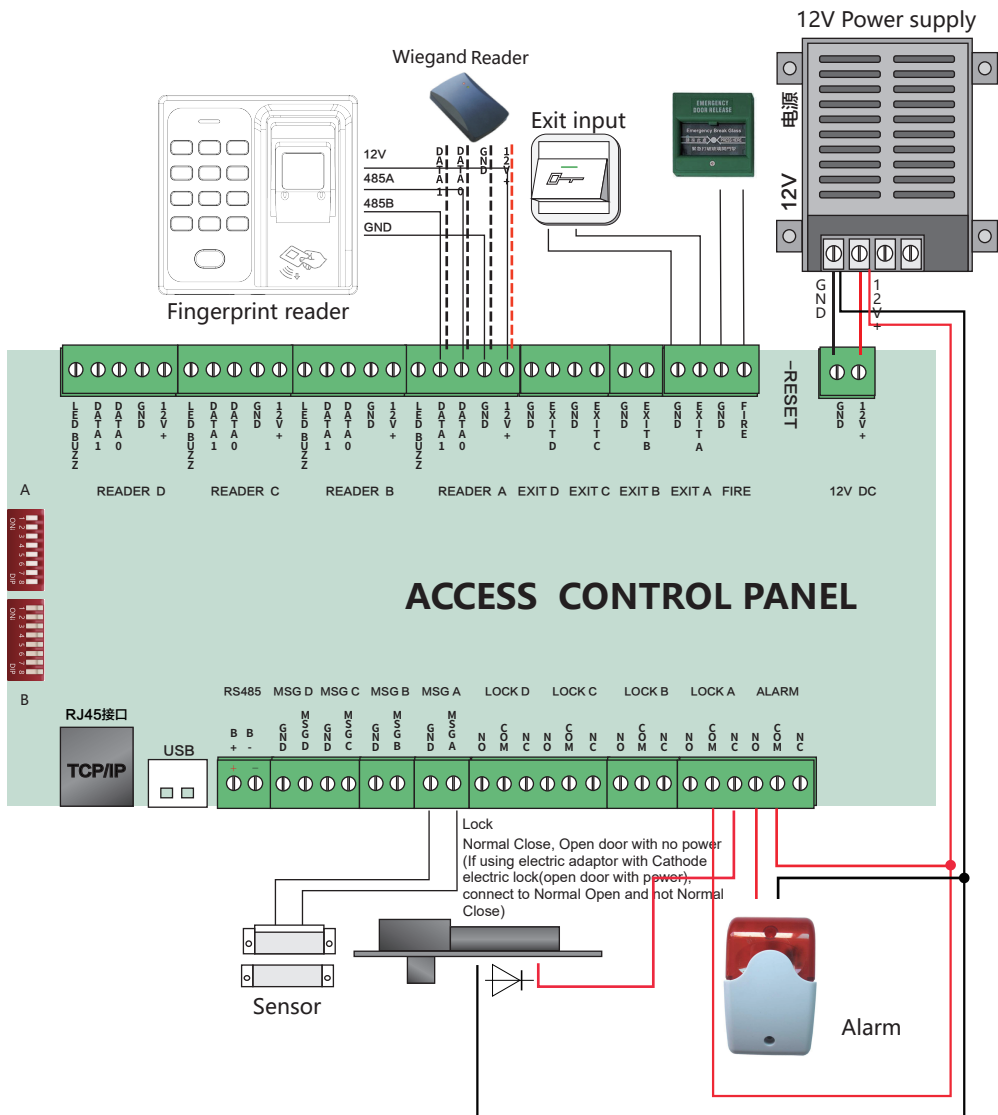

Four-Door Single-Way Wiring Diagram

User Guide



I : Fingerprint Collection

1: Connect the USB fingerprint reader into a computer with access control software installed. Run the access control software to collect fingerprint.

II : Setup of the device number, the IP address or the server IP address and the port number of the controller

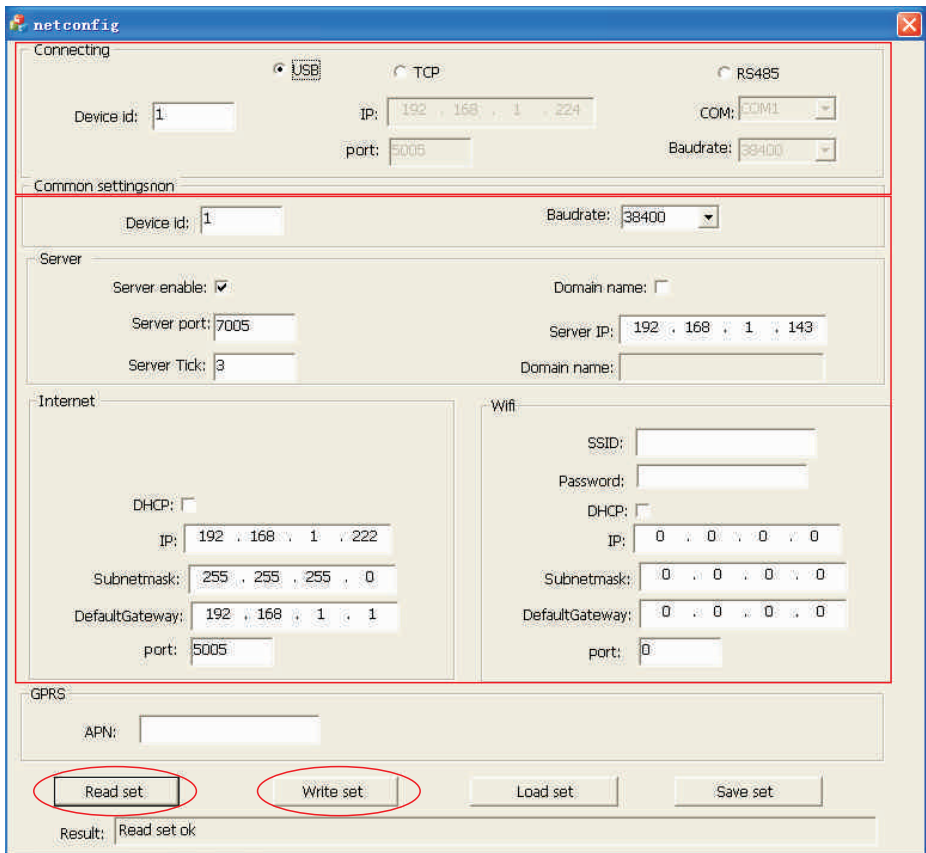
1: Run the program netconfig.exe. It is in company with the package of the controller. Then, use USB cable or TCP/IP or RS485 to connect the controller. (The default setting of the controller is device number of 1, IP address of 192.168.1.224 and port number of 5005).

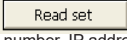

- 2: Click the button  < Read set> to get the configuration of the controller board.
- 3: Input the device number, IP address, server IP address and port number. Then click the button  <Write set>

III : Door not opened by pressing fingerprint or swiping card

- 1: Check whether the enrolled fingerprint or card have been uploaded to the controller through the Access control system? Check whether the FINGER light turning on when pressing a valid fingerprint or swiping a valid card. On the contrary, will the ERR light turning on when we press an invalid fingerprint or swipe an invalid card.
- 2: Check whether the person who press fingerprint or swipe card has rights of opening door. Besides, is this rights being uploaded to the controller.
- 3: When pressing fingerprint or swiping card, listen to the pulse sound of the relay. Besides, we could check whether the yellow light near the relay turning on. If the yellow light is on while there is no sound of pulse in the relay, please check whether the voltage is too low.

IV: TCP/IP fail to connect

- 1: Check whether the network cable is broken or the RJ45 jacket is not good. If the metal plate of RJ45 jacket could not contact the wire well, the connection will be lost.
- 2: Check whether the IP address and the device number are input correctly.

V: Restore to factory default. (It will not affect the enrolled fingerprint and card information in the controller nor the rights of opening door)

- 1: When the controller is power on, press the button <RESET>. Then, the argument in the controller will be restored to the factory default value(The factory default setting is device number of 1, IP address of 192.168.1.224 and port number of 5005. (It will not affect the enrollment fingerprint and card information in the controller nor the rights of opening door).