



# M280 MANUAL

(Also known as SN-510)

Version: 4.0.1

Model: M280-T1

M280CG-T1

M280P-T1

2024-9

# CONTECTS

1. FUNCTION OVERVIEW .....	1
2. TECHNICAL PARAMETERS .....	1
2.1. PRODUCT INFORMATION .....	1
2.2. COMPONENT .....	2
2.3. INDICATOR STATUS .....	2
2.4. MODEL AND FUNCTION DESCRIPTION .....	3
3. APPLICATION SOLUTION .....	3
3.1. SN-510 DISENGAGES OUT OF CLOUD CONTROL .....	3
3.1.1. WORKING WITH A SINGLE SN DEVICE .....	3
3.1.2. MULTIPLE SN DEVICES WORK SYNCHRONOUSLY .....	4
3.2. SN-510 DISENGAGES FROM CLOUD CONTROL .....	5
3.2.1. A SINGLE SN DEVICE WORKED BY THE CLOUD PLATFORM .....	5
3.2.2. MULTIPLE SN DEVICES WORKED BY THE CLOUD PLATFORM .....	6
3.3. EXTERNAL CONTROL CABLE DIAGRAM .....	7
3.3.1. DMX CONNECTION .....	7
3.3.2. OTHER EXTERNAL CONTROL DEVICES .....	8
3.4. EXTENSION .....	8
3.4.1. OPTICAL FIBER COMMUNICATION .....	8
3.4.2. 4G SIGNAL NETWORKING .....	9
3.4.3. SYNCHRONOUS ANTENNA .....	9
4. BASIC OPERATION .....	9
4.1. INTERFACE INTRODUCTION .....	9
4.2. UNLOCK CONTROLLER .....	10
4.3. CONTROL SETTING .....	10
4.3.1. EFFECT .....	10
4.3.2. SPEED .....	10
4.3.3. LOOP .....	11
5. MENU SETTING .....	11
6. ADDITIONAL FUNCTION .....	13
6.1. CASCADE CONTROL .....	13
6.2. EXTERNAL CONTROL .....	14
6.2.1. DMX512 CONTROL .....	14
6.2.2. THE OTHER EXTERNAL CONTROL .....	16
6.3. TIME CONTROL .....	16
7. ADDRESSING .....	17
7.1. CHIP SUPPORTED .....	17
7.2. SUCCESSFULLY ADDRESSED AND SET PARAMETERS .....	18
7.3. ADDRESSABLE OPERATION .....	20
7.4. RE-ADDRESSING .....	21
7.5. PARAMETER SETTINGS .....	21
7.6. SEND THE SPECIFIED EFFECT AFTER ADDRESSING .....	22
7.7. ADDRESSING IN LED PLAYER .....	22
7.8. ADDRESSING CHECK .....	24

# CONTECTS

7.9. QUICKLY CONFIGURE LUMINAIRE PARAMETERS .....	25
7.9.1. SET THE ADDRESS PARAMETERS BY PLAYER .....	25
7.9.2. SET PARAMETERS OF DMX CHIP BY PLAYER .....	25
7.9.3. ADDRESS OPERATION ON CONTROLLER .....	26
7.9.4. SETTING PARAMETERS ON CONTROLLER .....	26
8. REMOTE OPERATION OF CLOUD CONTROL SYSTEM .....	27
8.1. GETTING THE DEVICE CODE .....	27
8.2. SETTING BY CLOUD SERVER OF WEBSITE .....	27
8.2.1. ACCESS STEPS ON WEBSITE .....	27
8.2.2. SET THE STATE BY CLOUD SERVER ON WEBSITE .....	28
8.2.3. ADDRESSING AND VERIFY LUMINAIRE BY CLOUD SERVER ON WEBSITE .....	28
8.2.4. CLOUD UPDATE ANIMATION FILE .....	29
8.2.5. COMPILING A CLOUD SCENARIO (TIME CONTROL) .....	32
8.3. SETTING BY CLOUD SERVER OF PHONE .....	33
8.3.1. ACCESS STEPS ON THE PHONE .....	33
8.3.2. SETING AND ADDRESSING BY CLOUD SERVER ON PHONE .....	33
9. IP SETTING IN PC .....	34
10. OUTPUT SD FILE AND COPY .....	35
10.1. OUTPUT SD FILE .....	35
10.2. COPY BY LED PLAYER .....	35
10.3. SD CARD COPY .....	36
11. BACK UP OR REPAIR EFFECTS FILE .....	36
12. UPDATE SD FILE OR FIRMWARE PROGRAMS LOCALLY .....	37
12.1. UPDATE ANIMATION ONLINE .....	37
12.2. UPDATE FIRMWARE PROGRAMS .....	37
12.2.1. GETTING FIRMWARE INFORMATION .....	37
12.3. UPDATE FIRMWARE VIA SD CARD .....	38
13. ERROR CODE AND TROUBLE SHOOTING .....	39
14. FITTINGS .....	40

## 1. FUNCTION OVERVIEW

1. Support both PC control and SD card control. Work with EN controller, can switch freely between PC control and SD card control which is flexible and convenient.
2. SN-510P with built-in 4G Internet module can access our cloud platform server through the wireless network of 4G iot card. Then update and remote call animation, choreograph and play scenes, write address, debugging verification. (For use outside China, please consult our company in advance and customize the equipment.)
3. When SN-510 works as master controller in intelligent control system, the animations of EN controller at the same link can be changed by just changing effect files in the SD card. Each SN-510 can control 450,000 channels or 100pcs controllers when it works as master controller in SD card control.
4. Time control, cascade sync, GPS satellite sync and DMX control are optional as additional functions.
5. Support for updating controller firmware and animations via SD card (or online from computer).
6. Built-in 30G storage, can be used to back up animations files in SD card. In the case of SD card corruption, file corruption, and no SD card, it can switch to play the animation of backup.
7. Specialized software of making animation is included, user can make their own effects.
8. The load capacity of different luminaires is different. (If frame frequency is not required, load capacity of each channel can be increased independently, and must test it in the factory.)

## 2. TECHNICAL PARAMETERS

### 2. 1. PRODUCT INFORMATION

- Cover material: Iron
- Input voltage: AC 100V - 240V
- Cascade signal: [Cascade of SN] optocoupler  
[PC - SN, SN - EN] SW Ethernet Protocol
- Loading: 25FPS: 360,000 channels. 20FPS: 450,000 channels
- Network interface: RJ45 Ethernet interface
- Output control: 100pcs controller at most
- Working power: <10W
- Working temperature: -25°C~70°C
- Relative humidity: ≤ 50% RH
- Transmission distance: Use UTP—unshielded twisted pair cable, distance between the controllers can be 100m.  
Please add signal amplifier if the distance of SN cascade is over 100m.  
For further distance of SW Ethernet Protocol, optical fiber converter can be used and the distance can reach 5 km.
- IP grade: IP20 (Prevent people from touching the components inside electrical appliance, prevent object which diameter is more than 12.5mm from getting in, no special protection to water or moisture.)
- Working environment: 1. Please do not install the controller in magnetic, high pressure, high temperature or seriously wet environment.

2. Please do connect the earth safely in order to reduce risks of fire and damage which cause by short circuit.
3. Please ensure AC100-240V power supply is used, and same polarity is connected between transformer and controller in order to guarantee the proper supply voltage.
4. No waterproof function in the control system, please pay attention on rainproof and waterproof during installing.

Net weight: 1.3 KG

Size: L285\*W156\*H44

(Unit mm)

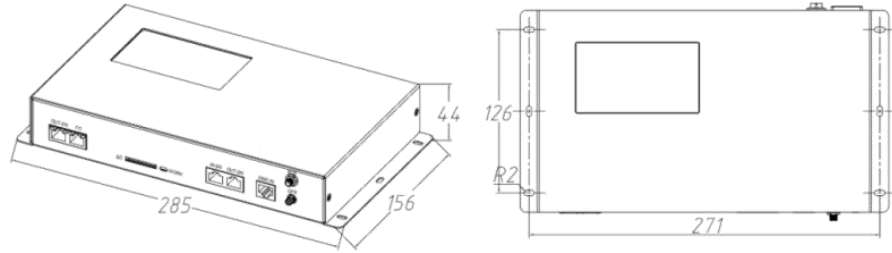

## 2. 2. COMPONENT

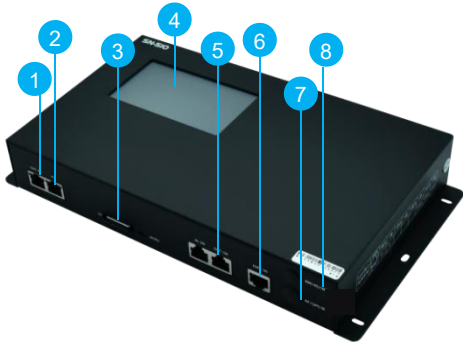

- |                                  |                          |                             |
|----------------------------------|--------------------------|-----------------------------|
| ① Connect with controller (RJ45) | ② Connect with PC (RJ45) | ③ SD card slot              |
| ④ 4.3" LED display               | ⑤ Uplink port (RJ45)     | ⑥ RS485 control port (RJ45) |
| ⑦ GPS antenna socket             | ⑧ RM/4G antenna socket   | ⑨ Power input AC100-240V    |
| ⑩ Power switch                   |                          |                             |

Note, The 7<sup>th</sup> and 8<sup>th</sup> interfaces are selected functions respectively. The interfaces are unavailable if the functions do not support.

## 2. 3. INDICATOR STATUS

Interface	Function	
RJ45 port (OUT-EN)	Output to connect EN controller.	
	Top left light	Indicator light, flicker synchronously with system frame rate.
	Top right light	Data light, flicker indicates normal connection and data transmission between master controller and slave controller.
RJ45 port (PC)	While connected with PC, it is used as an alternative scheme of the system. And it receive and send data in priority.	
	Top left light	Nonuse.
	Top right light	Data light, flicker indicates normal connection and data transmission between PC and master controller.
		The slave is sending the host's LAN synchronization signal.

Interface	Function
SD	SD card slot. The yellow light flickers while the controller reads data properly.

## 2. 4. MODEL AND FUNCTION DESCRIPTION

Function		Mode	SN-510	SN-510CG	SN-510P
Addressing / debug in standalone			✓	✓	✓
GPS synchronization				✓	✓
Cascade synchronization			✓	✓	✓
DMX512 console control			✓	✓	✓
Controlled by cloud platform	Update animation file				✓
	Switch animation program			✓	✓
	Scene coding				✓
	Addressing / debug			✓	✓

## 3. APPLICATION SOLUTION

### 3. 1. SN-510 DISENGAGES OUT OF CLOUD CONTROL

#### 3. 1. 1. WORKING WITH A SINGLE SN DEVICE

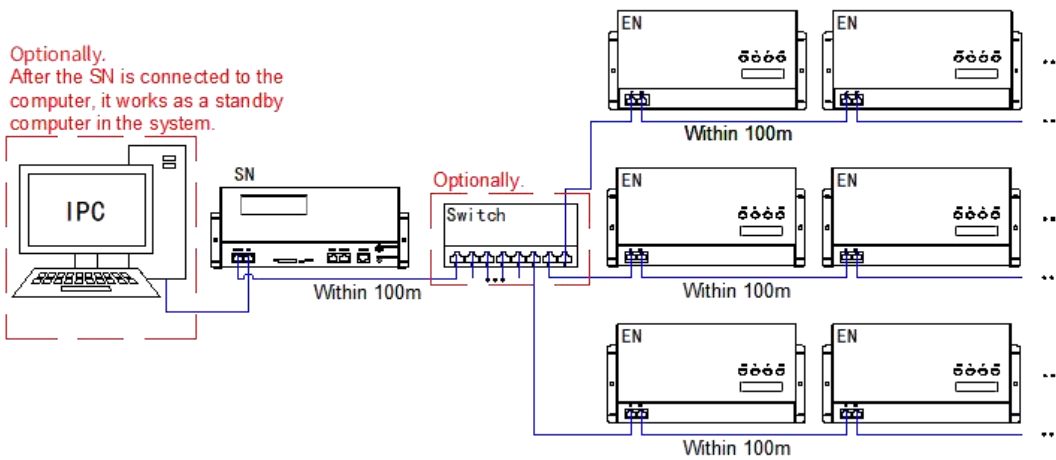

### 3.1.2. MULTIPLE SN DEVICES WORK SYNCHRONOUSLY

#### 3.1.2.1. OPTO-ISOLATOR SIGNAL SYNCHRONIZATION WORK

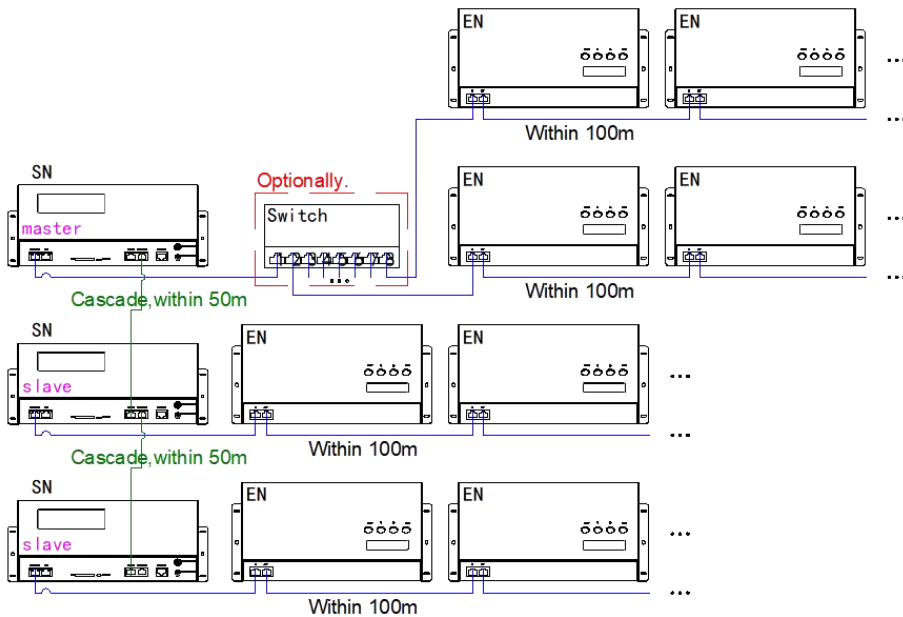

**Note:**

1. There is no switch between the masters, and the cascaded synchronization can be achieved hand in hand through Class 5 network cables (within 50 meters). Beyond 50 meters, please use LAN synchronization solution.

#### 3.1.2.2. LAN SIGNAL SYNCHRONIZATION WORK

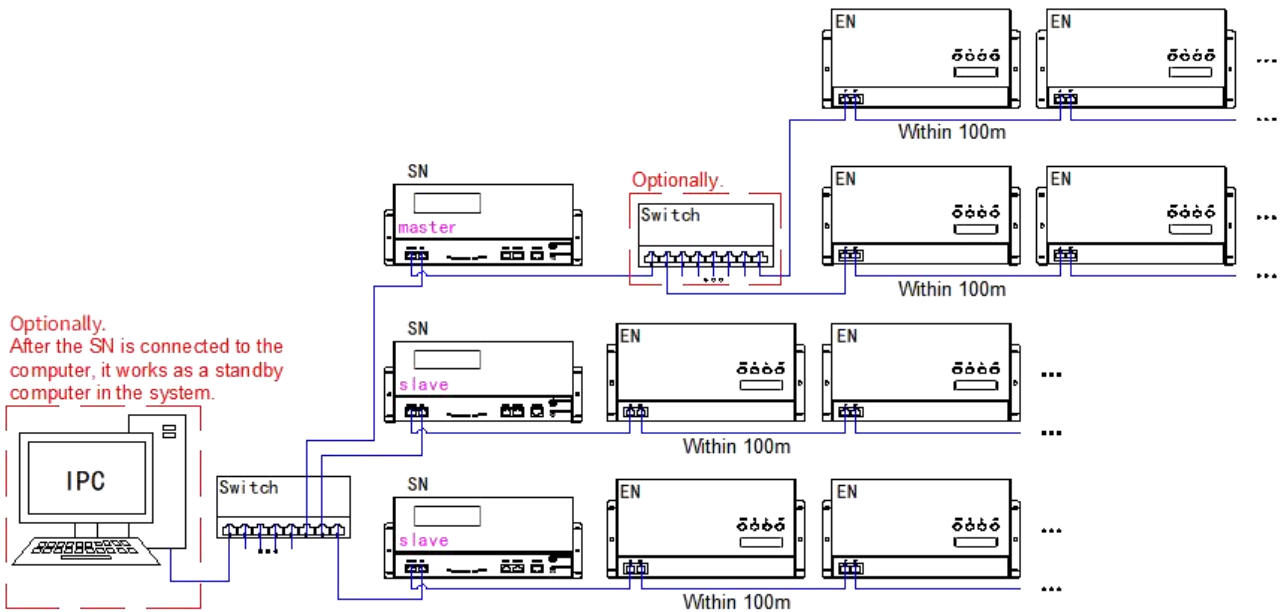

**Note:**

1. The switch must be used to synchronize the actual LAN between the master controllers.
2. The slave device in this solution does not have the SYNC symbol on the interface. You can identify the synchronization signal by blinking the green indicator of the PC port.

### 3.1.2.3. GPS SIGNAL SYNCHRONIZATION

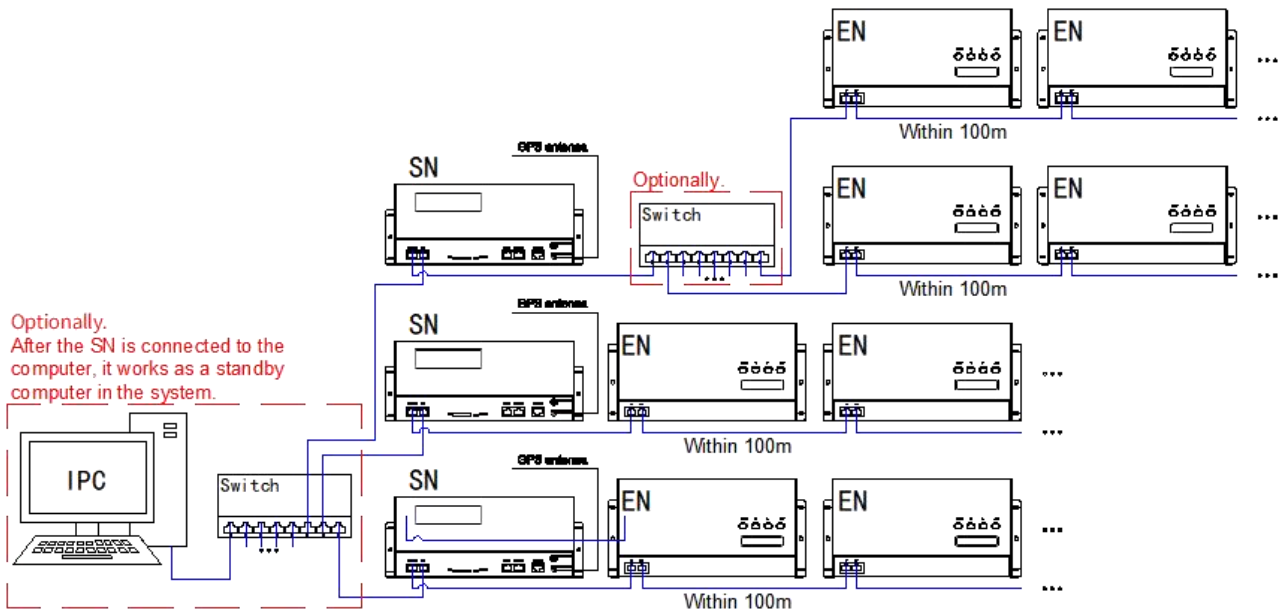

### 3.2. SN-510 DISENGAGES FROM CLOUD CONTROL

#### 3.2.1. A SINGLE SN DEVICE WORKED BY THE CLOUD PLATFORM

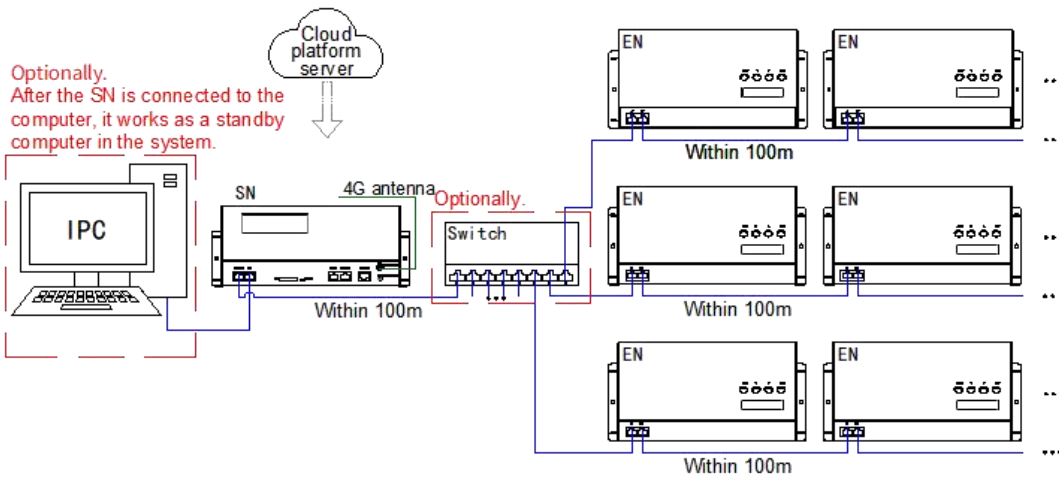

### 3.2.2. MULTIPLE SN DEVICES WORKED BY THE CLOUD PLATFORM

#### 3.2.2.1. OPTO-ISOLATOR SIGNAL SYNCHRONIZATION WORK BY CLOUD PLATFORM

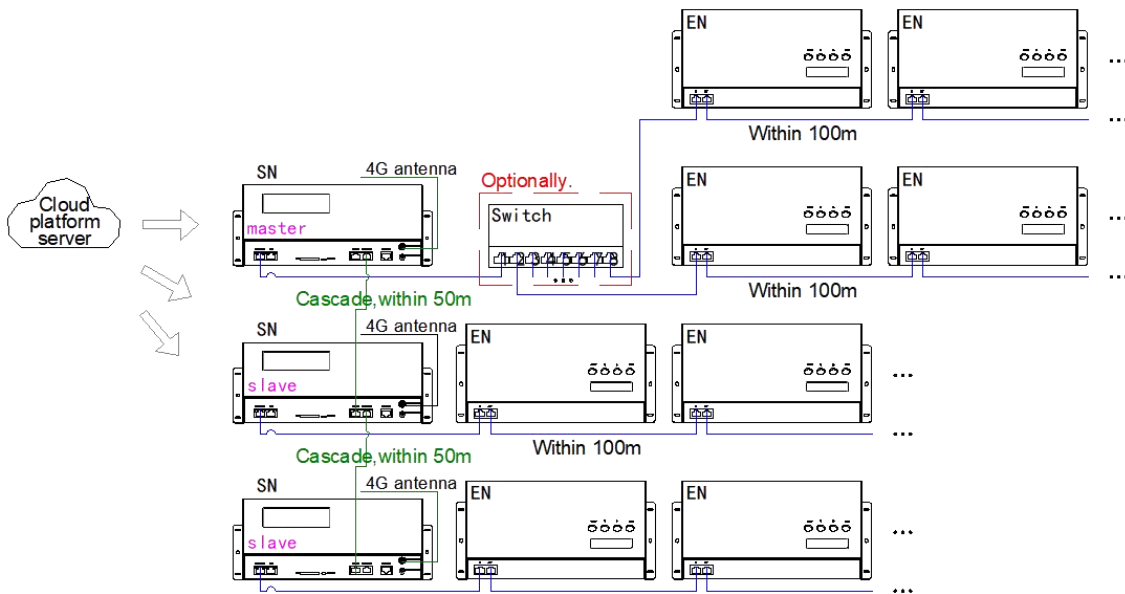

#### 3.2.2.2. LAN SIGNAL SYNCHRONIZATION WORK BY CLOUD PLATFORM

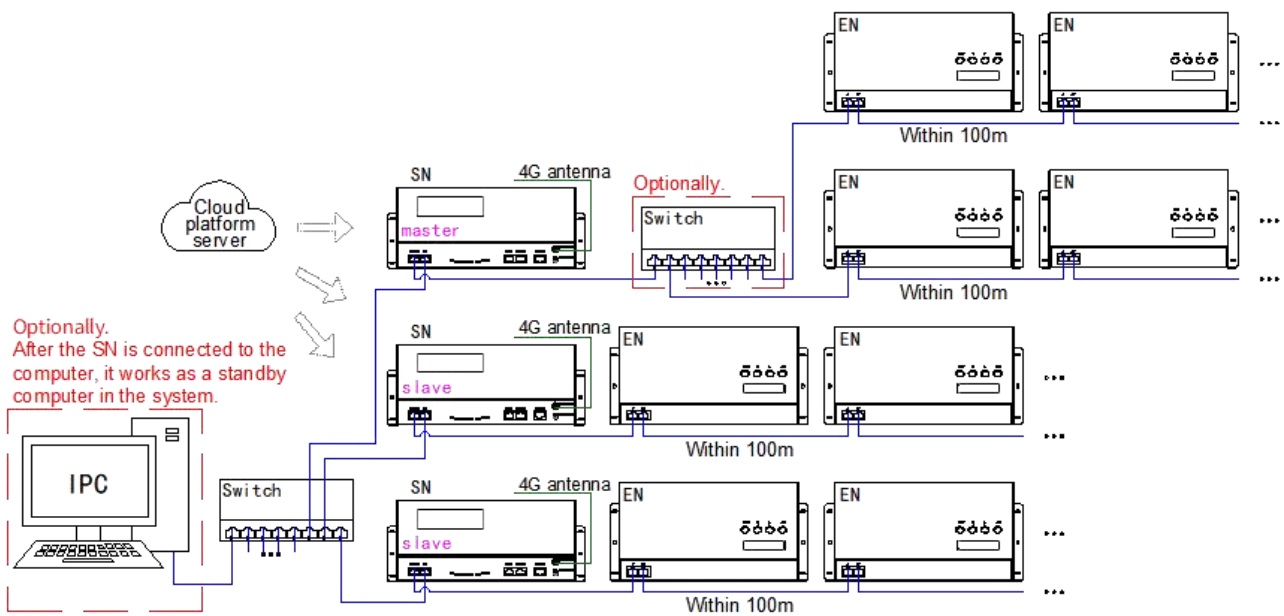

**Note:**

The slave of the SN-510P model also needs to be connected to the cloud platform to realize the online replacement effect and separate control and detection functions.

### 3.2.2.3. GPS SIGNAL SYNCHRONIZATION WORK BY CLOUD PLATFORM

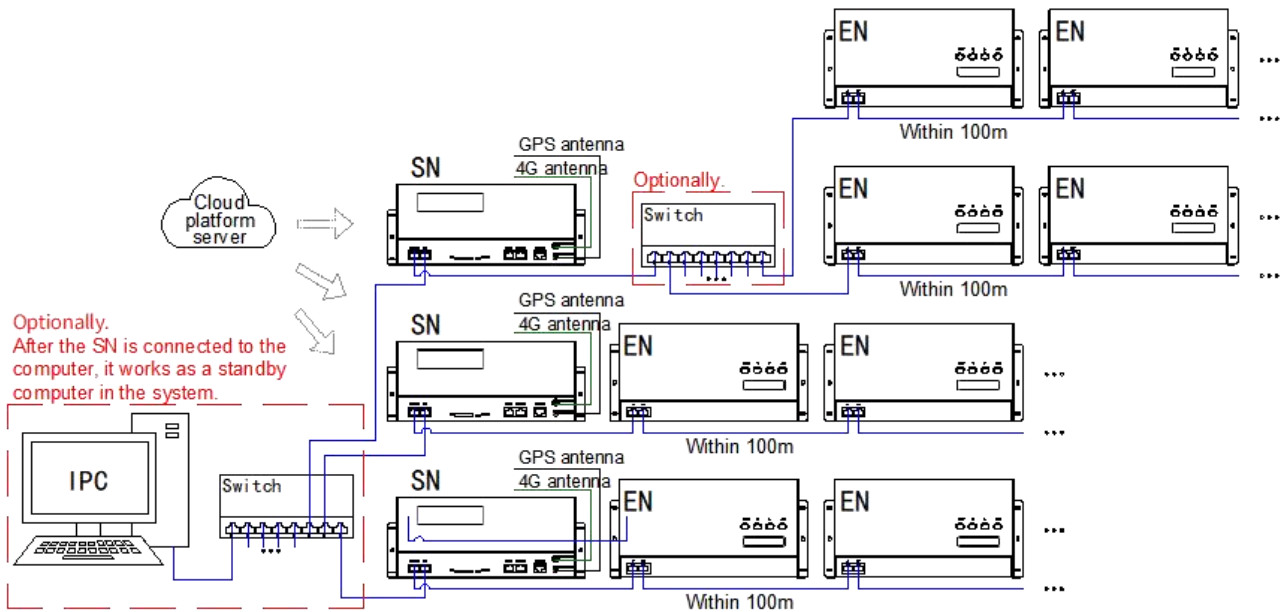

### 3.3. EXTERNAL CONTROL CABLE DIAGRAM

The controller supports Mod-bus (RTU transmission mode), COM, and DMX. Connect the network cable to the DMX-IN port of the controller and connect the other end to the corresponding external device to control the external device.

#### 3.3.1. DMX CONNECTION

Operation refers to the “DMX512 DECODING” section.

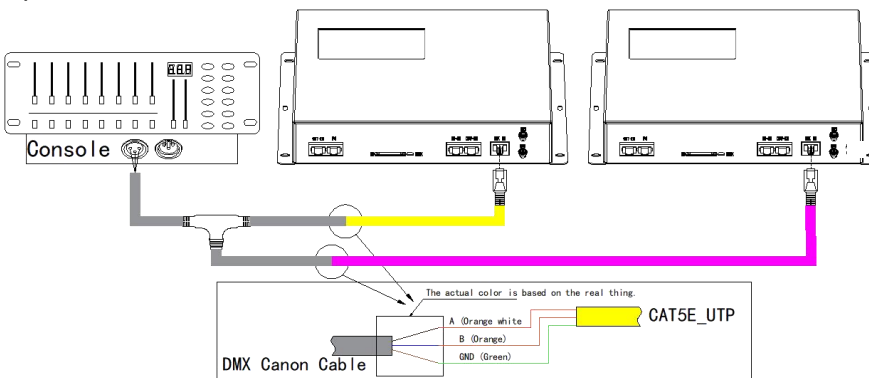

#### T568B structure

8	Brown	None
7	Brown white	None
6	Green	Signal GND
5	Blue white	None
4	Blue	None
3	Green white	None
2	Orange	Signal D-/B
1	Orange white	Signal D+/A

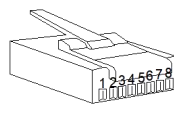
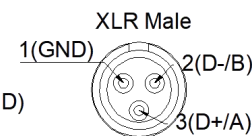
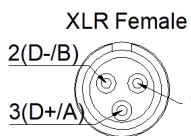

#### T568B structure

8	Brown	Signal GND
7	Brown white	Signal GND
6	Green	Signal GND
5	Blue white	None
4	Blue	None
3	Green white	None
2	Orange	Signal D-/B
1	Orange white	Signal D+/A

❖ [The pin position of The XLR is for reference only, and the final signal shall be subject to the actual XLR and DMX512 controller.](#)

### 3.3.2. OTHER EXTERNAL CONTROL DEVICES

The external device connected to the Mod-bus(RTU transmission mode) and COM protocol is a PC or PLC.

For computer control, the computer needs to be connected to the RJ45 port of the controller DMX\_IN through the USB to 485 device.

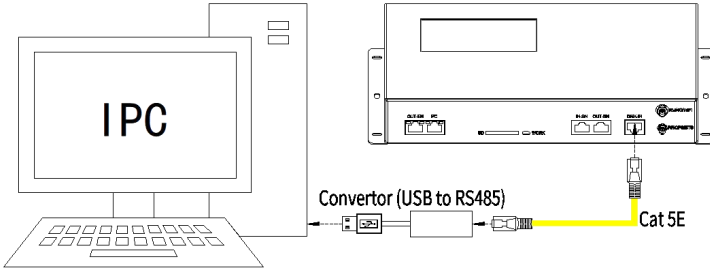

The conversion device is connected to the controller using a network cable.

Note the corresponding line sequence: pin 1 is D+/A, pin 2 is D-/B, and pin 6 is GND.

The wiring must be correct, otherwise it will cause uncontrollable.

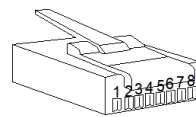

#### T568B structure

8	Brown	Signal GND
7	Brown white	Signal GND
6	Green	Signal GND
5	Blue white	None
4	Blue	None
3	Green white	None
2	Orange	Signal D-/B
1	Orange white	Signal D+/A

Note: Please contact us to obtain Mod-bus command protocol and COM protocol.

### 3.4. EXTENSION

#### 3.4.1. OPTICAL FIBER COMMUNICATION

Must use single mode transceivers. User can use single fiber or double fiber (alternative) according to on-site condition. The double fiber transceiver must be connected with two optical fibers. **Only two Ethernet interfaces for OUT-EN and PC are available.**

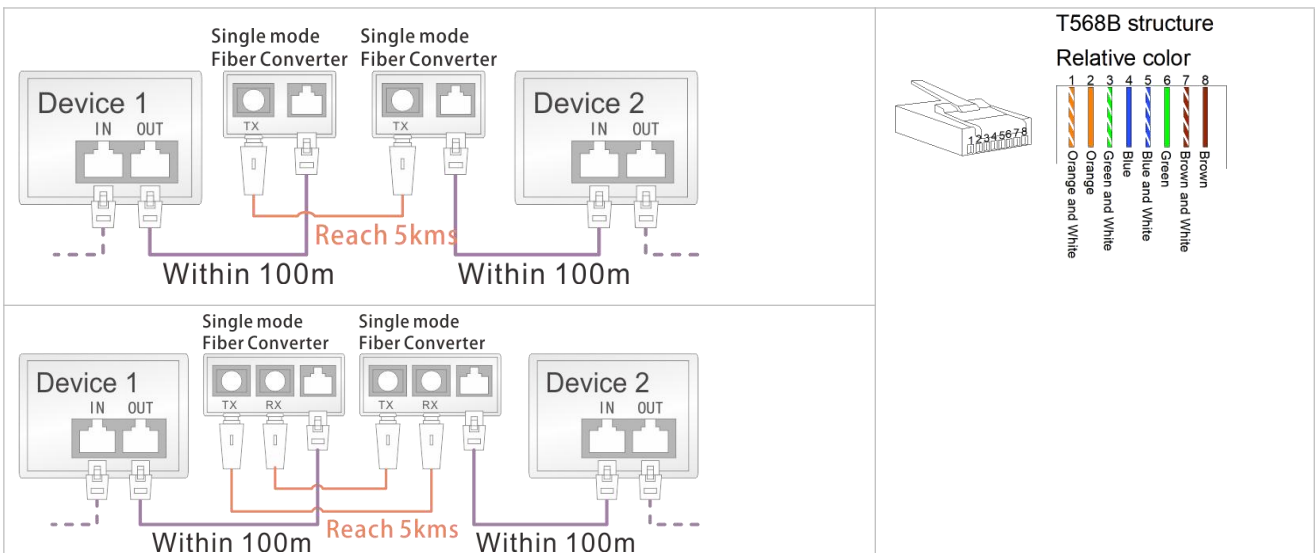

#### T568B structure Relative color

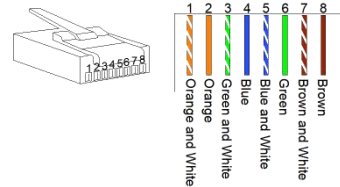

### 3.4.2. 4G SIGNAL NETWORKING

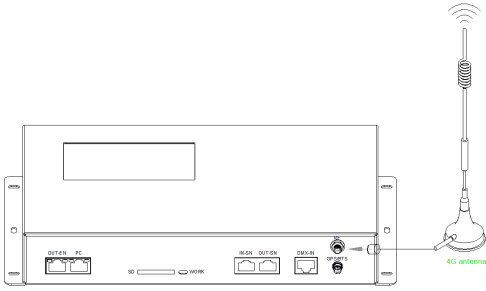

Wireless access network: The controller is equipped with 4G module and 4G iot card. Access to the antenna as shown in the figure, and access to 4G network can be realized by electrification.

**Attentions,**

- a) Try to place the antenna as high as possible, and close to the open air.
- b) Applicable to China only.

### 3.4.3. SYNCHRONOUS ANTENNA

2m GPS antenna is provided. User can purchase GPS antenna by your own. The longer the antenna is, the more difficult to search satellite. Connect the hardware and install the antenna correctly as required.

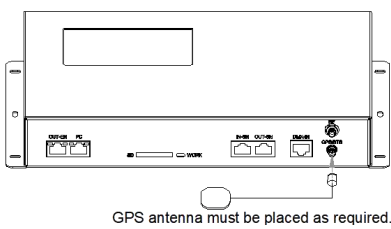

Antenna specification: GPS marine antenna with standard SMA interface.

- a. GPS Antenna should be installed in open space, there is no big shades (such as trees, iron towers etc.). GPS Antenna should be more than 2m away from the metal objects.
- b. Due to the satellite appearing on the equator more than other places, it preferably put the GPS antenna in the south of location for the north hemisphere.
- c. Please don't put GPS antenna around other transmitting and receiving equipment . Please keep them 2m away with each other.

## 4. BASIC OPERATION

### 4.1. INTERFACE INTRODUCTION

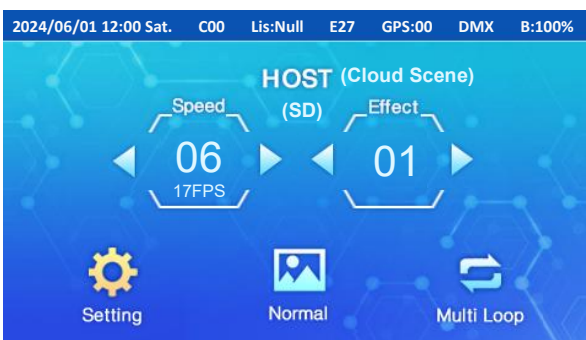

The icon of unsupported functions will not display.

Display	Introduction
Speed	Current speed.
Effect	Current effect.
HOST	Function display.
Cloud Scene	Playing cloud platform cloud scene. (SD time control).
SD/TF	The location of the currently playing effects file. SD card or the storage disk of the controller.
Setting	Select and enter the setting menu.
Normal	Current control mode.
Multiple / Single Loop	Current Play mode, press to switch.
2024/06/01 12:00 Sat.	Current setting date and time.
C**	Signal strength of 4G satellite.
E**	Error prompt for card reading.
List: Null	Current list of time control.
DMX	Controller access DMX512 console.
GPS:01	Signal strength of GPS satellite. The synchronization depends on the animation display.
B:100%	Current brightness of luminaire.

## 4. 2. UNLOCK CONTROLLER

Enter the screen saver state after no operation for a period. Double click the icon “Double Click” to unlock main interface.

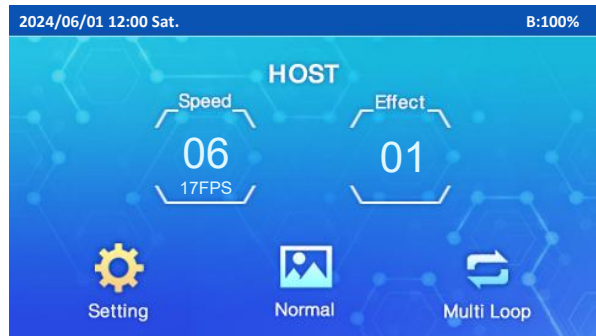
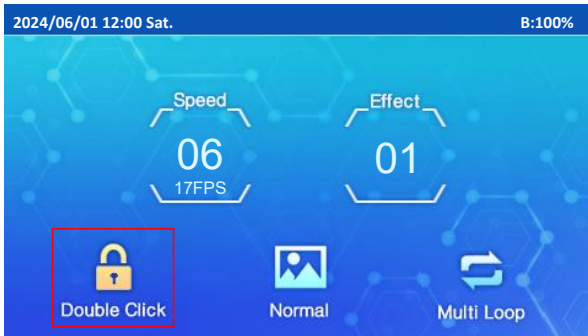

## 4. 3. CONTROL SETTING

### 4. 3. 1. EFFECT

Select the number under “Effect”, select ◀ / ▶ to change effect, and it will be changed from multiple loop to single loop.

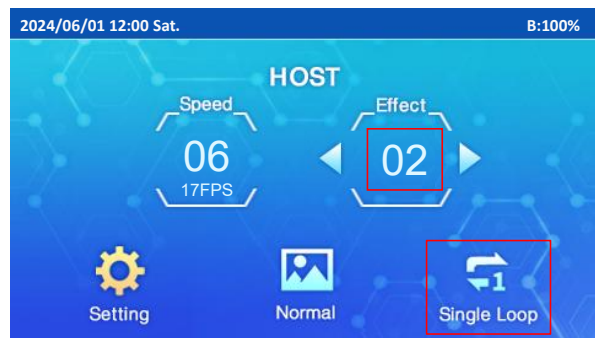
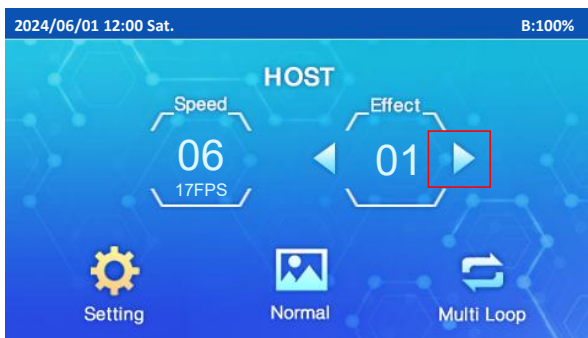

### 4. 3. 2. SPEED

Select the number under “Speed”, select ◀ / ▶ to set it. The less the value, the quicker the speed.

Parameters	Speed										
Interface	02	25ms	30ms	03	35ms	04	45ms	05	55ms	06	07
Frame Rate(ms)	20	25	30	33	35	40	45	50	55	60	70
(fps)	50	40	33	30	28	25	22	20	18	17	14
Interface	08	09	10	11	12	15	20	30	50	80	99
Frame Rate(ms)	80	90	100	110	120	150	200	300	500	1000	2000
(fps)	13	11	10	9	8	7	5	3	2	1	0.5

### 4.3.3. LOOP

Select "Multi Loop" to switch loop mode. There are Multiple Loop, Single Loop and Random play. Random play is unavailable when the controller supports GPS / BTS functions.

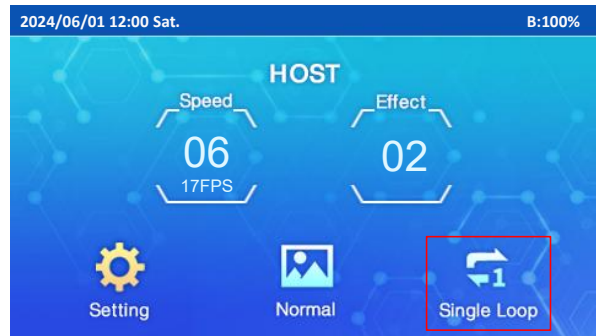
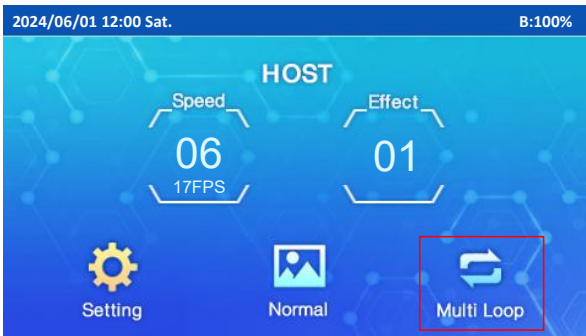

## 5. MENU SETTING

Select the "Settings" of main interface to enter the menu settings. All Settings are valid in real time.

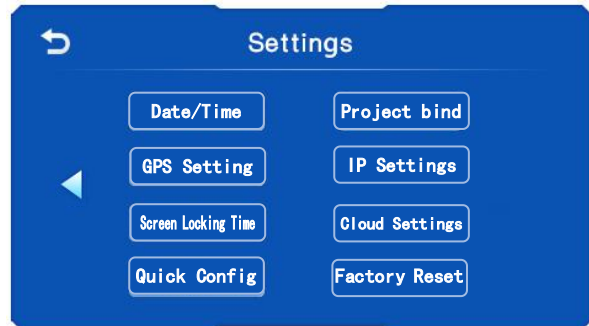
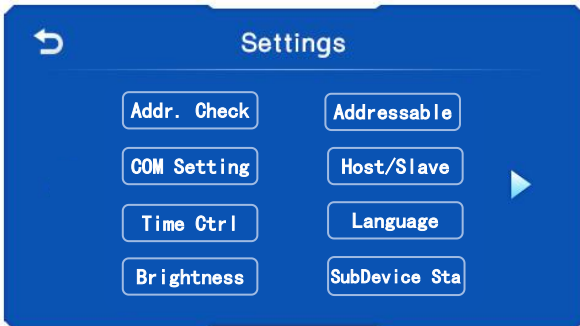

Selection	Interface	Instructions
Addressing Check	<p>Addressing Check</p> <p>Increment: 0001</p> <p>Check Mode: Pile up</p> <p>Current LEDS</p> <p>◀ 0001 ▶</p>	<p>Light up the luminaire to verify that its address is correct.</p> <p>Check Mode: Pile / Point.</p> <p>Current LEDS: Select ◀ / ▶ to set value.</p>
Addressable	<p>Addressable Mode</p> <p>Auto Addressable</p> <p>Again</p> <p>Parameter Setting</p>	<p>Address the luminaire.</p>
COM Settings	<p><u>COM control interface.</u></p> <p>COM.Settings</p> <p>Control Mode: COM</p> <p>Baud: 9600</p> <p><u>DMX control interface.</u></p> <p>DMX.Settings</p> <p>Control Mode: DMX</p> <p>DMX Mode: Standard</p> <p>More Setting</p> <p><u>The 3<sup>rd</sup> interface of DMX control.</u></p> <p>DMX Setting</p> <p>▲ 0 ▲ 0 ▲ 1</p> <p>▼ ▼ ▼</p> <p>Console reception mode: Digital Console</p> <p>DMX Channel Relation: Many to one</p>	<p>The COM control, Panel control or DMX console can be set as external control. It needs set the baud rate by COM control.</p> <p>It needs set the DMX control parameters by DMX control mode. Select ▼ / ▲ to set the address value. (Range: 1 - 504.) Select Digital Console / Push Rod console to set the controller receiving console mode.</p> <p>It needs set the Mod-bus address value by Modd-bus control mode. Select ▼ / ▲ to set the address value. (Range: 1 - 247.)</p>

Selection	Interface	Instructions
	<p><u>Mod-bus control interface.</u></p> <div style="border: 1px solid black; padding: 5px;"> <p>Com Settings</p> <p>Control Mode: Modbus</p> <p>Baud: 9600</p> <p style="text-align: right;"><a href="#">More Setting</a></p> </div> <p><u>The 3<sup>rd</sup> interface of DMX control.</u></p> <div style="border: 1px solid black; padding: 5px;"> <p>Modbus Address</p> <p style="text-align: center;">▲            ▲            ▲</p> <p style="text-align: center;">0            0            1</p> <p style="text-align: center;">▼            ▼            ▼</p> <p style="text-align: center;">Modbus 地址最大值 247</p> <p style="text-align: right;"><a href="#">Confirm</a></p> </div>	
Host/Slave	Host/Slave	Set the controller to host or slave.
Time Control	<div style="border: 1px solid black; padding: 5px;"> <p>Time Control</p> <p style="text-align: center;">Close</p> <p style="text-align: center;">SD Card</p> </div>	Set the controller to time control.
Language	<div style="border: 1px solid black; padding: 5px;"> <p>LANGUAGE</p> <p style="text-align: center;">中文</p> <p style="text-align: center;">English</p> </div>	Set the interface language.
Brightness	<div style="border: 1px solid black; padding: 5px;"> <p style="text-align: center;">Brightness</p> <p>Red: ◀100%▶    Green: ◀100%▶</p> <p>Blue: ◀100%▶    White: ◀100%▶</p> <p>All: ◀            100%            ▶</p> </div>	Select ◀ / ▶ to set value. (Range is 0%~100%.) 0% is black and 100% is the brightest. All channels are valid independently.
SubDevice Sta.	<div style="border: 1px solid black; padding: 5px;"> <p style="text-align: center;">SubDevice Status</p> <p style="text-align: center;"><a href="#">Click to Search</a></p> </div>	Click to search for the status of all controllers carried by the current SN controller (maximum 100 controllers).
Date/Time	<div style="border: 1px solid black; padding: 5px;"> <p style="text-align: center;">Date/ Time</p> <p>Time zone: ◀ UTC +8 ▶</p> <p style="text-align: center;">2024/06/01</p> <p style="text-align: center;">12:00</p> </div>	<ol style="list-style-type: none"> <li>Select ◀ ▶ to set time zone. Range is -11 -+12. <b>Only for the GPS synchronization.</b></li> <li>Select the value to enter the time setting interface. <b>It switches GPS time when GPS signal is received.</b></li> </ol>
GPS Settings	<div style="border: 1px solid black; padding: 5px;"> <p style="text-align: center;">GPS Settings</p> <p>Sync Switch:            开/on</p> <p>TimeList Mode:        Standard</p> <p>Sec:            ◀            00            ▶</p> <p>Msec:           ◀            0000           ▶</p> </div>	<p>Sync Switch: Enable GPS synchronization.</p> <p>Time List Mode: In the state of GPS synchronization, enable time control function can choose "standard" or "compatible".</p> <p>Standard: It starts at the first frame of the list.</p> <p>Compatible: It automatically switches to the start of the corresponding frame sequence according to the time.</p> <p>Seconds/milliseconds: Sets the time difference for each controller so that all effects are in sync.</p>
Screen Locking Time	<div style="border: 1px solid black; padding: 5px;"> <p style="text-align: center;">Screen Locking Time</p> <p style="text-align: center;">◀            1 mins            ▶</p> </div>	Select ◀ / ▶ to set value. (30 seconds, 1 minute, 5 minutes, 30 minutes and perpetual.)
Quick Config	<div style="border: 1px solid black; padding: 5px;"> <p style="text-align: center;">Quick Config</p> <p style="text-align: center;">Address Lights</p> <p style="text-align: center;">Config Lights</p> </div>	Configure the parameters and address values of the luminaire according to the file parameters in the SD card. For details, see the QUICKLY CONFIGURE LUMINAIRE PARAMETERS section.
Project bind	<div style="border: 1px solid black; padding: 5px;"> <p style="text-align: center;">Project bind</p> <div style="display: flex; align-items: center;"> <div> <p>123B56</p> <p>888543</p> <p>210C01</p> <p>234567</p> </div> </div> <p>ICCID: 0 2 3 4 7 5 4 8 9 1</p> <p style="text-align: center;">9 8 A 7 6 5 4 3 2 1</p> </div>	<p>Scan the QR code through the cloud platform operation or manually enter 24 characters to access the cloud platform to achieve remote control.</p> <p><b>(For use outside China, please consult our company in advance and customize the equipment.)</b></p>

Selection	Interface	Instructions
IP Settings	<p style="text-align: center;">IP Settings</p> <p style="text-align: center;">▲ ▲ ▲ ▲</p> <p>IP address: 002 000 000 033</p> <p style="text-align: center;">▼ ▼ ▼ ▼</p> <p>IP address: 002.000.000.033 Subnet mask: 002.000.000.001 Default gateway: 255.000.000.000</p>	Set the IP address of the SN controller.
Cloud Settings	<p style="text-align: center;">Cloud Settings</p> <p>Cloud Switch: 开/on</p> <p>Node Number: ◀ 001 ▶</p>	Enable and connect to the cloud server. And select ◀ / ▶ to set node value.
Restore	<p style="text-align: center;">Restore Factory Setting</p> <p style="text-align: center;">Yes No</p>	Restore the factory settings.

## 6. ADDITIONAL FUNCTION

### 6. 1. CASCADE CONTROL

The project needs to cascade multiple controllers to control. Switches can be used to form a LAN, or SN controllers can play simultaneously hand in hand. See "APPLICATION SOLUTION" for connection.

1. On the Setup parameters screen, set it from the host to the slave.

LAN synchronization can be determined only by the PC port indicator on the controller.

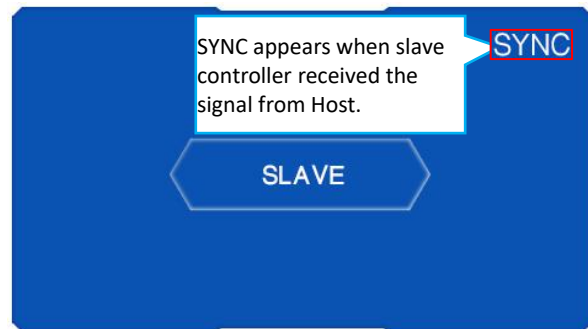
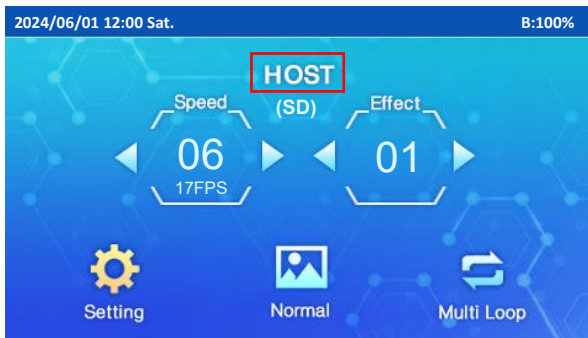

2. Setup multiple SN controllers in the LED Player.

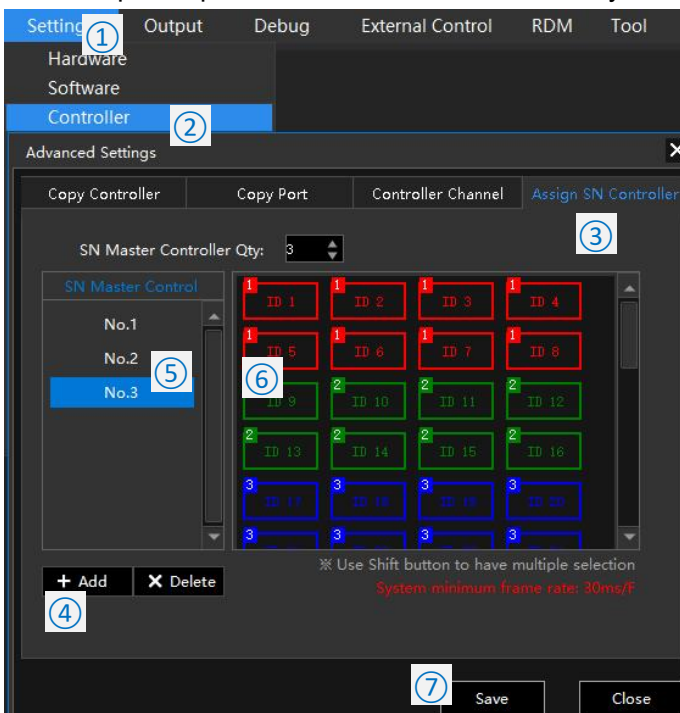

- ① Click "Setting".
- ② Click "Controller".
- ③ Click "Assign SN Controller".
- ④ Click "+Add" to increase SN controller.
- ⑤ Click "No.2".
- ⑥ Click "ID9, ID10, ID11, ID12, ID13, ID14, ID15, ID16".
- ⑦ Click "Save" and close the window.
- ⑧ Output the SD card file and copy it into SD card.

Multiple master controls can be repeated point 5 and 6 operation.

Note, if there is only one SN controller in the project, we can skip this setting and directly output the SD card file and copy.

## 6. 2. EXTERNAL CONTROL

### 6. 2. 1. DMX512 CONTROL

User can adjust the effect, speed and brightness by DMX512 console.

The same or different addresses can be set in the controller, so that DMX512 console is able to control several controllers with same or different effects. The actual effect is determined by SD card and mode selection of the controller. Connection refers to the DMX CONNECTION section.

Select ▼ / ▲ to set DMX address value.

Different control modes correspond to different functions of channels. And the address setting formula is related to the control mode. They are:

Standard,  $(N-1) * 8 + 1$

Compatible,  $(N-1) * 12 + 1$

Effect 00 is black and Effect 99 is playing in multiple loop.

Select Filter / Immediate to set the controller receiving console mode.

Push Rod Console: When DMX console stops operating for 0.5 seconds, it responds to the control luminaire.

Digital Console: It responds to the control luminaire of DMX console parameters.

Set the numerical interval of the console,

[Standard] Many to one. (Channel values are evenly distributed by level.)

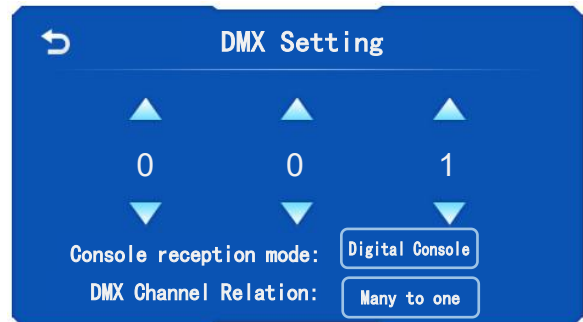

CH	01		02		03		04		05		06		07		08		10					
	Set	Range	Set	Range	Set	Range	Set	Range	Set	Range	Set	Range	Set	Range	Set	Range	Set	Range				
Position of Push Road	90	225 ~ 255	09	225 ~ 255	99	240 ~ 255	100	200 ~ 255	100	200 ~ 255	100	200 ~ 255	100	200 ~ 255	100	200 ~ 255	100	200 ~ 255	Random	171 ~ 255		
	80	200 ~ 224	08	200 ~ 224	80	224 ~ 239	99	198 ~ 199	99	198 ~ 199	99	198 ~ 199	99	198 ~ 199	99	198 ~ 199	99	198 ~ 199			Multiple	85 ~ 170
	70	175 ~ 199	07	175 ~ 199	30	192 ~ 207	97	194 ~ 195	97	194 ~ 195	97	194 ~ 195	97	194 ~ 195	97	194 ~ 195	97	194 ~ 195				
	60	150 ~ 174	06	150 ~ 174	20	176 ~ 191	96	192 ~ 193	96	192 ~ 193	96	192 ~ 193	96	192 ~ 193	96	192 ~ 193	96	192 ~ 193				
	50	125 ~ 149	05	125 ~ 149	15	160 ~ 175	95	190 ~ 191	95	190 ~ 191	95	190 ~ 191	95	190 ~ 191	95	190 ~ 191	95	190 ~ 191				
	40	100 ~ 124	04	100 ~ 124	12	144 ~ 159	11	128 ~ 143	10	112 ~ 127	7	14 ~ 15	7	14 ~ 15	7	14 ~ 15	7	14 ~ 15	7	14 ~ 15		
	30	75 ~ 99	03	75 ~ 99	8	80 ~ 95	6	12 ~ 13	6	12 ~ 13	6	12 ~ 13	6	12 ~ 13	6	12 ~ 13	6	12 ~ 13	6	12 ~ 13		
	20	50 ~ 74	02	50 ~ 74	7	64 ~ 79	5	10 ~ 11	5	10 ~ 11	5	10 ~ 11	5	10 ~ 11	5	10 ~ 11	5	10 ~ 11	5	10 ~ 11		
	10	25 ~ 49	01	25 ~ 49	6	48 ~ 63	4	8 ~ 9	4	8 ~ 9	4	8 ~ 9	4	8 ~ 9	4	8 ~ 9	4	8 ~ 9	4	8 ~ 9		
	00	0 ~ 24	00	0 ~ 24	5	32 ~ 47	3	6 ~ 7	3	6 ~ 7	3	6 ~ 7	3	6 ~ 7	3	6 ~ 7	3	6 ~ 7	3	6 ~ 7		
				4	16 ~ 31	2	4 ~ 5	2	4 ~ 5	2	4 ~ 5	2	4 ~ 5	2	4 ~ 5	2	4 ~ 5	2	4 ~ 5			
				3	0 ~ 15	1	2 ~ 3	1	2 ~ 3	1	2 ~ 3	1	2 ~ 3	1	2 ~ 3	1	2 ~ 3	1	2 ~ 3			
				0	0 ~ 1	0	0 ~ 1	0	0 ~ 1	0	0 ~ 1	0	0 ~ 1	0	0 ~ 1	0	0 ~ 1	0	0 ~ 1			

[Standard] Ten to one. (Channel values are incremented by tens.)

CH	01		02		03		04		05		06		07		08		10					
	Set	Range	Set	Range	Set	Range	Set	Range	Set	Range	Set	Range	Set	Range	Set	Range	Set	Range				
Position of Push Road	90	90 ~ 89	09	90 ~ 89	99	240 ~ 255	100	200 ~ 255	100	200 ~ 255	100	200 ~ 255	100	200 ~ 255	100	200 ~ 255	100	200 ~ 255	Random	20 ~ 255		
	80	80 ~ 89	08	80 ~ 89	80	230 ~ 239	99	198 ~ 199	99	198 ~ 199	99	198 ~ 199	99	198 ~ 199	99	198 ~ 199	99	198 ~ 199			Multiple	10 ~ 19
	70	70 ~ 79	07	70 ~ 79	50	220 ~ 229	98	196 ~ 197	98	196 ~ 197	98	196 ~ 197	98	196 ~ 197	98	196 ~ 197	98	196 ~ 197				
	60	60 ~ 69	06	60 ~ 69	30	210 ~ 219	97	194 ~ 195	97	194 ~ 195	97	194 ~ 195	97	194 ~ 195	97	194 ~ 195	97	194 ~ 195				
	50	50 ~ 59	05	50 ~ 59	20	200 ~ 209	96	192 ~ 193	96	192 ~ 193	96	192 ~ 193	96	192 ~ 193	96	192 ~ 193	96	192 ~ 193				
	40	40 ~ 49	04	40 ~ 49	15	150 ~ 159	95	190 ~ 191	95	190 ~ 191	95	190 ~ 191	95	190 ~ 191	95	190 ~ 191	95	190 ~ 191				
	30	30 ~ 39	03	30 ~ 39	12	120 ~ 149	11	110 ~ 119	10	100 ~ 109	7	14 ~ 15	7	14 ~ 15	7	14 ~ 15	7	14 ~ 15	7	14 ~ 15		
	20	20 ~ 29	02	20 ~ 29	8	80 ~ 89	6	12 ~ 13	6	12 ~ 13	6	12 ~ 13	6	12 ~ 13	6	12 ~ 13	6	12 ~ 13	6	12 ~ 13		
	10	10 ~ 19	01	10 ~ 19	7	70 ~ 79	5	10 ~ 11	5	10 ~ 11	5	10 ~ 11	5	10 ~ 11	5	10 ~ 11	5	10 ~ 11	5	10 ~ 11		
	00	0 ~ 9	00	0 ~ 9	6	60 ~ 69	4	8 ~ 9	4	8 ~ 9	4	8 ~ 9	4	8 ~ 9	4	8 ~ 9	4	8 ~ 9	4	8 ~ 9		
				5	50 ~ 59	3	6 ~ 7	3	6 ~ 7	3	6 ~ 7	3	6 ~ 7	3	6 ~ 7	3	6 ~ 7	3	6 ~ 7			
				4	40 ~ 49	2	4 ~ 5	2	4 ~ 5	2	4 ~ 5	2	4 ~ 5	2	4 ~ 5	2	4 ~ 5	2	4 ~ 5			
				3	0 ~ 39	1	2 ~ 3	1	2 ~ 3	1	2 ~ 3	1	2 ~ 3	1	2 ~ 3	1	2 ~ 3	1	2 ~ 3			
				0	0 ~ 1	0	0 ~ 1	0	0 ~ 1	0	0 ~ 1	0	0 ~ 1	0	0 ~ 1	0	0 ~ 1	0	0 ~ 1			

[Standard] One to one. (Channel values are incremented by ones.)

CH.	01			02			03			04			05			06			07			10		
	Set	Range		Set	Range		Set	Range		Set	Range		Set	Range		Set	Range		Set	Range		Set	Range	
Position of Push Rod	97	97	~ 255	99	18	~ 255	100	100	~ 255	100	100	~ 255	100	100	~ 255	100	100	~ 255	100	100	~ 255	Random	2	~ 255
	96	96	~ 255	80	17	~ 255	99	99	~ 255	99	99	~ 255	99	99	~ 255	99	99	~ 255	99	99	~ 255			
	95	95	~ 255	50	16	~ 255	98	98	~ 255	98	98	~ 255	98	98	~ 255	98	98	~ 255	98	98	~ 255			
	94	94	~ 255	30	15	~ 255	97	97	~ 255	97	97	~ 255	97	97	~ 255	97	97	~ 255	97	97	~ 255			
	93	93	~ 255	20	14	~ 255	96	96	~ 255	96	96	~ 255	96	96	~ 255	96	96	~ 255	96	96	~ 255			
	92	92	~ 255	15	13	~ 255	95	95	~ 255	95	95	~ 255	95	95	~ 255	95	95	~ 255	95	95	~ 255			
		...		12	12		...			...			...			...			...			Multiple	1	~ 1
				11	11																			
				10	10																			
	07	7	~ 1	9	9	~ 1	7	7	~ 1	7	7	~ 1	7	7	~ 1	7	7	~ 1	7	7	~ 1			
	06	6	~ 1	8	8	~ 1	6	6	~ 1	6	6	~ 1	6	6	~ 1	6	6	~ 1	6	6	~ 1			
	05	5	~ 1	7	7	~ 1	5	5	~ 1	5	5	~ 1	5	5	~ 1	5	5	~ 1	5	5	~ 1			
	04	4	~ 1	6	6	~ 1	4	4	~ 1	4	4	~ 1	4	4	~ 1	4	4	~ 1	4	4	~ 1			
	03	3	~ 1	5	5	~ 1	3	3	~ 1	3	3	~ 1	3	3	~ 1	3	3	~ 1	3	3	~ 1			
	02	2	~ 1	4	4	~ 1	2	2	~ 1	2	2	~ 1	2	2	~ 1	2	2	~ 1	2	2	~ 1			
	01	1	~ 1	3	3	~ 1	1	1	~ 1	1	1	~ 1	1	1	~ 1	1	1	~ 1	1	1	~ 1			
00	0	~ 1	3	0 ~ 3		1	0	~ 1	0	0	~ 1	0	0	~ 1	0	0	~ 1	0	0	~ 1				

[Compatible] Many to one. (Channel values are evenly distributed by level.)

Channel	01	02		03		04		05		06	07	08		09		10		11		12						
		Set	Range	Set	Range	Set	Range	Set	Range			Bright_Overall	Bright_CH.R	Bright_CH.G	Bright_CH.B	Bright_CH.W	Set	Range	Set	Range						
Position of Push Rod	None	99	240	~ 255	Dynamic	Audio	204	~ 255	90	225 ~ 255	09	225 ~ 255	None	100	200 ~ 255	100	200 ~ 255	100	200 ~ 255	100	200 ~ 255	100	200 ~ 255	100	200 ~ 255	
		80	224	~ 239			80	200 ~ 224	08	200 ~ 224	99	198 ~ 199		99	198 ~ 199	99	198 ~ 199	99	198 ~ 199	99	198 ~ 199	99	198 ~ 199			
		50	208	~ 223			70	175 ~ 199	07	175 ~ 199	98	196 ~ 197		98	196 ~ 197	98	196 ~ 197	98	196 ~ 197	98	196 ~ 197	98	196 ~ 197			
		30	192	~ 207			60	150 ~ 174	06	150 ~ 174	97	194 ~ 195		97	194 ~ 195	97	194 ~ 195	97	194 ~ 195	97	194 ~ 195	97	194 ~ 195			
		20	176	~ 191			50	125 ~ 149	05	125 ~ 149	96	192 ~ 193		96	192 ~ 193	96	192 ~ 193	96	192 ~ 193	96	192 ~ 193	96	192 ~ 193			
		15	160	~ 175			40	100 ~ 124	04	100 ~ 124	95	190 ~ 191		95	190 ~ 191	95	190 ~ 191	95	190 ~ 191	95	190 ~ 191	95	190 ~ 191			
		12	144	~ 159			30	75 ~ 99	03	75 ~ 99	94	188 ~ 189		94	188 ~ 189	94	188 ~ 189	94	188 ~ 189	94	188 ~ 189	94	188 ~ 189			
		11	128	~ 143			20	50 ~ 74	02	50 ~ 74	93	186 ~ 187		93	186 ~ 187	93	186 ~ 187	93	186 ~ 187	93	186 ~ 187	93	186 ~ 187			
		10	112	~ 127		10	25 ~ 49	01	25 ~ 49	92	184 ~ 185	92		184 ~ 185	92	184 ~ 185	92	184 ~ 185	92	184 ~ 185	92	184 ~ 185				
		9	96	~ 111		00	0 ~ 24	00	0 ~ 24	91	182 ~ 183	91		182 ~ 183	91	182 ~ 183	91	182 ~ 183	91	182 ~ 183	91	182 ~ 183				
		8	80	~ 95		Spectrum	Voice	52	~ 102	80	80 ~ 89	08		80 ~ 89	99	198 ~ 199	99	198 ~ 199	99	198 ~ 199	99	198 ~ 199	99	198 ~ 199	99	198 ~ 199
		7	64	~ 79				40	40 ~ 49	04	40 ~ 49	98		196 ~ 197	98	196 ~ 197	98	196 ~ 197	98	196 ~ 197	98	196 ~ 197	98	196 ~ 197		
		6	48	~ 63				30	30 ~ 39	03	30 ~ 39	97		194 ~ 195	97	194 ~ 195	97	194 ~ 195	97	194 ~ 195	97	194 ~ 195	97	194 ~ 195		
		5	32	~ 47				20	20 ~ 29	02	20 ~ 29	96		192 ~ 193	96	192 ~ 193	96	192 ~ 193	96	192 ~ 193	96	192 ~ 193	96	192 ~ 193		
		4	16	~ 31				10	10 ~ 19	01	10 ~ 19	95		190 ~ 191	95	190 ~ 191	95	190 ~ 191	95	190 ~ 191	95	190 ~ 191	95	190 ~ 191		
		3	0	~ 15				00	0 ~ 9	00	0 ~ 9	94		188 ~ 189	94	188 ~ 189	94	188 ~ 189	94	188 ~ 189	94	188 ~ 189	94	188 ~ 189		
			20	20 ~ 29	02			20 ~ 29	93	186 ~ 187	93	186 ~ 187	93	186 ~ 187	93	186 ~ 187	93	186 ~ 187	93	186 ~ 187						
			10	10 ~ 19	01			10 ~ 19	92	184 ~ 185	92	184 ~ 185	92	184 ~ 185	92	184 ~ 185	92	184 ~ 185	92	184 ~ 185						
			00	0 ~ 9	00	0 ~ 9	91	182 ~ 183	91	182 ~ 183	91	182 ~ 183	91	182 ~ 183	91	182 ~ 183	91	182 ~ 183								
			00	0 ~ 9	00	0 ~ 9	90	180 ~ 181	90	180 ~ 181	90	180 ~ 181	90	180 ~ 181	90	180 ~ 181	90	180 ~ 181								

[Compatible] Ten to one. (Channel values are incremented by tens.)

Channel	01	02		03		04		05		06	07	08		09		10		11		12						
		Set	Range	Set	Range	Set	Range	Set	Range			Bright_Overall	Bright_CH.R	Bright_CH.G	Bright_CH.B	Bright_CH.W	Set	Range	Set	Range						
Position of Push Rod	None	99	240	~ 255	Dynamic	Audio	40	~ 255	90	90 ~ 255	09	90 ~ 255	None	100	200 ~ 255	100	200 ~ 255	100	200 ~ 255	100	200 ~ 255	100	200 ~ 255	100	200 ~ 255	
		80	230	~ 239			80	80 ~ 89	08	80 ~ 89	99	198 ~ 199		99	198 ~ 199	99	198 ~ 199	99	198 ~ 199	99	198 ~ 199	99	198 ~ 199			
		50	220	~ 229			70	70 ~ 79	07	70 ~ 79	98	196 ~ 197		98	196 ~ 197	98	196 ~ 197	98	196 ~ 197	98	196 ~ 197	98	196 ~ 197			
		30	210	~ 219			60	60 ~ 69	06	60 ~ 69	97	194 ~ 195		97	194 ~ 195	97	194 ~ 195	97	194 ~ 195	97	194 ~ 195	97	194 ~ 195			
		20	200	~ 209			50	50 ~ 59	05	50 ~ 59	96	192 ~ 193		96	192 ~ 193	96	192 ~ 193	96	192 ~ 193	96	192 ~ 193	96	192 ~ 193			
		15	150	~ 199			40	40 ~ 49	04	40 ~ 49	95	190 ~ 191		95	190 ~ 191	95	190 ~ 191	95	190 ~ 191	95	190 ~ 191	95	190 ~ 191			
		12	120	~ 149			30	30 ~ 39	03	30 ~ 39	94	188 ~ 189		94	188 ~ 189	94	188 ~ 189	94	188 ~ 189	94	188 ~ 189	94	188 ~ 189			
		11	110	~ 119			20	20 ~ 29	02	20 ~ 29	93	186 ~ 187		93	186 ~ 187	93	186 ~ 187	93	186 ~ 187	93	186 ~ 187	93	186 ~ 187			
		10	100	~ 109		10	10 ~ 19	01	10 ~ 19	92	184 ~ 185	92		184 ~ 185	92	184 ~ 185	92	184 ~ 185	92	184 ~ 185	92	184 ~ 185				
		9	90	~ 99		00	0 ~ 9	00	0 ~ 9	91	182 ~ 183	91		182 ~ 183	91	182 ~ 183	91	182 ~ 183	91	182 ~ 183	91	182 ~ 183				
		8	80	~ 89		Spectrum	Voice	52	~ 102	80	80 ~ 89	08		80 ~ 89	99	198 ~ 199	99	198 ~ 199	99	198 ~ 199	99	198 ~ 199	99	198 ~ 199	99	198 ~ 199
		7	70	~ 79				40	40 ~ 49	04	40 ~ 49	98		196 ~ 197	98	196 ~ 197	98	196 ~ 197	98	196 ~ 197	98	196 ~ 197	98	196 ~ 197		
		6	60	~ 69				30	30 ~ 39	03	30 ~ 39	97		194 ~ 195	97	194 ~ 195	97	194 ~ 195	97	194 ~ 195	97	194 ~ 195	97	194 ~ 195		
		5	50	~ 59				20	20 ~ 29	02	20 ~ 29	96		192 ~ 193	96	192 ~ 193	96	192 ~ 193	96	192 ~ 193	96	192 ~ 193	96	192 ~ 193		
		4	40	~ 49				10	10 ~ 19	01	10 ~ 19	95		190 ~ 191	95	190 ~ 191	95	190 ~ 191	95	190 ~ 191	95	190 ~ 191	95	190 ~ 191		
		3	0	~ 39				00	0 ~ 9	00	0 ~ 9	94		188 ~ 189	94	188 ~ 189	94	188 ~ 189	94	188 ~ 189	94	188 ~ 189	94	188 ~ 189		
			20	20 ~ 29	02			20 ~ 29	93	186 ~ 187	93	186 ~ 187	93	186 ~ 187	93	186 ~ 187	93	186 ~ 187	93	186 ~ 187						
			10	10 ~ 19	01			10 ~ 19	92	184 ~ 185	92	184 ~ 185	92	184 ~ 185	92	184 ~ 185	92	184 ~ 185	92	184 ~ 185						
			00	0 ~ 9	00	0 ~ 9	91	182 ~ 183	91	182 ~ 183	91	182 ~ 183	91	182 ~ 183	91	182 ~ 183	91	182 ~ 183								
			00	0 ~ 9	00	0 ~ 9	90	180 ~ 181	90	180 ~ 181	90	180 ~ 181	90	180 ~ 181	90	180 ~ 181	90	180 ~ 181								

[Compatible] One to one. (Channel values are incremented by ones.)

Channel	01		02		03		04		05		06	07	08		09		10		11		12		
	Speed		Control Mode		Effect		Effect		Bright. Overall				Bright. CH. R		Bright. CH. G		Bright. CH. B		Bright. CH. W				
	Set	Range	Set	Range	Set	Range	Set	Range	Set	Range			Set	Range	Set	Range	Set	Range	Set	Range	Set	Range	
Position of Push Rod	99	99 ~ 255	Dynamic	Audio	4 ~ 255	90	9 ~ 255	09	9 ~ 255	100	100 ~ 255	100	100 ~ 255	100	100 ~ 255	100	100 ~ 255	100	100 ~ 255	100	100 ~ 255	100	100 ~ 255
	80	80 ~ 98				80	8	08	8	99	99	99	99	99	99	99	99	99	99	99	99		
	50	50 ~ 79		Voice		3	70	7	07	7	98	98	98	98	98	98	98	98	98	98	98	98	
	30	30 ~ 49					60	6	06	6	97	97	97	97	97	97	97	97	97	97	97	97	
	20	20 ~ 29		Spectrum		Audio	2	40	4	04	4	96	96	96	96	96	96	96	96	96	96	96	96
	15	15 ~ 19						30	3	03	3	95	95	95	95	95	95	95	95	95	95	95	95
	12	12 ~ 14	Voice		1	20		2	02	2	:	:	:	:	:	:	:	:	:	:	:	:	
	11	11				10		1	01	1	07	7	07	7	07	7	07	7	07	7	07	7	
	10	10	Normal		0	00		0	00	0	06	6	06	6	06	6	06	6	06	6	06	6	
	9	9				05		5	05	5	05	5	05	5	05	5	05	5	05	5	05	5	
	8	8			04	4	04	4	04	4	04	4	04	4	04	4	04	4	04	4			
	7	7			03	3	03	3	03	3	03	3	03	3	03	3	03	3	03	3			
	6	6			02	2	02	2	02	2	02	2	02	2	02	2	02	2	02	2			
	5	5			01	1	01	1	01	1	01	1	01	1	01	1	01	1	01	1			
	4	4			00	0	00	0	00	0	00	0	00	0	00	0	00	0	00	0			
	3	0 ~ 3																					

If the channel color sequence of luminaires is not R-G-B-W, the brightness channel shall be switched accordingly.

### 6.2.2. THE OTHER EXTERNAL CONTROL

Customers can use serial port instructions to call the effect and speed of the controller through the external control device, support COM protocol, Mod bus protocol.

Please contact us to obtain the COM protocol and Mod bus command protocol.

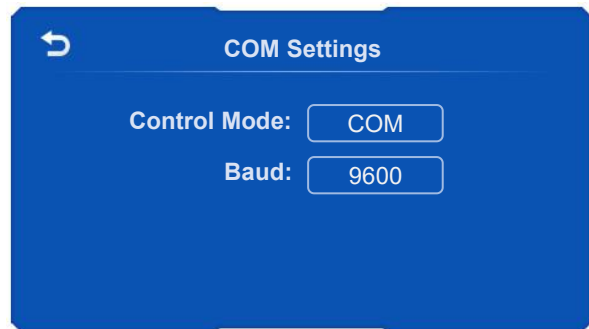
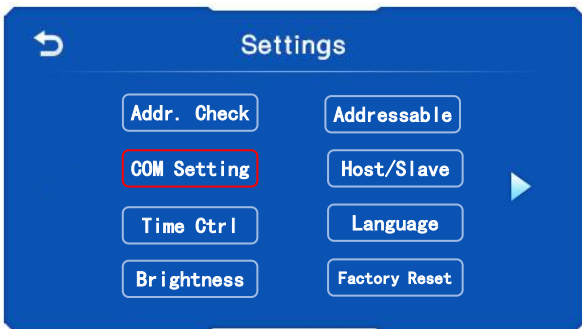

### 6.3. TIME CONTROL

It has time control function. After enabling time control, the specified effect can be triggered in a specified time. Enter "Parameter Setting" - "Time Control" function to enable.

Maximum time control lists of player can be 100, and maximum 10 effects can be set in each list.

Noted: This function only applies to pattern effects.

When a controller is connected to the cloud platform, the time control function applies to the cloud scenario.

In addition, the maximum support is 10 times/scenes \* 10 scenes

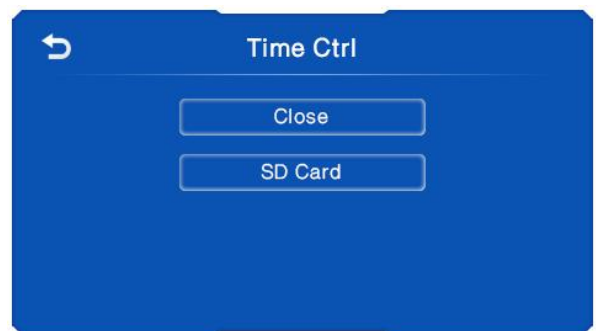

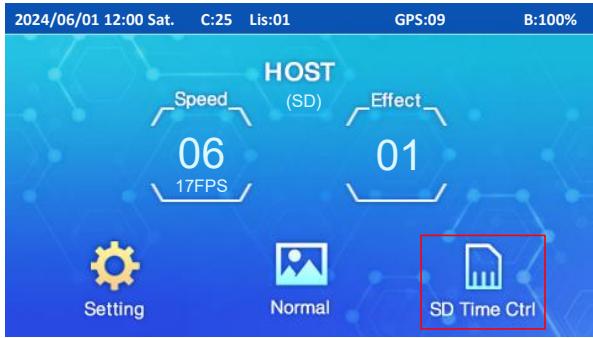
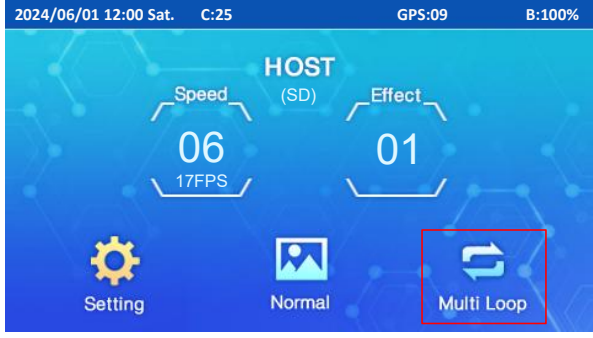
Mode	Description	Shows
SD Card Time Control	The light is black while waiting. The controller will switch to corresponding effect mode when it reaches the time set. (The “Normal” and “Effect” buttons are disabled.)	
Normal	Manually set the time control off, it will become controllable.	

## 7. ADDRESSING

### 7. 1. CHIP SUPPORTED

Chip	Addressing	Custom Channel	Set parameters					
			No signal State	Power-on Setting	Current	Forward	Issue	GAMMA
UCS512A	√	x	x	x	x	x	x	x
UCS512B	√	x	x	x	x	x	x	x
UCS512C0	√	x	x	x	x	x	x	x
UCS512C4	√	x	x	√	x	x	x	x
UCS512CN	√	x	√	√	x	x	x	x
UCS512D	√	x	√	√	√	x	x	x
UCS512E0	√	√	√	√	√	√	x	x
UCS512G4	√	x	x	x	x	x	x	x
UCS512G6	√	x	x	x	x	x	x	x
UCS512KH	√	√	x	x	x	x	x	x
UCS512KL	√	√	x	x	x	x	x	x
UCS512HL	√	x	x	x	x	x	x	x
UCS512H3L	√	x	x	x	x	x	x	x
UCS512H4	√	x	x	x	x	x	x	x
UCS512H4L	√	x	x	x	x	x	x	x
UCS512H5L	√	x	x	x	x	x	x	x
DMX512AP	√	x	x	x	x	x	x	x
SM16511	√	x	x	x	x	x	x	x
SM16512	√	x	x	x	x	x	x	x
SM16520	√	x	x	x	x	x	x	x
SM16500	√	x	√	√	x	x	x	x

Chip	Addressing	Custom Channel	Set parameters					
			No signal State	Power-on Setting	Current	Forward	Issue	GAMMA
SM17500	√	√	√	√	√	x	x	x
SM17512	√	x	√	√	√	x	x	x
SM17522	√	x	√	√	√	x	x	x
SM18522P	√	x	√	√	√	x	x	x
SM18522PH	√	x	√	√	√	x	x	x
SW-D	√	x	x	x	x	x	x	x
Hi512A0	√	√	x	x	x	x	x	x
Hi512A4	√	x	√	√	x	x	x	x
Hi512A6	√	x	√	√	x	x	x	x
Hi512D	√	x	√	√	√	x	x	x
TM512AB3	√	x	x	x	x	x	x	x
TM512AL1	√	x	x	x	x	x	x	x
TM512ACx	√	x	x	x	x	x	x	x
TM512AD	√	x	√	√	√	x	x	x
QED512P	√	x	√	√	√	x	x	x
GS8511	√	x	x	x	x	x	x	x
GS8512	√	x	x	x	x	x	x	x
GS8513	√	x	x	x	√	x	x	x
GS8515	√	x	x	x	√	x	x	x
GS8523	√	x	√	√	√	x	√	x
GS8524	√	x	√	√	√	x	√	x
GS8525	√	x	√	√	√	x	√	x
GS8526	√	x	√	√	√	x	√	x

## 7. 2. SUCCESSFULLY ADDRESSED AND SET PARAMETERS

Chip	Lighting color after power on	Addressed		Byte + No signal + No signal		Current parameter		Self-Channel Setting	
		First chip	Other chip	First chip	Other chip	First chip	Other chip	First chip	Other chip
UCS512A	White	Blue	Blue	-	-	-	-	-	-
UCS512A1	White	Blue	Blue	-	-	-	-	-	-
UCS512A2	White	Blue	Blue	-	-	-	-	-	-
UCS512B3	White	Blue	Blue	-	-	-	-	-	-
UCS512C	Custom	White	White	-	-	-	-	-	-
UCS512C0	-	White	White	-	-	-	-	-	-
UCS512C3	Custom	White	White	Red	Red	-	-	-	-
UCS512C4	Custom	White	White	Red	Red	-	-	-	-
UCS512CN	Custom	Yellow	White	Yellow	Power on	-	-	-	-
UCS512D	Custom	Yellow	White	Yellow	Power on	Yellow	Red	-	-
UCS512E0	Custom	Yellow	White	Yellow	Power on	-	-	Yellow	Green
UCS512EH	Custom	Yellow	White	Yellow	Power on	Yellow	Red	Yellow	Green
UCS512G4	Custom	Yellow	White	White (Or custom)	White (Or custom)	White	White	-	-
UCS512G6	Custom	Yellow (Or custom)	White (Or custom)	White (Or custom)	White (Or custom)	White	White	-	-
DMX512AP	-	White	White	-	-	-	-	-	-
SM16512	-	Green	Green	-	-	-	-	-	-

Chip	Lighting color after power on	Addressed		Byte + No signal + No signal		Current parameter		Self-Channel Setting	
		First chip	Other chip	First chip	Other chip	First chip	Other chip	First chip	Other chip
SM16511	-	Green	Green	-	-	-	-	-	-
SM16520	-	Green	Green	-	-	-	-	-	-
SM16500	Custom	Red	Green	Red	Power on	-	-	-	-
SM17500	Custom	Red	Green	Red	Power on	Red	Yellow	Red	Purple
SM17512	Custom	Red	Green	Blue	Blue	-	-	-	-
SM17522	-	Red	Green	Red	Blue	Red	Yellow	-	-
SM18522	Custom	Red	Green	Blue	Blue	-	-	-	-
SM18522PH	-	Red	Green	Red	Blue	Red	Yellow	-	-
SW-D	-	Yellow	Green	-	-	-	-	-	-
Hi512A4	Custom	Red	Green	Red_	Green	-	-	-	-
Hi512A6	Custom	Red	Green	Red	Green	-	-	-	-
Hi512A0	-	White	White	White	White	-	-	-	-
Hi512D	-	Red	Green	Green	Green	Green	Green	-	-
Hi512E	-	Red	Green	Green	Green	Green	Green	-	-
TM512AB3	White	Blue	Blue	-	-	-	-	-	-
TM512AL1	White	Blue	Blue	-	-	-	-	-	-
TM512AC0	-	White	White	-	-	-	-	-	-
TM512AC2	Custom	White	White	-	-	-	-	-	-
TM512AC3	Blue	White	White	-	-	-	-	-	-
TM512AC4	Blue	White	White	-	-	-	-	-	-
TM512AD	Blue	Yellow	White	Yellow	Power on	Yellow	Red	-	-
GS8512	Custom	Red	Cyan	-	-	-	-	-	-
GS8513	Red+Cyan	Red	Cyan	-	-	-	-	-	-
GS8515	Red+Cyan	Red	Cyan	-	-	-	-	-	-
GS8523	-	Red	Cyan	-	-	-	-	-	-
GS8524	-	Red	Cyan	-	-	-	-	-	-
GS8525	-	Red	Cyan	-	-	-	-	-	-
GS8526	-	Red	Cyan	Red	Cyan	-	-	-	-

### 7. 3. ADDRESSABLE OPERATION

Option	Setting	Instructions																
Chip	<table border="1"> <thead> <tr> <th colspan="2">Chip select</th> </tr> </thead> <tbody> <tr> <td>P 1</td> <td>SW-D DMX512AP UCS512A UCS512B UCS512C0 UCS512C4 UCS512D UCS512E-SELF</td> </tr> <tr> <td>P 2</td> <td>SM16500 SM16511 SM16512 SM16520 SM17512 SM17522 SM17500-NOR SM17500-SELF</td> </tr> <tr> <td>P 3</td> <td>HI512A0-NOR TM512AB3 H512A0-SELF TM512ACX HI512A4 TM512AD HI512A6 TM512AL1</td> </tr> <tr> <td>P 4</td> <td>QED512P GS8511 HI512D GS8512/3/5 UCS512C/CN GS8526/6 HI512E GS8525</td> </tr> <tr> <td>P 5</td> <td>SM18522P UCS512G/H/K SM18522PH UCS512K-SELF UCS512C1/2 UCS512G6</td> </tr> </tbody> </table>	Chip select		P 1	SW-D DMX512AP UCS512A UCS512B UCS512C0 UCS512C4 UCS512D UCS512E-SELF	P 2	SM16500 SM16511 SM16512 SM16520 SM17512 SM17522 SM17500-NOR SM17500-SELF	P 3	HI512A0-NOR TM512AB3 H512A0-SELF TM512ACX HI512A4 TM512AD HI512A6 TM512AL1	P 4	QED512P GS8511 HI512D GS8512/3/5 UCS512C/CN GS8526/6 HI512E GS8525	P 5	SM18522P UCS512G/H/K SM18522PH UCS512K-SELF UCS512C1/2 UCS512G6	Select the chip of luminaire.				
Chip select																		
P 1	SW-D DMX512AP UCS512A UCS512B UCS512C0 UCS512C4 UCS512D UCS512E-SELF																	
P 2	SM16500 SM16511 SM16512 SM16520 SM17512 SM17522 SM17500-NOR SM17500-SELF																	
P 3	HI512A0-NOR TM512AB3 H512A0-SELF TM512ACX HI512A4 TM512AD HI512A6 TM512AL1																	
P 4	QED512P GS8511 HI512D GS8512/3/5 UCS512C/CN GS8526/6 HI512E GS8525																	
P 5	SM18522P UCS512G/H/K SM18522PH UCS512K-SELF UCS512C1/2 UCS512G6																	
Pixels	<table border="1"> <thead> <tr> <th colspan="2">Pixels</th> </tr> </thead> <tbody> <tr> <td>◀</td> <td>1 ▶</td> </tr> </tbody> </table>	Pixels		◀	1 ▶	Set the pixel of a DMX512 chip. Select ◀ ▶ to set value.												
Pixels																		
◀	1 ▶																	
Channels	/	According to the lighting Settings, select monochrome, two/three/four-color options.																
Start Chip	<table border="1"> <thead> <tr> <th colspan="4">Start Chip</th> </tr> </thead> <tbody> <tr> <td>▲</td> <td>▲</td> <td>▲</td> <td>▲</td> </tr> <tr> <td>0</td> <td>0</td> <td>0</td> <td>1</td> </tr> <tr> <td>▼</td> <td>▼</td> <td>▼</td> <td>▼</td> </tr> </tbody> </table>	Start Chip				▲	▲	▲	▲	0	0	0	1	▼	▼	▼	▼	Addressing the Nth luminaire. Select ▼ ▲ to set value.
Start Chip																		
▲	▲	▲	▲															
0	0	0	1															
▼	▼	▼	▼															
Controller	<table border="1"> <thead> <tr> <th colspan="3">Controller ID</th> </tr> </thead> <tbody> <tr> <td>▲</td> <td>▲</td> <td>▲</td> </tr> <tr> <td>0</td> <td>0</td> <td>1</td> </tr> <tr> <td>▼</td> <td>▼</td> <td>▼</td> </tr> </tbody> </table> All <input type="checkbox"/>	Controller ID			▲	▲	▲	0	0	1	▼	▼	▼	Set the ID of EN controller which need to address luminaire.				
Controller ID																		
▲	▲	▲																
0	0	1																
▼	▼	▼																
Ports	All	Set the port of EN controller which need to address luminaire.																
Start Addr.	<table border="1"> <thead> <tr> <th colspan="4">Starting address</th> </tr> </thead> <tbody> <tr> <td>▲</td> <td>▲</td> <td>▲</td> <td>▲</td> </tr> <tr> <td>0</td> <td>0</td> <td>0</td> <td>1</td> </tr> <tr> <td>▼</td> <td>▼</td> <td>▼</td> <td>▼</td> </tr> </tbody> </table>	Starting address				▲	▲	▲	▲	0	0	0	1	▼	▼	▼	▼	It can be calculated automatically according to the number of luminaires, dots and lights. Manual setting is also supported. Select ▼ ▲ to set value.
Starting address																		
▲	▲	▲	▲															
0	0	0	1															
▼	▼	▼	▼															
Increment	/	It can be calculated automatically according to the number of luminaires, dots and lights. Manual setting is not supported.																
Check	/	Select and enter the addressing check interface.																
Start	/	Select to start addressing the luminaire.																

E.g. Addressing the second 8 pixels/meter luminaire with 4-channels UCS512C0 chip.

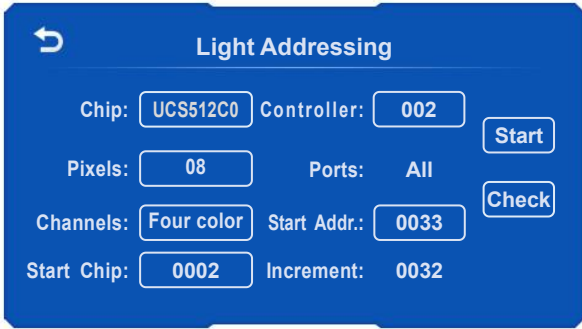

### 7. 4. RE-ADDRESSING

Select and addressing the luminaire again according to the addressable setting.

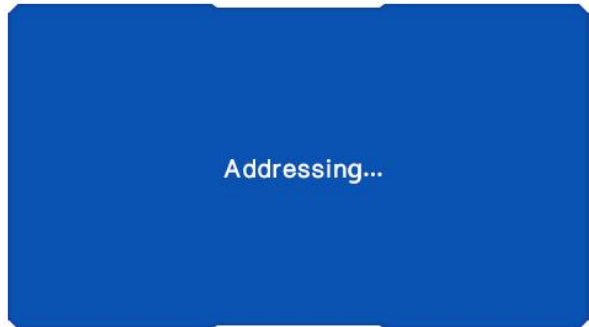
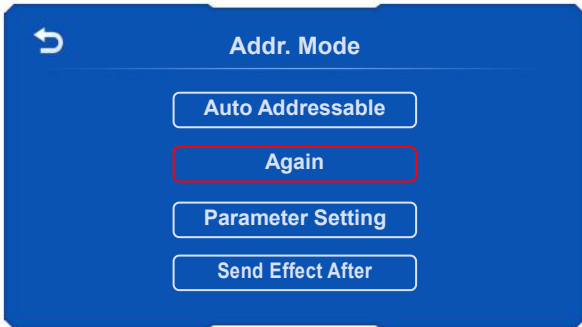

### 7. 5. PARAMETER SETTINGS

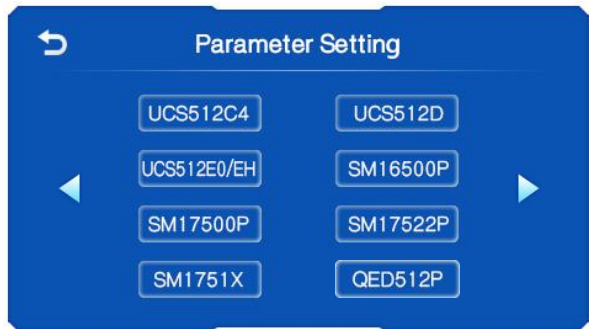
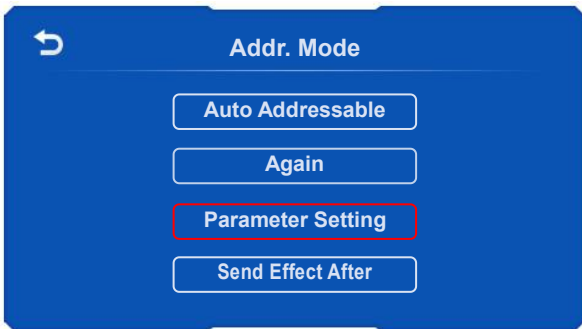

The option is invalid if the chip does not supported.

	Interface	Introduction
Page 1	Red: 255      Green: 255 Blue: 255      White: 255 Byte Select: 4 No Signal: Last Frame <input type="button" value="Write"/>	Color RGBW: Select to set RGBW gray. Byte Select: Select to set channel of chip. No signal: Last Frame: The luminaire stays the last frame color. Power on effect: The luminaire stays the color power-on.
Page 2	Red: 15      Green: 15 Blue: 15      White: 15 Gain Mode: Null Chip Type: Other <input type="button" value="Write"/>	Current RGBW: Select to set the current of RGBW. Gain Mode: Select and select the current gain level. It is only for SM17500. Chip Type: Select and select the type of forward chip.

Interface		Introduction
Page 3	<div style="border: 1px solid black; padding: 5px;"> <p>Forward Times:                      Protocol: Zero Code</p> <p>Auto addressing:</p> <p>Step:                                      <input type="button" value="Write"/></p> <p style="text-align: center;"><input type="button" value="Self-Channel Setting"/></p> </div>	<p>Forward Times: Select and set forward time.</p> <p>Protocol: Select and set forward protocol (zero code / DMX).</p> <p>Auto addressing: Select and set whether to turn on the step setting.</p> <p>Step: Select and set the step value. It is only for SM17522P.</p> <p>Self-Chan Setting: Select to enter the Self-Channel setting interface.</p> <p>Write: Select to set parameter into the luminaire.</p>

## 7. 6. SEND THE SPECIFIED EFFECT AFTER ADDRESSING

Setting this effect before addressing is convenient to check whether the address cable between two luminaires are disconnected and the address value cannot be written correctly.

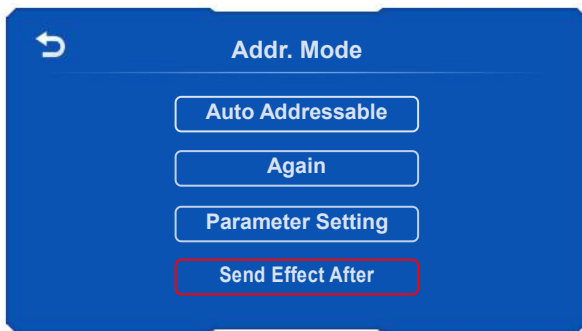

When this option is enabled, the luminaire lights up after the address is written: the chip at address 1 lights up red and the rest of the addresses light up white.

## 7. 7. ADDRESSING IN LED PLAYER

Correct access to controllers and open LED Player. Click the “Address” of “Debug”, and pop the window.

**Note:** If the controller is offline, there is a probability that the address data cannot be saved successfully.

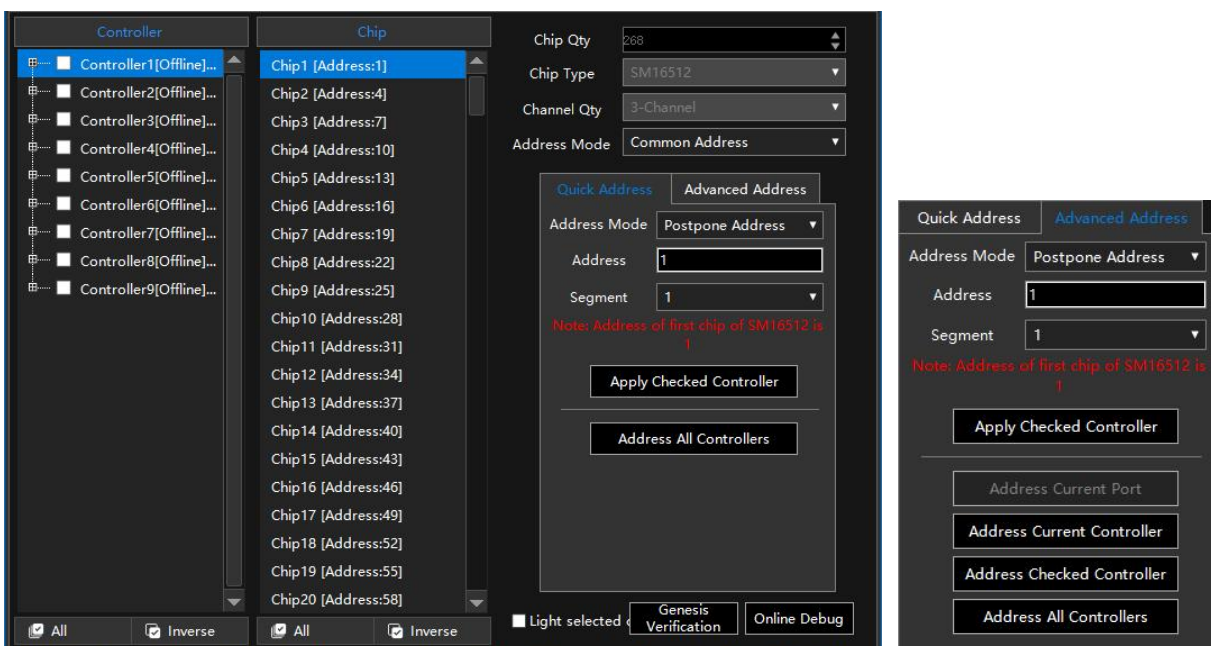

Controllers	Controller	It shows the number of controllers in the project automatically. [Online] is that the controllers connecting properly. [Offline] is that the controllers cannot address the luminaire. If the chip is not DMX series, the addressing interface becomes unavailable. It can be modified in SETTINGS.
	The gray chip	The chip will not be able to set, if its address is outside the actual routing address of the project.
	Chip	It shows the number/address of chip.
	Online Debug	Click to jump into Online Debugging interface.
Parameter	Chip Qty	It will be the number of driving pixels set in LED Player “Settings” while first be used.
	Chip Type	It will be the chip type set in LED Player “Settings” while first be used.
	Channel Qty	Number of chip channels.
	Address Option	Quick Address and Advanced Address.
	Address Mode	None, Address extension, Use the same address.  None: It only saves the address of selected chip. And the others will not changed.  Address Extension: It only saves the address of the selected chip. And the others will be extended.  Use The Same Address: It saves the same address of all chips.
	Address	set the address of selected chip, and click Save.
	Segment	Set the pixel of selected chip, and click Save.
	Address option	Quick Address
Advanced Address		Apply Checked Controller: Click and save the chip data of all checked controllers.  Address Current Port: Click and address the chips of selected port. Address Current Controller: Click and address the chips of selected controller. Address Checked Controller: Click and address the chips of all checked controllers.  Address All Controllers: Click and address all chips.
Light -up	Click it and light up the selected chip. Please make sure the address of chips in LED Player are same with the luminaires’.	
Address	LED Player shows the progress bar in the lower right corner. It shows “Addressing completed!” when the EN controller receives the addressing data. It is not the luminaires addressing correct. The addressing successful is according to the light color.	

## 7. 8. ADDRESSING CHECK

Enter addressing check interface as below.

Step 1: Select Addr. Check of Setting.



Step 2: Select the Check of Addressable.



Option	Interface 3	Introduction																
Increment	<table border="1"> <thead> <tr> <th colspan="4">Increment</th> </tr> </thead> <tbody> <tr> <td>▲</td> <td>▲</td> <td>▲</td> <td>▲</td> </tr> <tr> <td>0</td> <td>0</td> <td>0</td> <td>1</td> </tr> <tr> <td>▼</td> <td>▼</td> <td>▼</td> <td>▼</td> </tr> </tbody> </table>	Increment				▲	▲	▲	▲	0	0	0	1	▼	▼	▼	▼	<p>Set the total number of channels for each DMX512 chip.</p> <p>Select ▼ / ▲ to set value.</p>
Increment																		
▲	▲	▲	▲															
0	0	0	1															
▼	▼	▼	▼															
Current LEDS	<table border="1"> <thead> <tr> <th colspan="4">Current LEDS</th> </tr> </thead> <tbody> <tr> <td>▲</td> <td>▲</td> <td>▲</td> <td>▲</td> </tr> <tr> <td>0</td> <td>0</td> <td>0</td> <td>1</td> </tr> <tr> <td>▼</td> <td>▼</td> <td>▼</td> <td>▼</td> </tr> </tbody> </table>	Current LEDS				▲	▲	▲	▲	0	0	0	1	▼	▼	▼	▼	<p>Select ▼ / ▲ to set the value of luminaire.</p>
Current LEDS																		
▲	▲	▲	▲															
0	0	0	1															
▼	▼	▼	▼															
Check Mode	/	<p>Point: Turn on designated luminaire.</p> <p>Pile up: Turn on designated luminaire and all the ones in front of it .</p>																

E.g. Address the 10th 12 pixels/meter luminaire with 3-channels UCS512C0 chip.

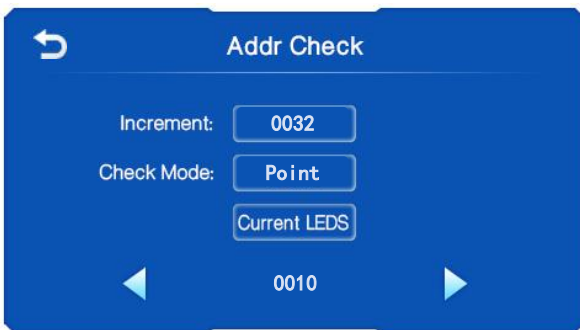

## 7.9. QUICKLY CONFIGURE LUMINAIRE PARAMETERS

### 7.9.1. SET THE ADDRESS PARAMETERS BY PLAYER

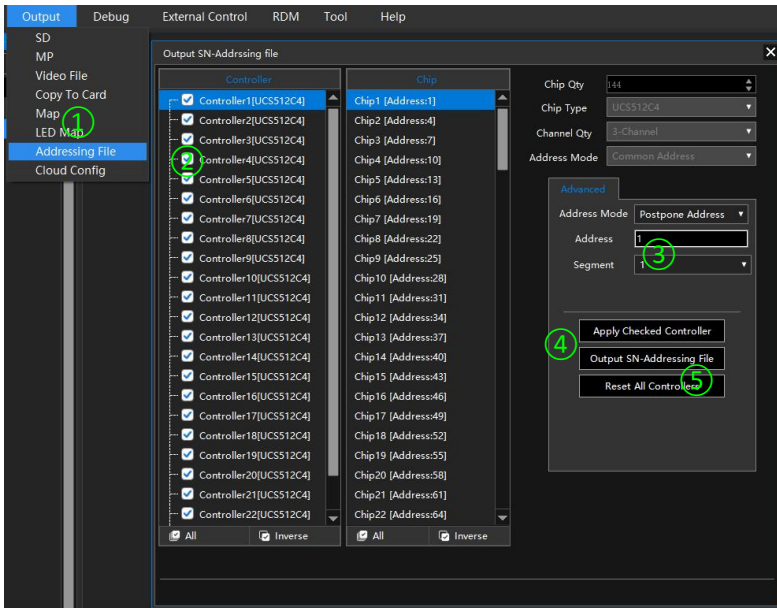

- ① Click “Addressing File” in “Output” to open the setting window.
- ② Check the controllers.
- ③ Set the address and Segment.
- ④ Click “Apply Checked Controller” to save.
- ⑤ Click “Output SN Addressing File”.
- ⑥ Input the SD card and copy the file.

Note: When each controller drives a variety of chips, it should set the chip in “Hardware Settings”.

### 7.9.2. SET PARAMETERS OF DMX CHIP BY PLAYER

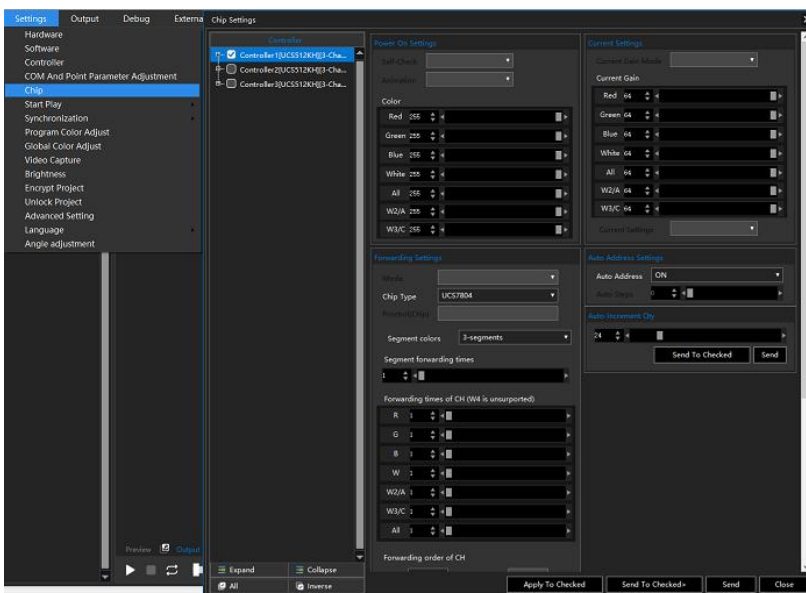

- ① Click “Chip” in “Settings” to open the Chip Settings window.
- ② Check the controllers.
- ③ Set the other parameters of DMX chip, such as channel gray value when powered on and the channel color without control signal.
- ④ Click “Apply To Checked” to save.
- ⑤ Click “Close” .
- ⑥ Referring to Outputting SD Files, select Parameter Settings of the chip in the pop-up window to export the SD card files and copy them to the SD card. Then you can set the parameters of the lamp in the setting interface of the controller.

### 7.9.3. ADDRESS OPERATION ON CONTROLLER

1. Insert the SD card with the Write File into the controller, and power on the controller.
2. Select "Address Lights" in the Quick Config. It shows "Light address configuring..." in the LCD screen and sends the address parameter to luminaire.

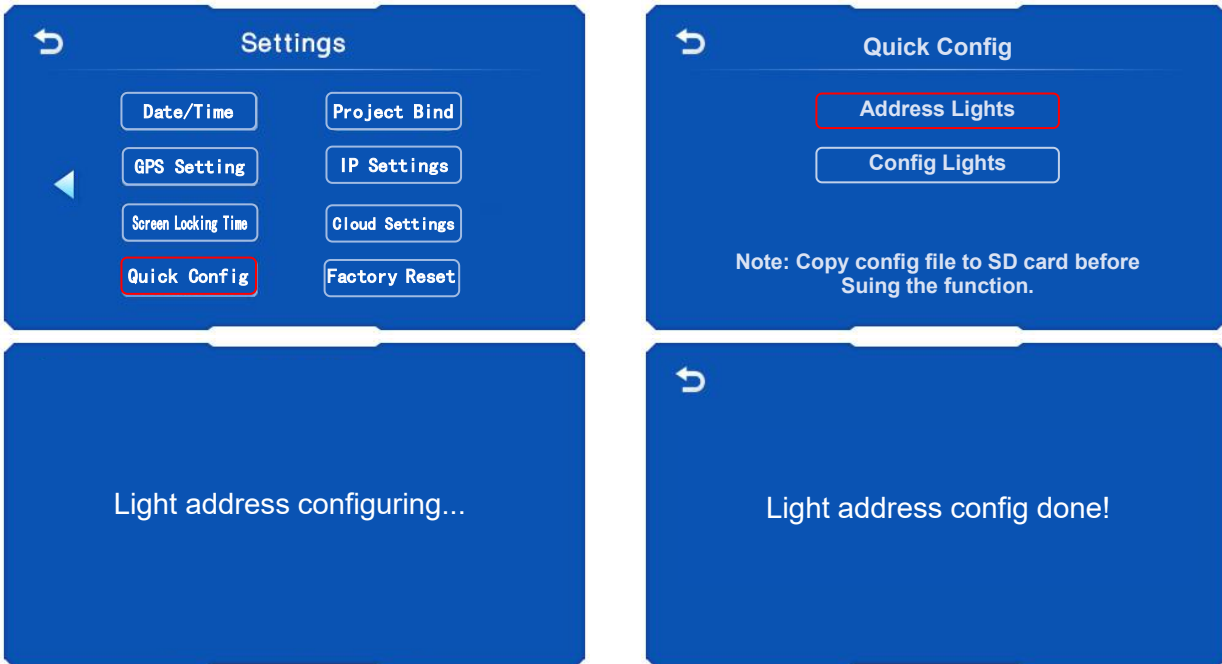

Note, Whether the luminaire addressed is correct needs to be judged according to color of lighting up.

### 7.9.4. SETTING PARAMETERS ON CONTROLLER

1. Insert the SD card with the chip parameters into the controller, and power on the controller.
2. Select "Config Lights" in the Quick Config. It shows "Light param configuring..." in the LCD screen and sends the address parameter to luminaire.

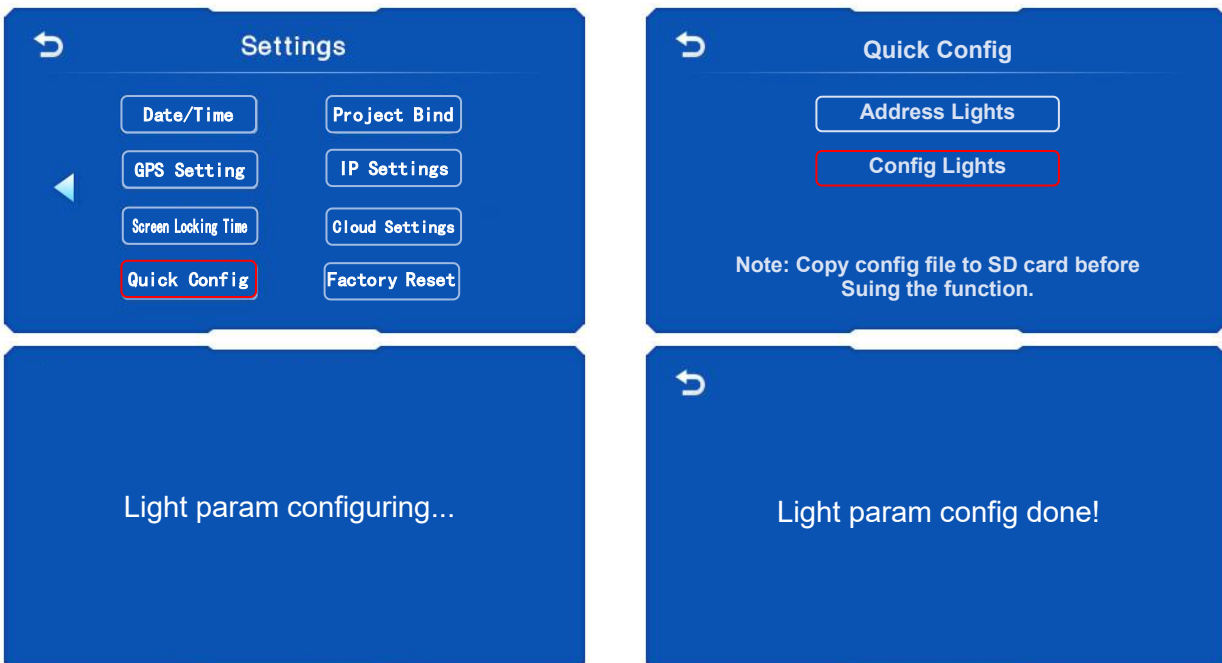

Note, Whether the luminaire addressed is correct needs to be judged according to color of lighting up.

## 8. REMOTE OPERATION OF CLOUD CONTROL SYSTEM

The designated SN controller has built-in 4G card. The correct access to our cloud platform can realize the functions of remote setup, address writing, debugging and verification.

### 8.1. GETTING THE DEVICE CODE

Click Project Bind of Settings menu to get the device code.

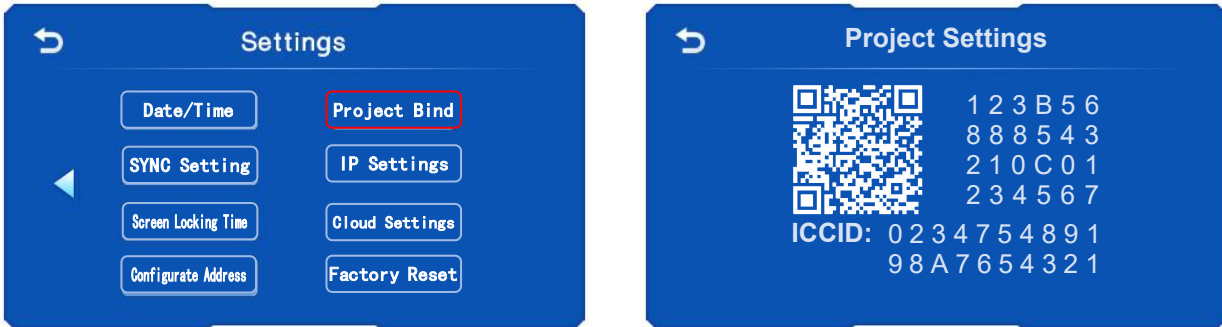

### 8.2. SETTING BY CLOUD SERVER OF WEBSITE

#### 8.2.1. ACCESS STEPS ON WEBSITE

The Cloud server Web site: <https://cloud-3.seekway.cn>

Click the [+ Device] in the [Group management]. Enter the 24 characters in the ID bar and click [Confirm]

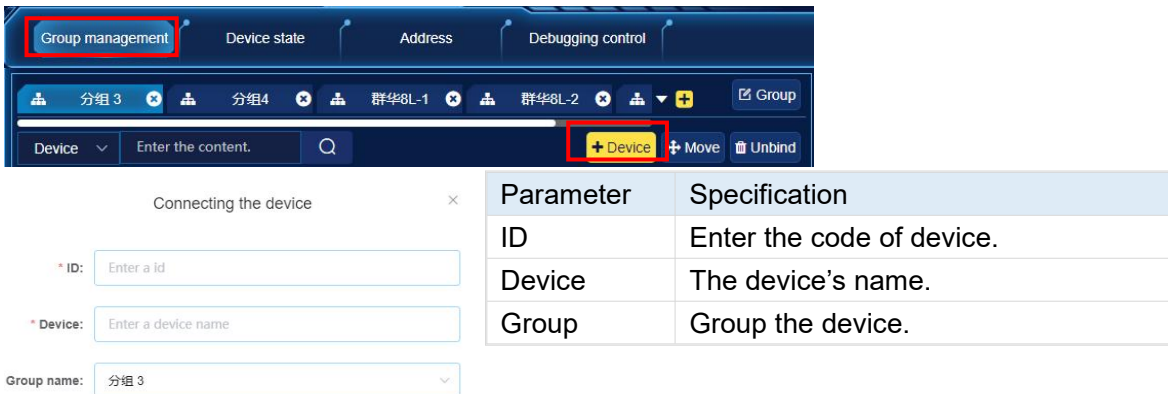

At the same time, ensure that the Cloud Settings under Cloud Settings of the SN controller is in the "ON" state.

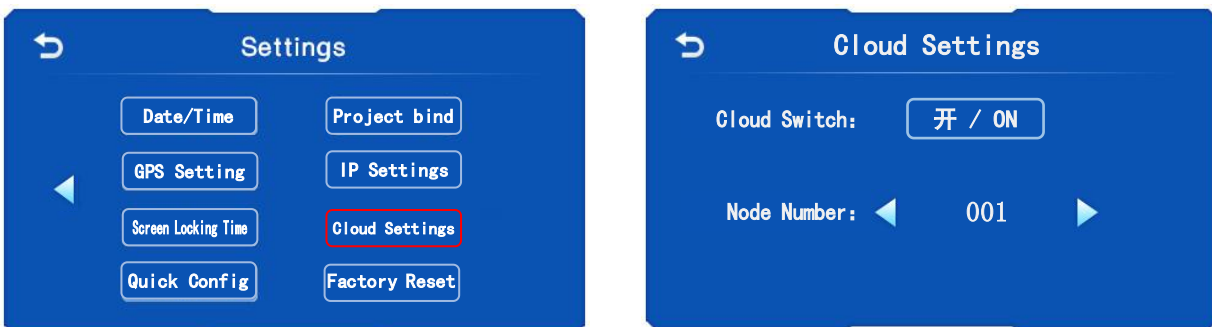

### 8.2.2. SET THE STATE BY CLOUD SERVER ON WEBSITE

After the controller is connected to the cloud platform, under the "\*\*\* Grouping" (such as project A) interface of "Node Status", check a controller (multiple selection supported) to remotely set the speed, brightness, animation, etc.,

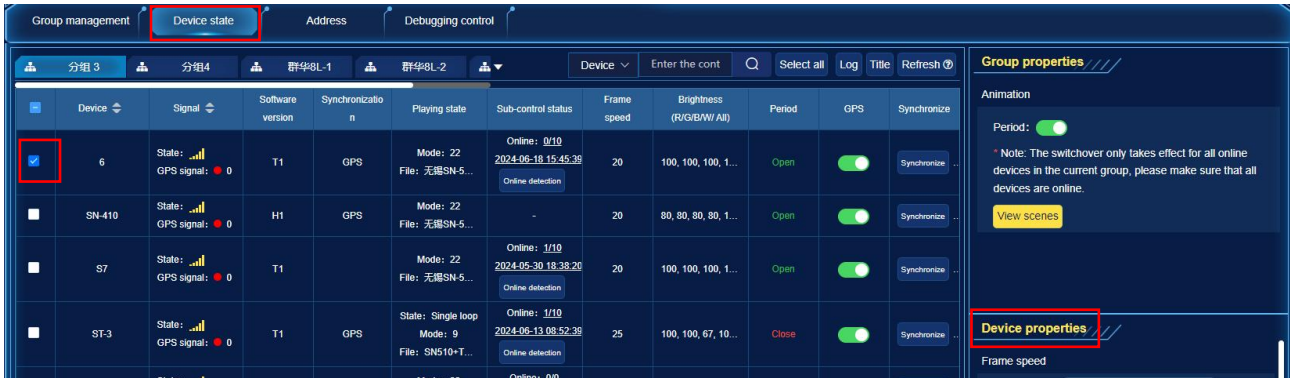

If we need to test the sub-controller, you can click "Online detection" on this interface to obtain the sub-controller number and on-line statue. The slave of the SN controller must also be connected to the cloud platform to detect the sub-controller information of the slave.

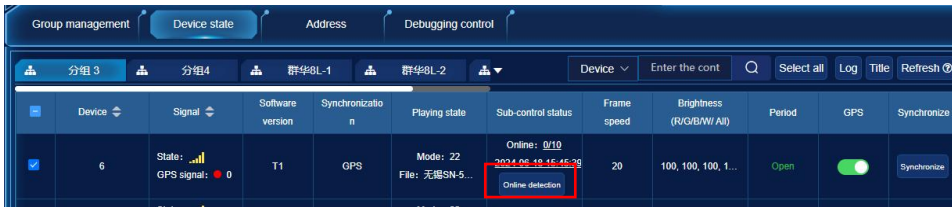

### 8.2.3. ADDRESSING AND VERIFY LUMINAIRE BY CLOUD SERVER ON WEBSITE

1. Check the node in the Group \* of "Address" (multiple selection supported) to address it has drove the controllers. After the address is complete, the Address Succeeded message is displayed on the node list. **The actual addressing success depends on the luminaire effect.**

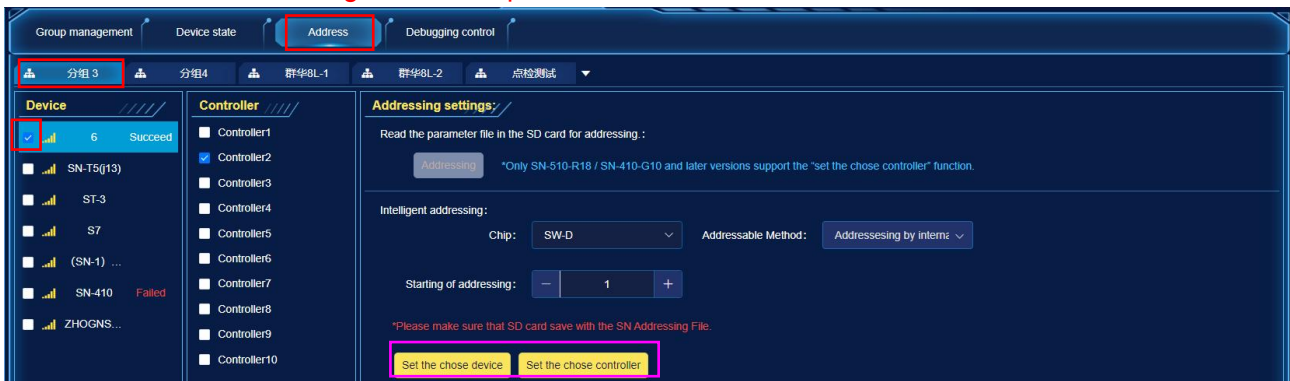

2. Check the node in the Group \* of "Debugging control" (multiple selection supported) to debug.



3. When the cloud platform set addresses / debug, the controller enters the corresponding function display interface.

## 8.2.4. CLOUD UPDATE ANIMATION FILE

In addition to remotely switching animations on the cloud platform, SN-510P can also upload and update animation files through the cloud platform for remote replacement of SD card effect files.

The cloud update animation file is divided into two processes: download and decompression. Download speed is about 30KB/s, and decompression speed is about 2.5MB/s.

It takes about 1 hour to update every 100M "\*" ".gz" files.

Notes,

- 1) When updating the animation in the standalone state of the SN controller, first issue a one second black screen command and then do not output the control light signal. To maintain the control of the lighting fixtures, it is necessary to click "Pause Update" before or during the update, connect the SN controller to the computer (start the LED Player), and then start updating the animation files.
- 2) Synchronous update of one-key Addressing files is not currently supported.
- 3) When the master and slave SN controllers are cascaded, the cloud update effect requires both the master and slave SN controllers to access the cloud platform.

### 8.2.4.1. OUTPUT THE ANIMATION FILE IN LED Player

Open LED Player and click "Cloud Animation Gzip" of "Output" in the menu bar. In the pop-up window interface, select the animation material to be output and click [Output] to output.

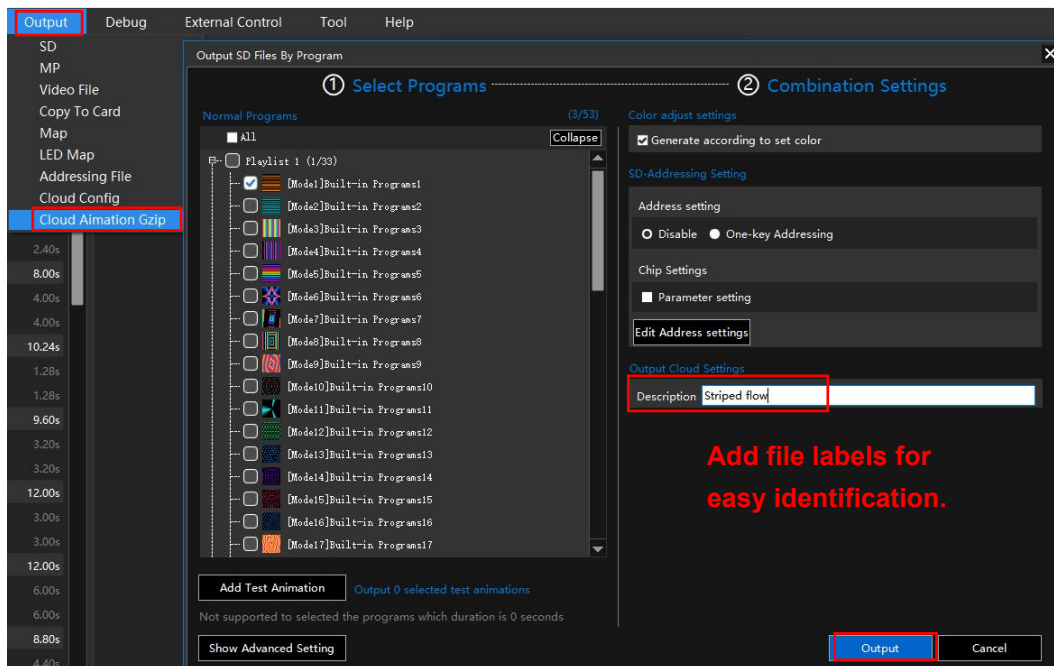

The output effect file is stored in the CloudSD folder under the root directory of the current project. The default file name is SN\*.bin.gz. And it can be changed twice. (Retain the ".gz" test.)

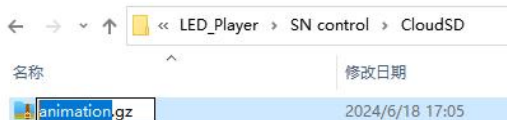

### 8.2.4.2. UPLOAD THE .GZ FILE

On the "SN Series" screen of "Scenario", select the corresponding packet device and click "Upload". In the pop-up window, add (or drag) the file that needs to be updated for uploading.



After the upload is complete, the newly uploaded effect file can be seen on the interface (identified by the file name, effect data, and upload time).

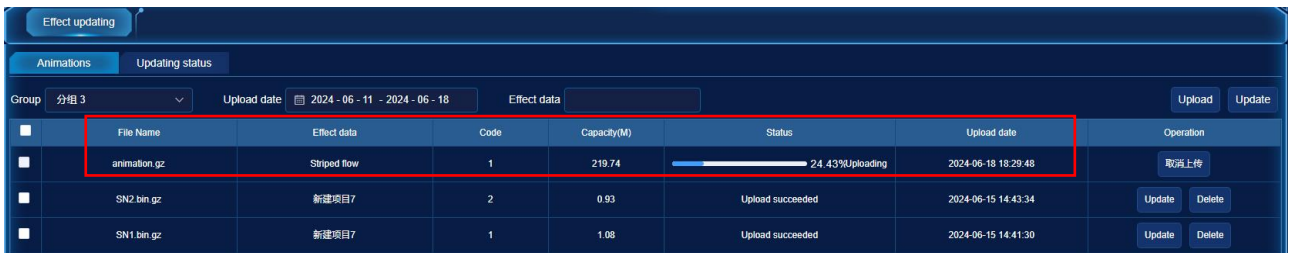

### 8.2.4.3. SET THE NODE CODE OF SN CONTROLLER (REQUIRED).

Before updating the animation file, ensure that the device code (also called node code) of each SN controller has been assigned to download the animation file correctly. If it has been allocated, it does not need to be allocated again.

The assignment operation is as follows.

Method 1, Under "Group management" - "\*\*\* Group" (such as project A), click next to "Code" and enter the editing state. Enter the corresponding value and click to save. When all Settings are complete, click to exit editing state.



Method 2, Select and open "Cloud Settings" in "Settings" to set the device code (node code) on the interface, and the setting takes effect.

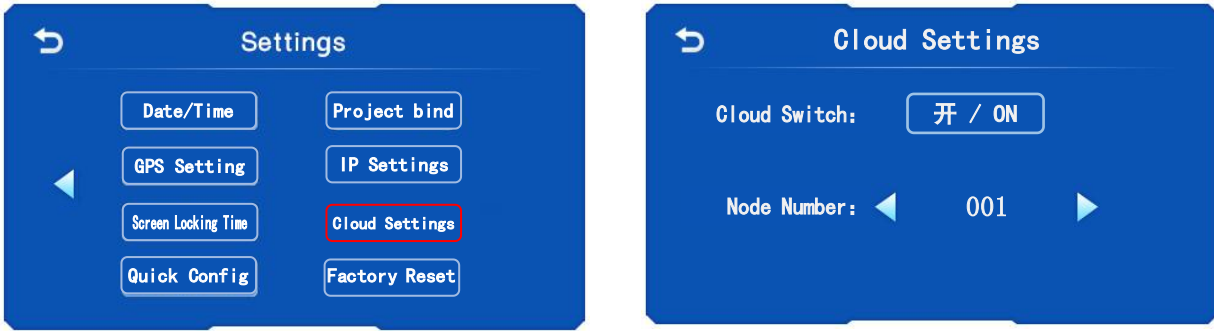

#### 8.2.4.4. DOWNLOAD THE UPDATE FILE TO THE SN CONTROLLER

In the Animations interface of "Program editor", select the corresponding group and click "Update" (multiple selection + simultaneous update is supported).

All SN controller matching the updated file node code (device code) will update the file.

1. The node code of the SN controller must be consistent with the node code of the animation file assigned by the LED Player to ensure the correct update.
2. The online SN controller will immediately execute the file update command, and the offline device will be updated the next time it is online.
3. The download effect process needs to be temporarily interrupted, we can press pause first (do not power off), and continue to download after completing other operations.  
During the download process, the controller is disconnected from the network. That is, it needs to wait for the next power on the network to connect to the cloud, and automatically updates from the beginning.
4. If an error message is displayed in Update Status, check the network status.



We can view the update details on the Update Status page.

设备名称	设备ID	连接状态	效果内容	更新状态	操作	实际更新时间
6	34002B001051323531343636	在线	无耀SN-510云控版本测试_22mode	完成	-	2024-06-17 11:26:32
SN-410	2A0034000C51333133333732	在线	无耀SN-510云控版本测试_22mode	完成	-	2024-06-17 11:26:31
S7	27001A000251303337333232	离线	无耀SN-510云控版本测试_22mode	完成	-	2024-06-17 11:26:31
ST-3	34002C001051323531343636	在线	无耀SN-510云控版本测试_22mode	完成	-	2024-06-17 11:26:31

### 8.2.5. COMPILING A CLOUD SCENARIO (TIME CONTROL)

The SN-510P can set the scene (time control list) on the cloud platform and deliver it to the controller.

1. On the Scene Orchestration page, click [+New], enter the scene name and effective date in the pop-up window, and click [Next].

Note: Each SN controller only supports 10 scene programs, the excess cannot be added again.

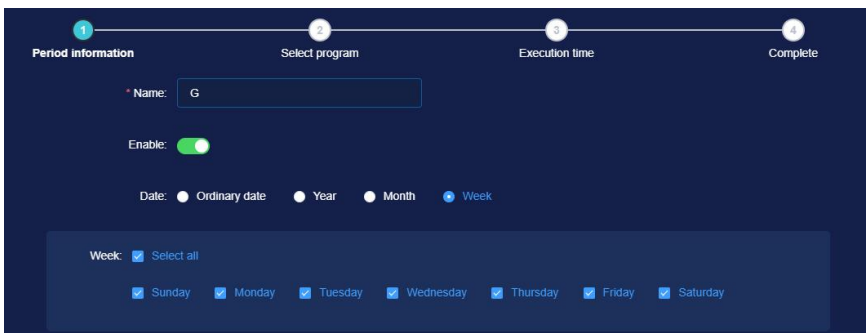
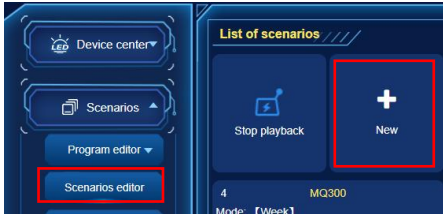

In the existing scene card, we can click [+ Add program] to add twice.

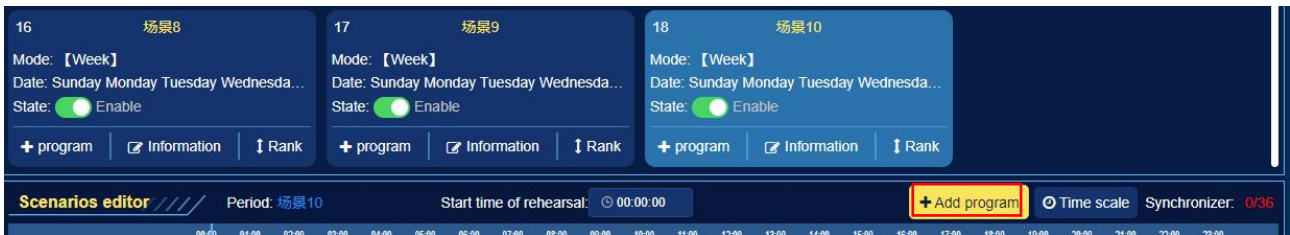

2. Set the name of the time control list and related programs, click [Next].

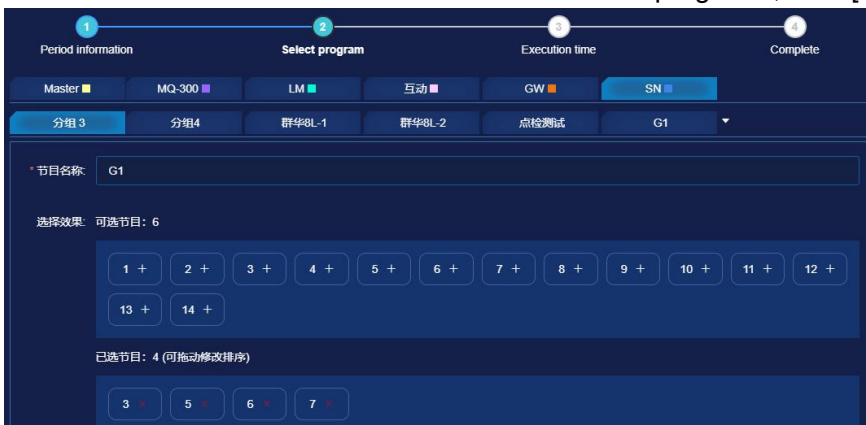

3. Set the playback time and click [Preserve].

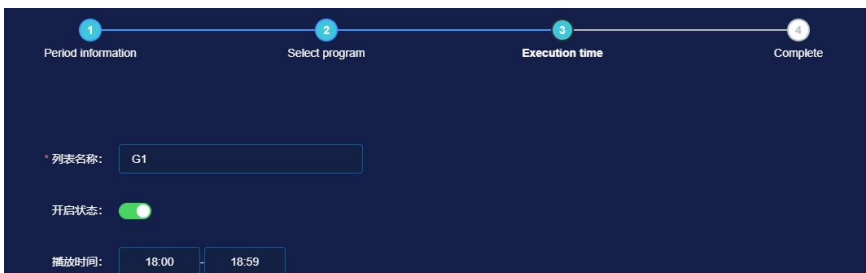



## 8. 3. SETTING BY CLOUD SERVER OF PHONE

### 8. 3. 1. ACCESS STEPS ON THE PHONE

Use your mobile phone to log in to the operation interface.

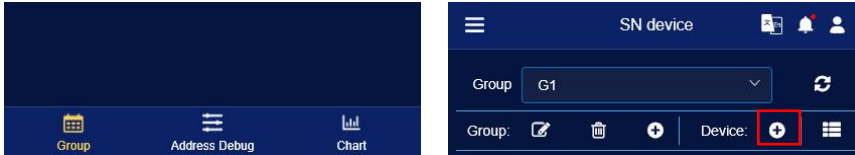
Select "SN device" of "Device center". And then select "+" in the "Group" .



Select the icon  to scan the **ICCID** code in the controller and select "Confirm".

Connecting the device ×

\* ID:  

\* Device:

Group name:

### 8. 3. 2. SETING AND ADDRESSING BY CLOUD SERVER ON PHONE

After the controller is connected to the cloud platform, under the "\*\*\* Grouping" (such as project A) interface of "Address Debug", check a controller (multiple selection supported) to remotely set the speed, brightness, animation, etc.

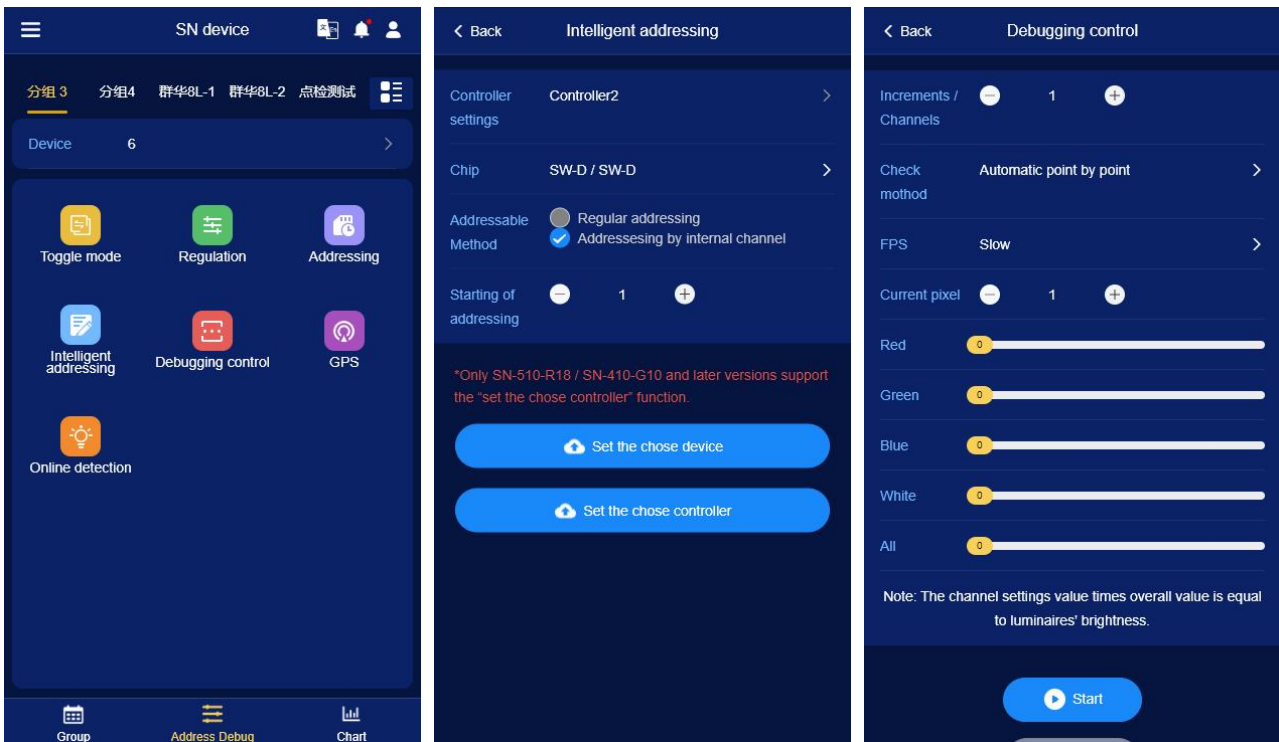

Parameter	Specification
Toggle mode	Select the animation to play. (Single loop, Full loop and random can be selected.) When playing a single loop, you can click to select any effect to play. When Period is enabled, effects cannot be selected for playback.
Regulation	帧速, Set the number of frames per second (FPS) to play, ranging from 0.5 to 33 frames per second.

Parameter	Specification
	亮度, The values range from 0-100, where 100 is the brightest and 0 is all black.
Adressing	Select to address. The write parameters are automatically read from the SD card file and cannot be set on the cloud platform. <b>The coding result is judged by the display color of the lumaires.</b>
Intelligent addressing	After setting the chip and address, click [Set] to send instructions to the main control device under the group.
Debugging control	After setting the channel, check method (point by point / stacking), speed, brightness, click [Start]. The command is sent to the main control device in the group.
GPS	Enable or disable the GPS synchronization function.
Online detection	Check the on-load sub-controller status of the SN controller.

## 9. IP SETTING IN PC

1. Open “Network Connection” on the PC, right click “Local Connection” and select “Properties”.

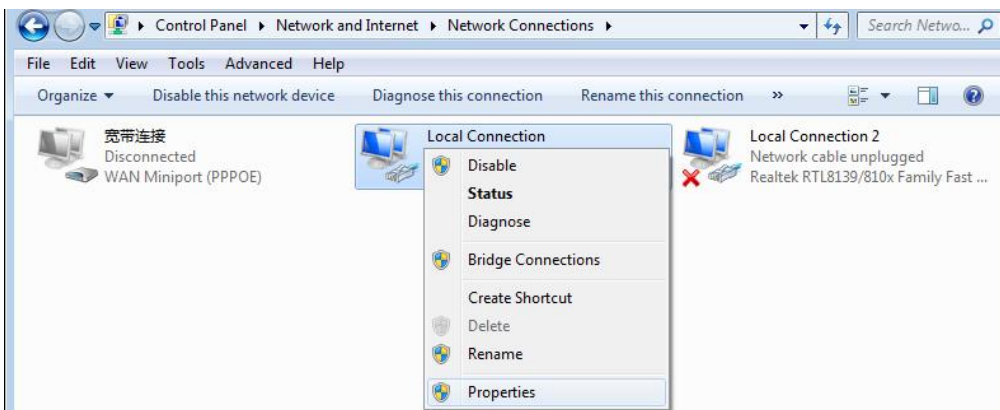

2. Select Internet Protocol (TCP/IP), then click “Properties”. Set the IP address as below.

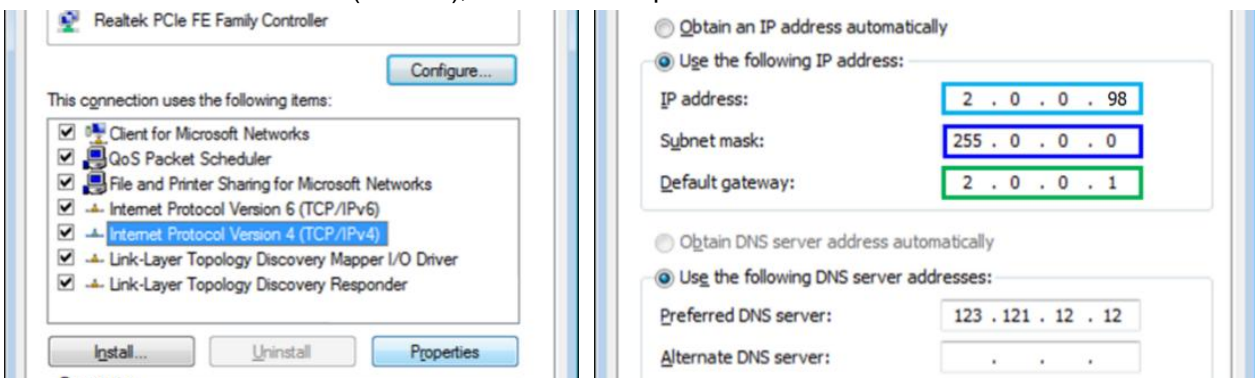

3. Click “OK” after the setting is finished.

## 10. OUTPUT SD FILE AND COPY

### 10.1. OUTPUT SD FILE

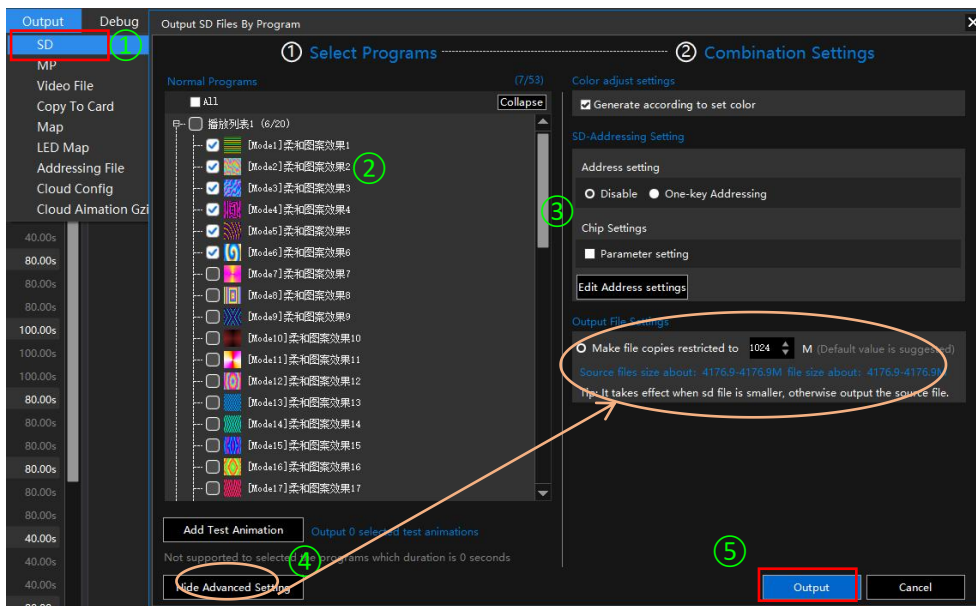

- ① Click “SD” of “Output” in LED Player.
- ② Select the program need to output. The total number of selected programs must be less than 96.
- ③ Select SD-Addressing Setting (Addressing and chip Setting) as required. If this option is not selected, the one-click setting function of the controller is limited. (The chip of SPI protocol skip this step.)
- ④ Select Output File Settings as required.  
Note: LED Player will make recommendations based on the selected effect file size with an upper limit of 1 GB, and can also be customized.
- ⑤ Click “Output”.

Note:

- ✓ The expanded file size does not exceed 80% of the total capacity of the SD card. For a 32GB card, ensure that the file size is within 29GB.
- ✓ The calculation formula is:  $\text{File copies} = \text{total SD card capacity (G)} \times 1024 \times 80\% \div \text{source file size (M)} - 1$  For example: 4G SD card storage, source file size is 100M, it needs to set 31 copies.

### 10.2. COPY BY LED PLAYER

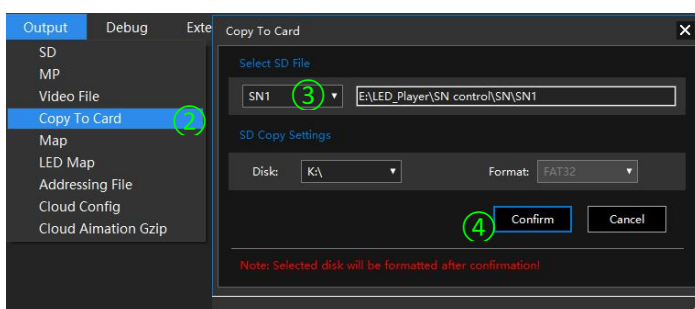

- ①. Input SD card.
- ②. Click “Copy To Card” and open window.
- ③. Select the controller number. (Automatic reading of the corresponding file.)
- ④. Click “Confirm”.

### 10.3. SD CARD COPY

1) Right click the disk where the SD card locates.

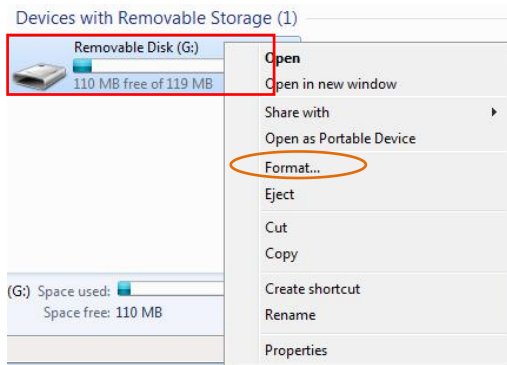

2) Select –exFAT (Can check“Quick Format”) and click START.

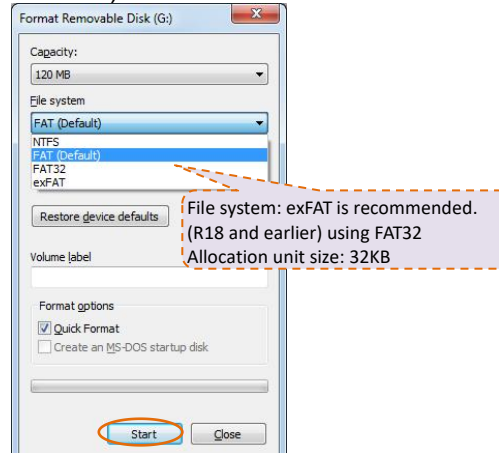

3) Right click N5\_1.Bin file, send the file to Removable Disk.

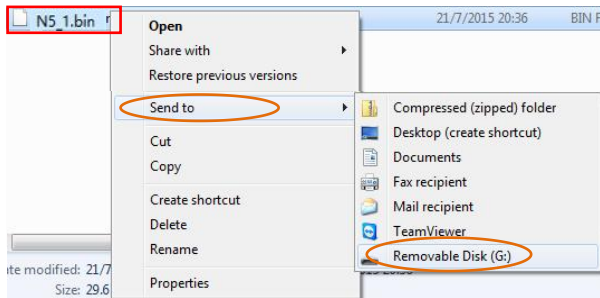

4) Right click removable disk and select “Eject”.

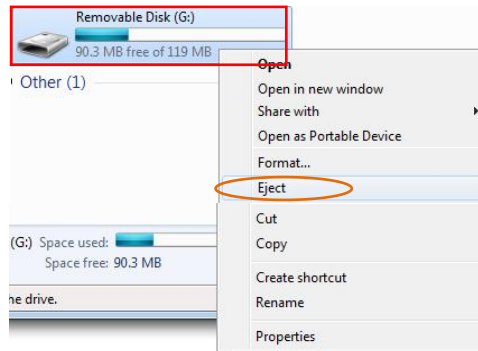

### 11. BACK UP OR REPAIR EFFECTS FILE

In order to avoid SD card damage, file damage, and no SD card, you can switch the effect of playing the storage disk. We need to back up the files in the SD card to the controller in advance. Specific operations are as follows:

1. Each time the controller is powered on, it automatically reads the effect file in the SD card. The operation requirement of bidirectional backup is presented.
2. If necessary, we need to click [Enter] for backup and repair.
3. If not, we can click [Cancel]. Or wait for 3 seconds, the controller will automatically cancel the backup, and enter the basic operation interface.

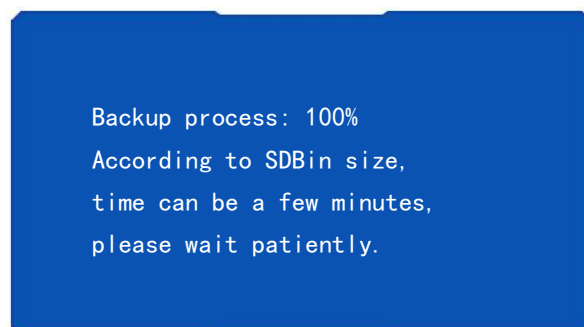
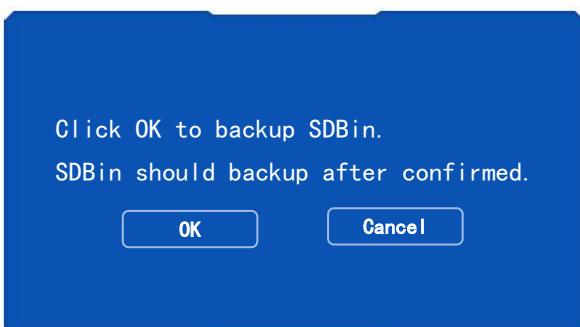

Note: When the controller is backed up/repared, the following message appears:

Display	Reason	Measure
No need to copy / fix	The same effect file has been saved internally and there is no need to back it up again.	We can ignore it.
Cannot copy / fix	<ol style="list-style-type: none"> <li>1. SD card is without effect file.</li> <li>2. The SD card is abnormal.</li> <li>3. The storage disk of the controller is improperly connected or damaged.</li> </ol>	<ol style="list-style-type: none"> <li>1. Please copy the SD card again refer to OUTPUT SD FILE AND COPY.</li> <li>2. Copy SD card again or replace the SD card.</li> <li>3. The storage disk was damaged and returned to factory for repair.</li> </ol>
Copy/Fix bin fail	<ol style="list-style-type: none"> <li>1. Insufficient storage space.</li> <li>2. The backup process is interfered by other signals.</li> <li>3. After three failed backup attempts, the storage disk of the controller is damaged.</li> </ol>	<ol style="list-style-type: none"> <li>1. Reduce the SD card file size</li> <li>2. Re-power on the controller and perform backup operations again.</li> <li>3. The storage disk was damaged and returned to factory for repair.</li> </ol>

## 12. UPDATE SD FILE OR FIRMWARE PROGRAMS LOCALLY

The controller can read the firmware file of the SD card xxxxxx.bin to upgrade the hardware program.

### 12.1. UPDATE ANIMATION ONLINE

The controller can be updated by SNFT\_Tool tool.exe. The update steps are as follows.

1. The computer connects to the SN controller normally (the network card needs to set the static IP address), and double-click to open SNFT\_Tool.exe.
2. Enter the IP address of the SN controller and click [Connect]. At the same time, "Successfully connect Controller" is indicated in the lower left corner.
3. Check [Select file] and select the file named xxxx.bin.
4. Click [Upload] and a progress bar will appear. After uploading, a countdown window will appear in SNFT\_Tool tool. The update is done when the controller restarts automatically.

**Note:** Please make sure to upload the correct bin file, otherwise the controller will report E03 fault after boot.

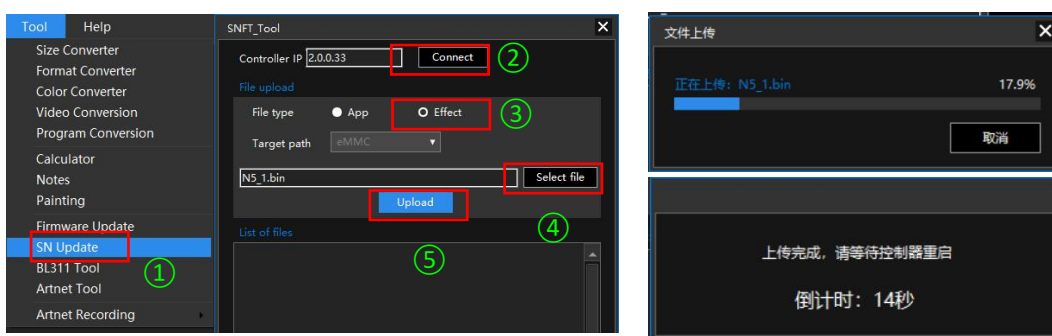

### 12.2. UPDATE FIRMWARE PROGRAMS

#### 12.2.1. GETTING FIRMWARE INFORMATION

Before updating, need to provide the sequence code of the controller to our company. The operation is as follows.

1. Format the SD card according to the steps refer to SD CARD COPY.

2. After creating a.txt file on the SD card, change the text name to SeekwayID.bin.

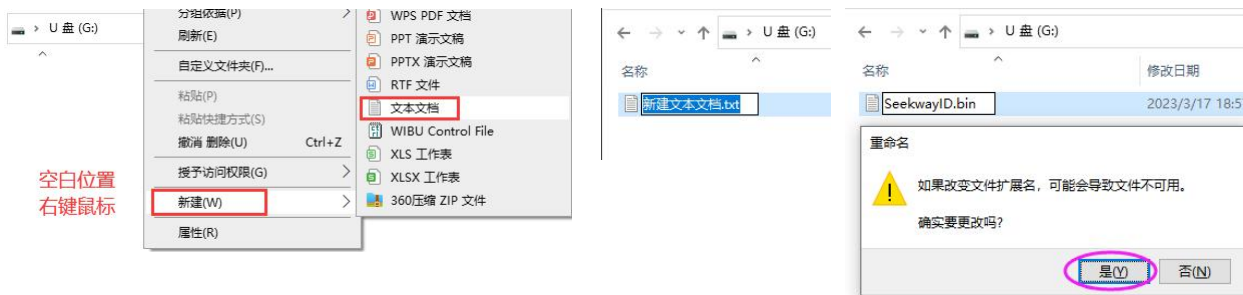

3. When the controller is off, insert the SD card and power it on.
4. If the controller displays "Exx", the serial code reading is successful.
5. At this time, please be sure to power off the controller and take out the SD card.
6. Send the SeekwayID.bin file in the SD card back to us.

Note:

If the controller needs to be upgraded in batches, use the same SD card containing "SeekwayID. bin" to perform steps 3-5 on each controller, and finally send back the SeekwayID. bin file in the card to our company.

### 12.3. UPDATE FIRMWARE VIA SD CARD

1. We generate the firmware file named xxxxxx.bin (xxxxxx is the unique serial number) according to SeekwayID.bin.
2. Copy the xxxxxx.bin file into the SD card referring to 12.3. SD CARD COPY.
3. Plug SD card into the controller and power on. The controller starts to upgrade, and its interface prompts "主板固件升级中" → "主板固件升级完成" → "上盖固件升级中: xx%" → "上盖固件升级完成" in turn. The update is done when the controller restarts automatically.

Note:





If the controller needs to be upgraded in bulk, copy all the firmware files generated by our company to the same SD card and upgrade the controller by inserting the card.



### 13. ERROR CODE AND TROUBLE SHOOTING

Error	Reason	Measure
E 01	No SD card. SD card or storage disk is broken.	<ol style="list-style-type: none"> <li>1. Insert the SD card and backup the file into storage disk again.</li> <li>2. If an error occurs when inserting the SD card, some components are in abnormal contact. Return to depot.</li> </ol>
E 02	SD card no response or breakdown.	<ol style="list-style-type: none"> <li>1. Please re-copy the SD card according to "OUTPUT SD FILE AND COPY", and re-back up the file to the storage disk.</li> <li>2. Please replace the new SD card.</li> <li>3. If an error occurs when inserting the SD card, some components are in abnormal contact. Return to depot.</li> </ol>
E 03	There is no file in the SD card.	Please re-copy the SD card according to "OUTPUT SD FILE AND COPY", and re-back up the file to the storage disk.
E 05	Cannot read part of the card or bad connection.	<ol style="list-style-type: none"> <li>1. This error is negligible when the luminaire normally plays the animation.</li> <li>2. If the luminaire can not play the animation normally, please re-copy the SD card according to "OUTPUT SD FILE AND COPY", and re-back up the file to the storage disk.</li> </ol>
E 07	SD card file sequence doesn't match the controller.	SD card file error. or unfinished video merging. Please open the corresponding code to output the SD card file and copy again.
E 09	The sequence of the controller is not consistent with the sequence of the program file.	Please use the correct project.
E 18	The number of loaded pixels exceeds the upper limit.	Please reduce the number of project pixels.
E 19	Invalid file, please check whether the project and master control match.	Please check whether the project and master control match.
E 27	The SD card has too many bad areas.	Please re-copy the SD card according to "OUTPUT SD FILE AND COPY", and re-back up the file to the storage disk.
E 29	SD card format unit is incorrect, please use "32K" to reformat and copy the card.	Please use "32K" to reformat and copy the card.

## 14. FITTINGS

Shows	Item	Number	Remark
	SD Card	1	
	Power line	1	
	Cat5E (T568B to T568B)	1	Selected
	GPS Antenna	1	Selected
	4G Antenna (3 meters)	1	Selected