



# SY-302G(CG) MANUAL

Version: 4.0

Model: SY-302G-K1  
SY-302CG-K1

2024-6

# Contents

|   |           |
|---|-----------|
| <b>1. FUNCTION OVERVIEW</b> .....                           | <b>1</b>  |
| <b>2. TECHNICAL PARAMETERS</b> .....                        | <b>1</b>  |
| 2.1. PRODUCT INFORMATION .....                              | 1         |
| 2.2. COMPONENT .....  | 2         |
| <b>3. CONNECTION MODE</b> .....                             | <b>2</b>  |
| 3.1. APPLICATION SOLUTION .....                             | 2         |
| 3.1.1. ISENGAGES FROM CLOUD CONTROL .....                   | 2         |
| 3.1.2. SINGLE GPS SYNCHRONIZATION .....                     | 3         |
| 3.2. CONNECTION MODE .....                                  | 3         |
| 3.3. GPS ANTENNA AND 4G ANTENNA REQUIRE .....               | 4         |
| <b>4. BASIC OPERATION</b> .....                             | <b>5</b>  |
| 4.1. BOOT DISPLAY .....                                     | 5         |
| 4.2. BUTTONS OPERATION .....                                | 5         |
| 4.2.1. BUTTONS FUNCTION .....                               | 5         |
| 4.2.2. SATELLITE SIGNAL .....                               | 5         |
| 4.2.3. SPEED SELECTION .....                                | 6         |
| 4.2.4. EFFECT SWITCHING .....                               | 6         |
| 4.2.5. RESTORE FACTORY SETTINGS .....                       | 6         |
| <b>5. WRITING ADDRESSING AND PARAMETERS QUICKLY</b> .....   | <b>6</b>  |
| 5.1. CHIP SUPPORTED .....                                   | 6         |
| 5.2. SUCCESSFULLY ADDRESSED AND SETTING PARAMETERS .....    | 7         |
| 5.3. SUPPORT FOR VERSION OF LED PLAYER .....                | 8         |
| 5.4. ADDRESSING AND WRITE PARAMETER .....                   | 9         |
| 5.4.1. SETTING THE ADDRESSING IN LED PLAYER .....           | 9         |
| 5.4.2. SETTING THE PARAMETERS IN LED PLAYER .....           | 9         |
| 5.4.3. SETTING THE CHIP PROPERTY IN LED PLAYER .....        | 10        |
| 5.4.4. OPERATION ON THE CONTROLLER .....                    | 10        |
| <b>6. FIRMWARE UPDATE</b> .....                             | <b>11</b> |
| <b>7. REMOTE OPERATION OF CLOUD CONTROL SYSTEM</b> .....    | <b>11</b> |
| 7.1. GETTING THE DEVICE CODE .....                          | 11        |
| 7.2. SETTING BY CLOUD SERVER OF WEBSITE .....               | 12        |
| 7.2.1. ACCESS STEPS ON WEBSITE .....                        | 12        |
| 7.2.2. SETTING THE STATE BY CLOUD SERVER ON WEBSITE .....   | 13        |
| 7.2.3. ADDRESSING BY CLOUD SERVER ON WEBSITE .....          | 13        |
| 7.3. SETTING BY CLOUD SERVER OF PHONE .....                 | 13        |
| 7.3.1. ACCESS STEPS ON THE PHONE .....                      | 13        |
| 7.3.2. SETING AND ADDRESSING BY CLOUD SERVER ON PHONE ..... | 14        |
| <b>8. OUTPUT AND COPY THE SD CARD FILE</b> .....            | <b>15</b> |
| 8.1. OUTPUT THE SD CARD FILE .....                          | 15        |
| 8.2. COPY THE SD FILE BY LED PLAYER .....                   | 15        |
| 8.3. MANUAL FORMAT AND COPY CARD .....                      | 16        |
| <b>9. ERROR CODE</b> .....                                  | <b>16</b> |
| <b>10. FITTINGS</b> .....                                   | <b>17</b> |

# 1. FUNCTION OVERVIEW

1. GPS Satellite synchronization. Short positioning time and accurate positioning.
2. No need to connect cables between controllers. After set the mode and speed of all the controllers to be the same, it will go to synchronous system in 2 minutes.(No need to restart the controllers)  
GPS Satellite synchronous controller is applicable to the situation that the lighting cannot be connected among buildings. Besides, the synchronous display and the overall effect display are available.
3. 2-port output signal (data-independent).  
SW Single chip: D\*\*S, D\*\*J.  
SPI: TM180\*-400K/800K, UCS19\*\*, UCS29\*\*, WS2811/12, TLS3001(1Mhz), SM167\*\*, TM1913-790K, TM-1913-790K.  
DMX512: SW-D, SW-U, UCS512A/B/C0/C4/D/E0/EH, DMX512AP/SM512, SM16500P/511/512, SM17500P/512P/522P, SM17512/522, SM18522/522PH, Hi512A0/A4/A6/D/E, TM512AB3/AL1/ACx/AD, QED512P, GS8512/513/515, standard DMX512 luminaire on the market.  
Please refer to the "CHIP SUPPORT" section for addressing.  
Breakpoint resume: UCS5603, WS2818, GS8206, P9883, TM1914, XT1506S.
4. Set the address and parameters of chip, it will write them while the controller power on.

## 2. TECHNICAL PARAMETERS

### 2.1. PRODUCT INFORMATION

- Cover material: Iron
- Input voltage: AC 100V - 240V
- Output port: RS-485 & TTL×2 channels
- Pixel drove: SPI: 3072 channels ×2 ports,  
Standard DMX512: 512 channels ×2 ports, Extensible DMX: 1024 channels ×2 ports,  
Breakpoint resume: 2160 channels ×2 ports.
- Output power: <3W
- Working temperature: -15℃~60℃
- Relative humidity: ≤50%
- IP grade: IP20 (Prevent people from touching the components inside electrical appliance, prevent object which diameter is more than 12.5mm from getting in, no special protection to water or moisture.)
- Working environment:
1. Please do not install the controller in magnetic, high pressure, high temperature or seriously wet environment.
  2. Please do connect the earth safely in order to reduce risks of fire and damage which cause by short circuit.
  3. Please ensure AC100-240V power supply is used, and same polarity is connected between transformer and controller in order to guarantee the proper supply voltage.
  4. No waterproof function in the control system, please pay attention on rainproof and waterproof during installing.

Net weight: 0.55 Kg  
 Size: L193\*W122\*H43  
 (Unit: mm)

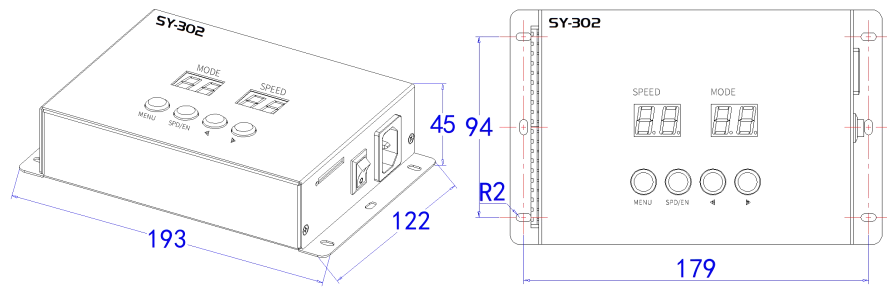

## 2.2. COMPONENT

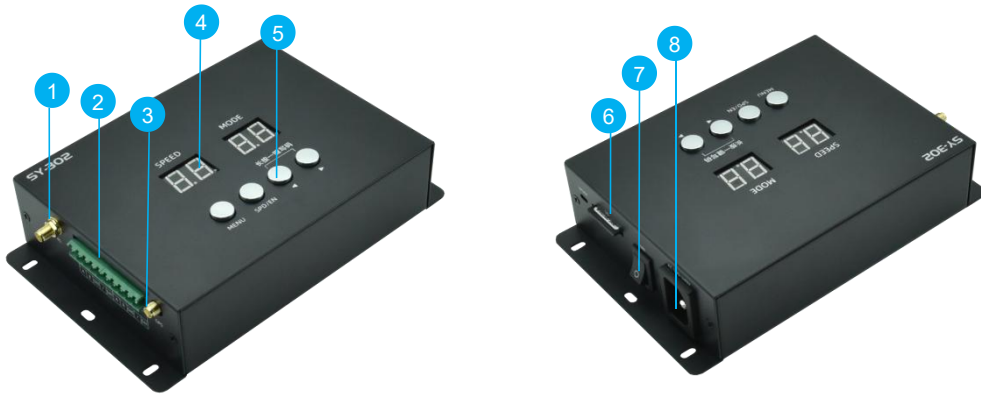

- ① 4G antenna socket (only for 4G)
- ② Output control luminaire
- ③ GPS antenna socket
- ④ Nixie tube
- ⑤ Control button
- ⑥ SD card port
- ⑦ Power switch
- ⑧ Power input AC100-240V

## 3. CONNECTION MODE

### 3.1. APPLICATION SOLUTION

#### 3.1.1. ISENGAGES FROM CLOUD CONTROL

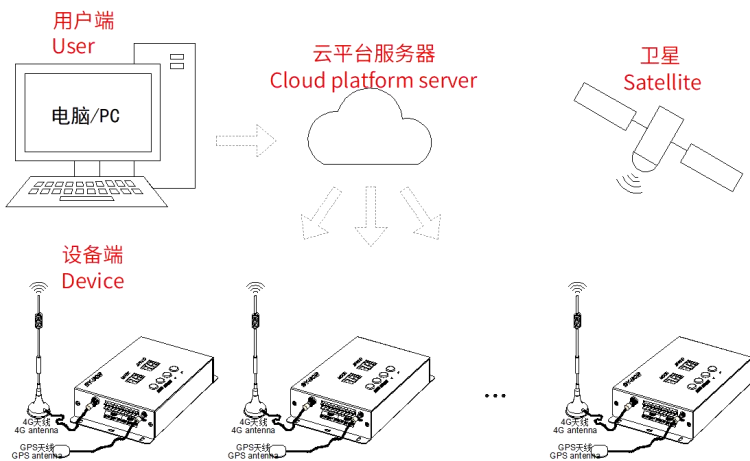

### 3.1.2. SINGLE GPS SYNCHRONIZATION

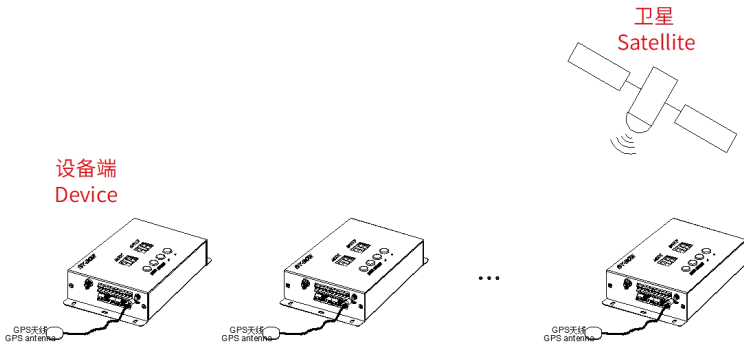

### 3.2. CONNECTION MODE

Please connect the cables in accordance with silk print on luminaires.

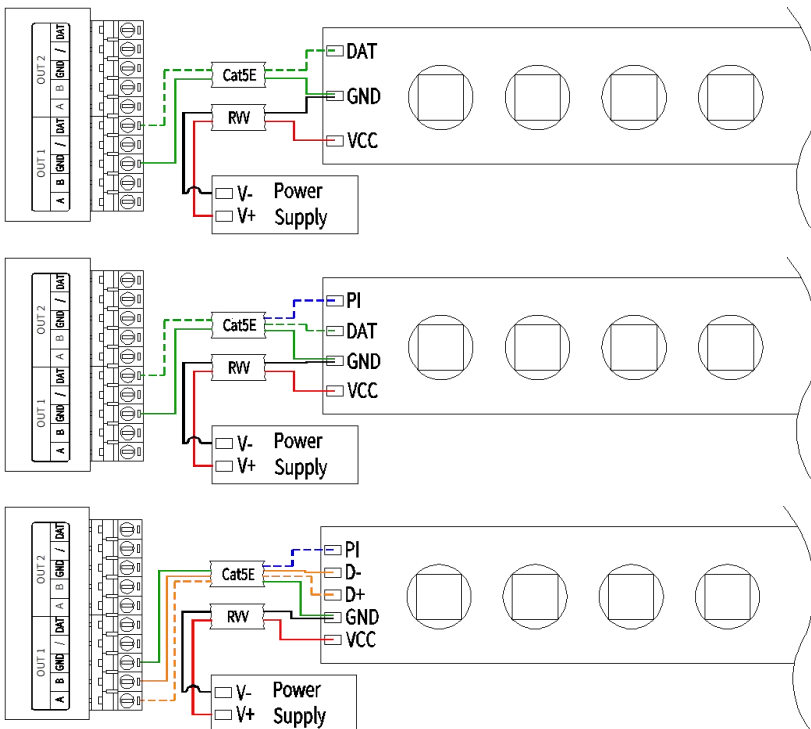

★ Signal cables connection cautions:

1. Use UTP—Unshielded Twisted Pair (resistance per 100M<10Ω), low quality Ethernet cables, telephone cables and copper wires are unavailable.
2. Use one group twisted pair, suggest green + green white or orange + orange white. The quality and color of the cable are very important. Blue and brown wires greatly influence the signal transmission. Please don't use several groups of twisted pairs together.
3. Controller signal output GND must connect directly with input GND of luminaire. Cannot connect with luminaire through power supply.
4. Switch on the controller after all hardware signal and power cables are connected. Please don't CONNECT / DISCONNECT the signal cables while the controller is power on; avoid back-flow current burning circuit and components of output port.

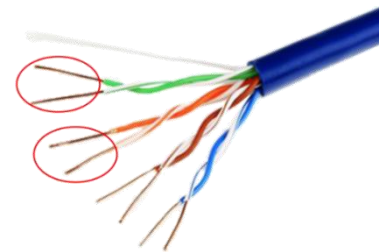

## TRANSMISSION DISTANCE

| Transmission Type   | Signals          | Medium          | Distance (M) | Remark  |
|---|------------------|-----------------|--------------|---|
| MP / PC → EN controller<br>EN controller → EN controller        | 100M<br>Ethernet | UTP CAT5e       | 50-80        |   |
| EN controller→DMX lighting<br>DMX lighting→DMX lighting         | RS-485           | UTP CAT5e       | 30-50        | The address wire must be within 5m.<br>Controllable pixels reduce if wire is over 5m. |
|   |                  | Three core wire | 1-20         |   |
|   |                  | Four core wire  | 1-20         |   |
| EN controller→Single-wire lighting<br>DMX lighting→DMX lighting | TTL              | UTP CAT5e       | 5-20         | Pixels controlled less if over 1m.  |
|   |                  | Two core wire   | 1-5          |   |
|   |                  | Three core wire | 1-5          |   |
| Single-wire lighting→Single-wire lighting                       | TTL              | UTP CAT5e       | 1-2          | Pixels controlled less if over 1m.  |
|   |                  | Two core wire   | 0.1-1        |   |

## 3.3. GPS ANTENNA AND 4G ANTENNA REQUIRE

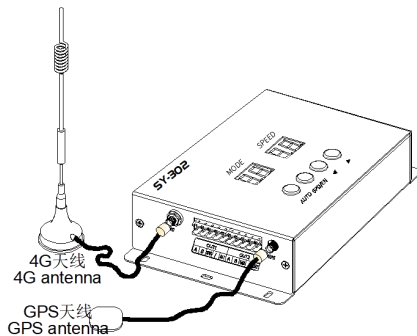

### 1. GPS antenna,

3m GPS antenna is provided. User can also purchase GPS marine antenna with standard SMA interface according to on-site engineering requirement. The longer the antenna is, the more difficult to search satellite.

- 1) GPS Antenna should be installed in open space to guarantee view angle within 30 degree, there is no big shades (such as trees, iron towers, buildings etc.). GPS Antenna should be more than 2m away from the metal objects which size is bigger than 20cm.
- 2) Due to the satellite appearing on the equator more than other places, it preferably put the GPS antenna in the south of location for the north hemisphere.
- 3) Please don't put GPS antenna around other transmitting and receiving equipment to avoid radiation of other transmitting antenna facing to GPS antenna. Please keep them 2m away with each other.

### 2. 4G antenna,

The controller is equipped with 4G module and 4G iot card. Access to the antenna as shown in the figure, and access to 4G network can be realized by electrification.

- a) Try to place the antenna as high as possible, and close to the open air.
- b) Applicable to China only.

## 4. BASIC OPERATION

### 4.1. BOOT DISPLAY

“b 03” → “K 1” → “88 88” is displayed when the controller power on.

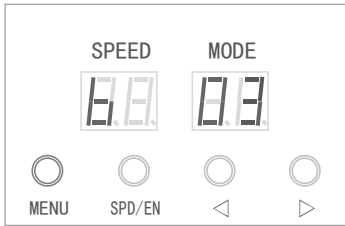

The boot program version.

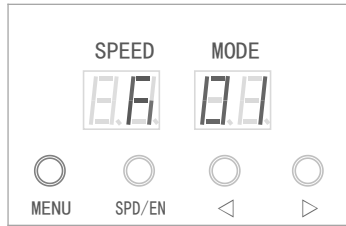

The controller's version.

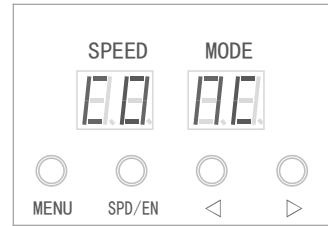

Cat1 is initializing.

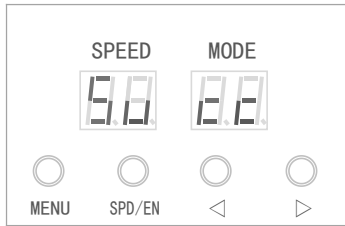

Successfully connect to cloud service.

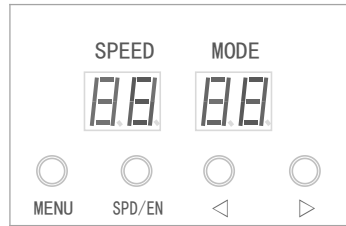

Initializing

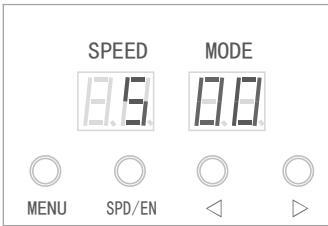

Normal working interface

### 4.2. BUTTONS OPERATION

#### 4.2.1. BUTTONS FUNCTION

| Button | Operation   | Function  |
|--------|-------------|---|
| MENU   | Short press | Signal strength of searched GPS satellite, real time (mm:ss) searched by GPS. |
|        | Long press  | Set the full loop.  |
| SPD/EN | Short press | Set the speed.  |
| ◀      | Short press | Decrease the mode.  |
|        | Long press  | Decrease quickly the mode.  |
| ▶      | Short press | Increase the mode.  |
|        | Long press  | Increase quickly the mode.  |

#### 4.2.2. SATELLITE SIGNAL

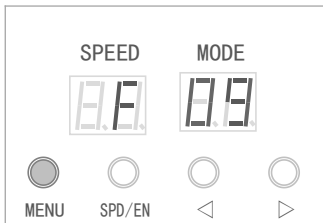

Press “MENU” once, it shows “F \*\*”. (\*\* is the signal strength of searched GPS satellite. Larger value with better signal.) **It will be synchronization if “F 09”.**

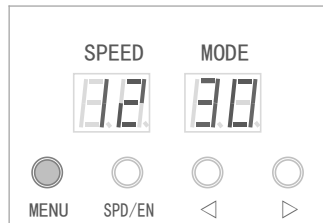

Press “MENU” once, it shows the real Beijing time (mm ss) searched by GPS.

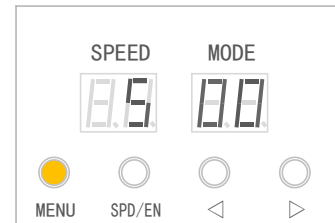

Long press “MENU”, the mode shows “00” (audio mode).

**★ Press "SPD/EN", "◀" or "▶" to return to "Normal Mode" interface from "Satellite" interface. The controller will save the previous speed and effect mode.**

### 4.2.3. SPEED SELECTION

Press button “SPD/EN” on control panel to select play speed, the less the rate, the quicker the speed.

| Parameters     |    |    |    |    |    |    |    |    |    |    |    |    |     |     |     |     |
|----------------|----|----|----|----|----|----|----|----|----|----|----|----|-----|-----|-----|-----|
| Interface      | 2  | 2. | 3  | 3. | 4  | 4. | 5  | 5. | 6  | 7  | 8  | 9  | 10  | 11  | 12  | 15  |
| Frame Rate(ms) | 20 | 25 | 30 | 35 | 40 | 45 | 50 | 55 | 60 | 70 | 80 | 90 | 100 | 110 | 120 | 150 |
| (fps)          | 50 | 40 | 33 | 28 | 25 | 22 | 20 | 18 | 17 | 14 | 13 | 11 | 10  | 9   | 8   | 7   |

### 4.2.4. EFFECT SWITCHING

Press “◀” and “▶” on control panel to select effects.



Press “MENU” once, Mode = 0. Press “▶” 9 times, Mode = 09.

### 4.2.5. RESTORE FACTORY SETTINGS

Press and hold “SPD/EN” and “◀”, power onto enter the reset state, after the successful reset will automatically restart.

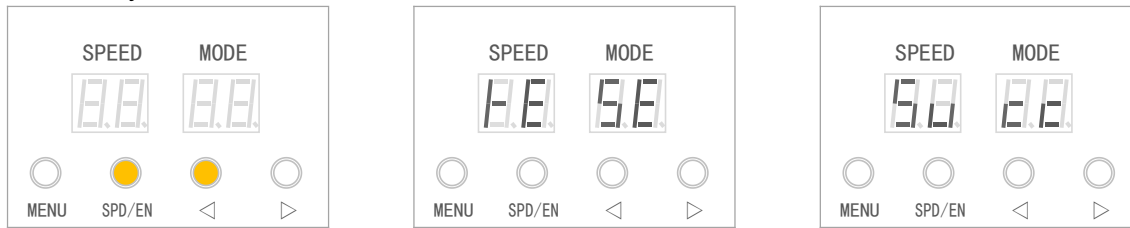

Press and hold “SPD/EN” and “◀”, power it on.

Resetting

Reset successfully.

## 5. WRITING ADDRESSING AND PARAMETERS QUICKLY

### 5.1. CHIP SUPPORTED

| Chip     | Addressing | Custom Channel | Set parameters  |                  |         |         |       |       |
|----------|------------|----------------|-----------------|------------------|---------|---------|-------|-------|
|          |            |                | No signal State | Power-on Setting | Current | Forward | Issue | GAMMA |
| UCS512A  | √          | ×              | ×               | ×                | ×       | ×       | ×     | ×     |
| UCS512B  | √          | ×              | ×               | ×                | ×       | ×       | ×     | ×     |
| UCS512C0 | √          | ×              | ×               | ×                | ×       | ×       | ×     | ×     |
| UCS512C4 | √          | ×              | ×               | √                | ×       | ×       | ×     | ×     |
| UCS512CN | √          | ×              | √               | √                | ×       | ×       | ×     | ×     |
| UCS512D  | √          | ×              | √               | √                | √       | ×       | ×     | ×     |
| UCS512E0 | √          | √              | √               | √                | √       | √       | ×     | ×     |
| DMX512AP | √          | ×              | ×               | ×                | ×       | ×       | ×     | ×     |
| SM16511  | √          | ×              | ×               | ×                | ×       | ×       | ×     | ×     |
| SM16512  | √          | ×              | ×               | ×                | ×       | ×       | ×     | ×     |
| SM16520  | √          | ×              | ×               | ×                | ×       | ×       | ×     | ×     |
| SM16500  | √          | ×              | √               | √                | ×       | ×       | ×     | ×     |

| Chip      | Addressing | Custom Channel | Set parameters  |                  |         |         |       |       |
|-----------|------------|----------------|-----------------|------------------|---------|---------|-------|-------|
|           |            |                | No signal State | Power-on Setting | Current | Forward | Issue | GAMMA |
| SM17500   | √          | √              | √               | √                | √       | x       | x     | x     |
| SM17512   | √          | x              | √               | √                | √       | x       | x     | x     |
| SM17522   | √          | x              | √               | √                | √       | x       | x     | x     |
| SM18522P  | √          | x              | √               | √                | √       | x       | x     | √     |
| SM18522PH | √          | x              | √               | √                | √       | x       | x     | √     |
| SM18512P  | √          | x              | x               | x                | x       | x       | x     | x     |
| SM18512PK | √          | x              | x               | x                | x       | x       | x     | x     |
| SM16522P  | √          | x              | x               | x                | x       | x       | x     | x     |
| SM16522PS | √          | x              | x               | x                | x       | x       | x     | x     |
| SM19522PS | √          | x              | x               | x                | x       | x       | x     | x     |
| SW-D      | √          | x              | x               | x                | x       | x       | x     | x     |
| Hi512A0   | √          | √              | x               | x                | x       | x       | x     | x     |
| Hi512A4   | √          | x              | √               | √                | x       | x       | x     | x     |
| Hi512A6   | √          | x              | √               | √                | x       | x       | x     | x     |
| Hi512D    | √          | x              | √               | √                | √       | x       | x     | x     |
| Hi512E    | √          | x              | √               | √                | √       | x       | x     | x     |
| Hi512B4L  | √          | x              | x               | x                | x       | x       | x     | x     |
| TM512AB3  | √          | x              | x               | x                | x       | x       | x     | x     |
| TM512AL1  | √          | x              | x               | x                | x       | x       | x     | x     |
| TM512ACx  | √          | x              | x               | x                | x       | x       | x     | x     |
| TM512AD   | √          | x              | √               | √                | √       | x       | x     | x     |
| QED512P   | √          | x              | √               | √                | √       | x       | x     | x     |
| GS8511    | √          | x              | x               | x                | x       | x       | x     | x     |
| GS8512    | √          | x              | x               | x                | x       | x       | √     | √     |
| GS8513    | √          | x              | x               | x                | √       | x       | √     | √     |
| GS8515    | √          | x              | x               | x                | √       | x       | √     | √     |

## 5.2. SUCCESSFULLY ADDRESSED AND SETTING PARAMETERS

| Chip     | Lighting color after power on | Addressed  |            | Byte + No signal + No signal |            | Current parameter |            | Self-Channel Setting |            |
|----------|-------------------------------|------------|------------|------------------------------|------------|-------------------|------------|----------------------|------------|
|          |                               | First chip | Other chip | First chip                   | Other chip | First chip        | Other chip | First chip           | Other chip |
| UCS512A  | White                         | Blue       | Blue       | -                            | -          | -                 | -          | -                    | -          |
| UCS512A1 | White                         | Blue       | Blue       | -                            | -          | -                 | -          | -                    | -          |
| UCS512A2 | White                         | Blue       | Blue       | -                            | -          | -                 | -          | -                    | -          |
| UCS512B3 | White                         | Blue       | Blue       | -                            | -          | -                 | -          | -                    | -          |
| UCS512C  | Custom                        | White      | White      | -                            | -          | -                 | -          | -                    | -          |
| UCS512C0 | -                             | White      | White      | -                            | -          | -                 | -          | -                    | -          |
| UCS512C3 | Custom                        | White      | White      | Red                          | Red        | -                 | -          | -                    | -          |
| UCS512C4 | Custom                        | White      | White      | Red                          | Red        | -                 | -          | -                    | -          |
| UCS512CN | Custom                        | Yellow     | White      | Yellow                       | Power on   | -                 | -          | -                    | -          |
| UCS512D  | Custom                        | Yellow     | White      | Yellow                       | Power on   | Yellow            | Red        | -                    | -          |

| Chip      | Lighting color after power on | Addressed  |            | Byte + No signal + No signal |            | Current parameter |            | Self-Channel Setting |            |
|-----------|-------------------------------|------------|------------|------------------------------|------------|-------------------|------------|----------------------|------------|
|           |                               | First chip | Other chip | First chip                   | Other chip | First chip        | Other chip | First chip           | Other chip |
| UCS512E0  | Custom                        | Yellow     | White      | Yellow                       | Power on   | -                 | -          | Yellow               | Green      |
| UCS512EH  | Custom                        | Yellow     | White      | Yellow                       | Power on   | Yellow            | Red        | Yellow               | Green      |
| DMX512AP  | -                             | White      | White      | -                            | -          | -                 | -          | -                    | -          |
| SM16512   | -                             | Green      | Green      | -                            | -          | -                 | -          | -                    | -          |
| SM16511   | -                             | Green      | Green      | -                            | -          | -                 | -          | -                    | -          |
| SM16520   | -                             | Green      | Green      | -                            | -          | -                 | -          | -                    | -          |
| SM16500   | Custom                        | Red        | Green      | Red                          | Power on   | -                 | -          | -                    | -          |
| SM17500   | Custom                        | Red        | Green      | Red                          | Power on   | Red               | Yellow     | Red                  | Purple     |
| SM17512   | Custom                        | Red        | Green      | Blue                         | Blue       | -                 | -          | -                    | -          |
| SM17522   | -                             | Red        | Green      | Red                          | Blue       | Red               | Yellow     | -                    | -          |
| SM18522P  | Custom                        | Red        | Green      | Blue                         | Blue       | -                 | -          | -                    | -          |
| SM18522PH | -                             | Red        | Green      | Red                          | Blue       | Red               | Yellow     | -                    | -          |
| SW-D      | -                             | Yellow     | Green      | -                            | -          | -                 | -          | -                    | -          |
| Hi512A4   | Custom                        | Red        | Green      | Red_                         | Green      | -                 | -          | -                    | -          |
| Hi512A6   | Custom                        | Red        | Green      | Red                          | Green      | -                 | -          | -                    | -          |
| Hi512A0   | -                             | White      | White      | White                        | White      | -                 | -          | -                    | -          |
| Hi512D    | -                             | Red        | Green      | Green                        | Green      | Green             | Green      | -                    | -          |
| Hi512E    | -                             | Red        | Green      | Green                        | Green      | Green             | Green      | -                    | -          |
| TM512AB3  | White                         | Blue       | Blue       | -                            | -          | -                 | -          | -                    | -          |
| TM512AL1  | White                         | Blue       | Blue       | -                            | -          | -                 | -          | -                    | -          |
| TM512AC0  | -                             | White      | White      | -                            | -          | -                 | -          | -                    | -          |
| TM512AC2  | Custom                        | White      | White      | -                            | -          | -                 | -          | -                    | -          |
| TM512AC3  | Blue                          | White      | White      | -                            | -          | -                 | -          | -                    | -          |
| TM512AC4  | Blue                          | White      | White      | -                            | -          | -                 | -          | -                    | -          |
| TM512AD   | Blue                          | Yellow     | White      | Yellow                       | Power on   | Yellow            | Red        | -                    | -          |
| GS8511    | -                             | Red        | Cyan       | -                            | -          | -                 | -          | -                    | -          |
| GS8512    | Custom                        | Red        | Cyan       | -                            | -          | -                 | -          | -                    | -          |
| GS8513    | Red+Cyan                      | Red        | Cyan       | -                            | -          | -                 | -          | -                    | -          |
| GS8515    | Red+Cyan                      | Red        | Cyan       | -                            | -          | -                 | -          | -                    | -          |

### 5.3. SUPPORT FOR VERSION OF LED PLAYER

LED Player 3.2 or later version.

## 5.4. ADDRESSING AND WRITE PARAMETER

### 5.4.1. SETTING THE ADDRESSING IN LED PLAYER

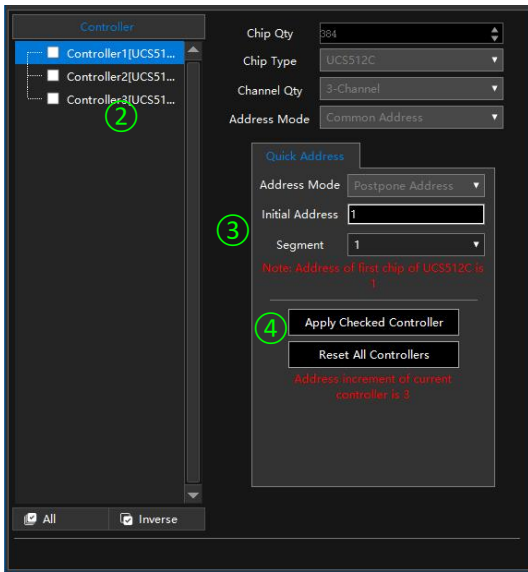

1. Click “Quickly Addressing” of Debug, and open the setting windows.
2. Select the controller be set.
3. Set the initial address and segment.
4. Click “Apply Checked Controller” to save.
5. Close and quit.
6. Output and copy the SD card. (Please refer to OUTPUT AND COPY THE SD CARD FILE.)

### 5.4.2. SETTING THE PARAMETERS IN LED PLAYER

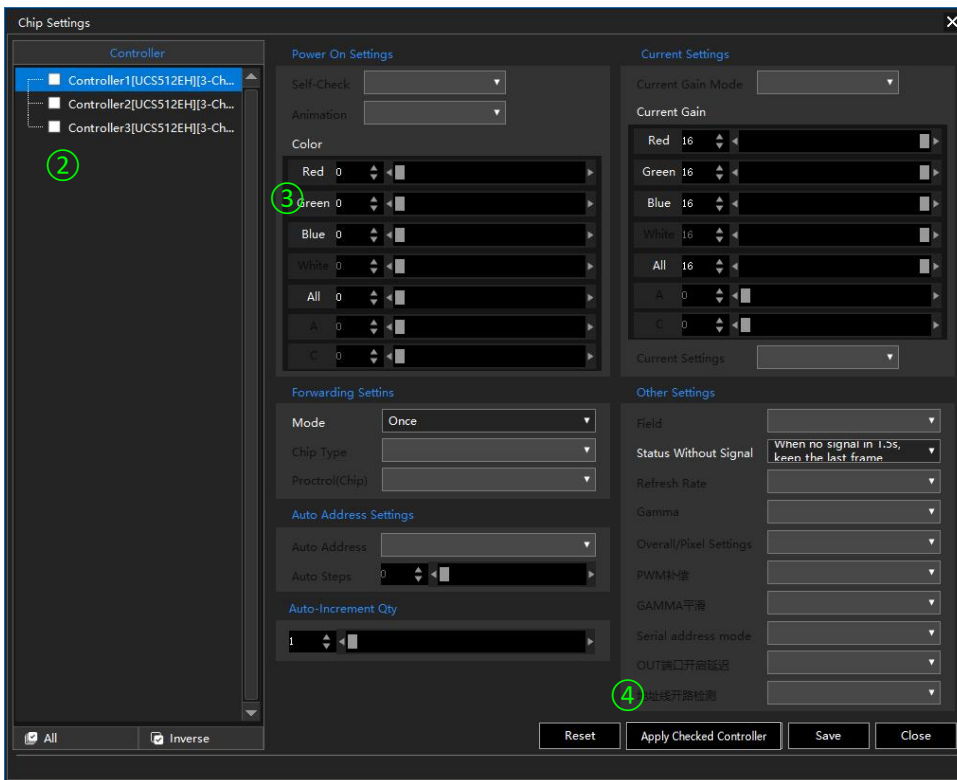

1. Click “Chip” of Settings, and open the setting windows.
2. Select the controller be set.
3. Set the parameters of chip.
4. Click “Apply Checked Controller” to save.
5. Close and quit.
6. Output and copy the SD card. (Please refer to OUTPUT AND COPY THE SD CARD FILE.)

### 5.4.3. SETTING THE CHIP PROPERTY IN LED PLAYER

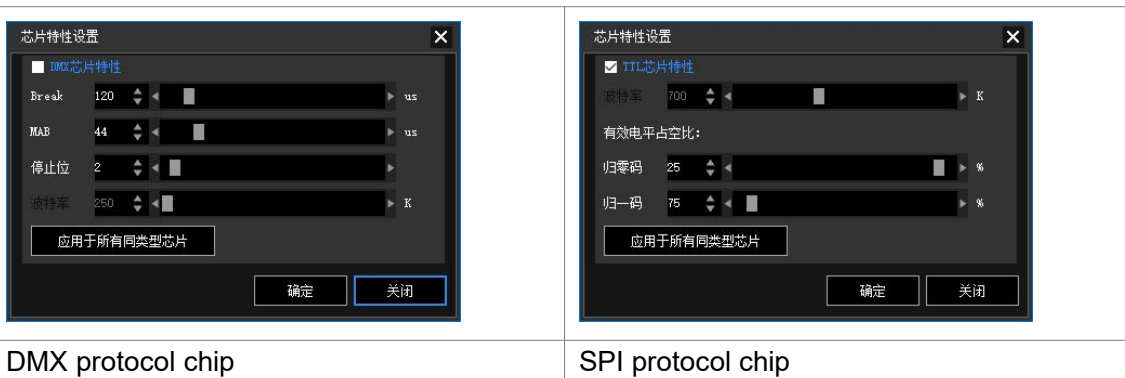
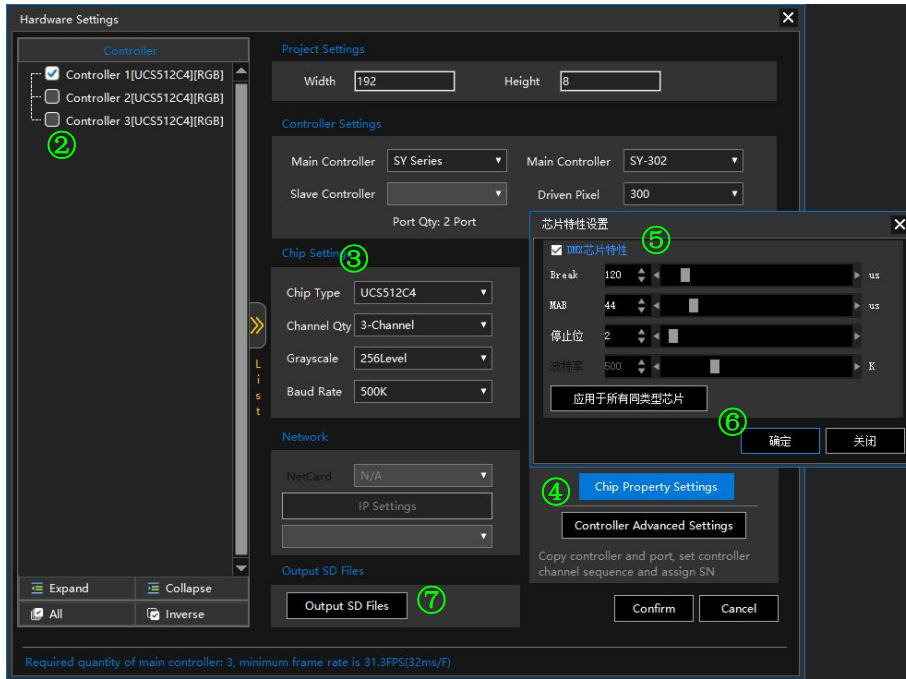

DMX protocol chip

SPI protocol chip

- ① Click “Hardware Settings” of Settings, and open the setting windows.
- ② Select the controller be set.
- ③ Select the chip type.
- ④ Click “Chip Property Settings” to open the setting window.
- ⑤ Check and set the value.
- ⑥ Click “确定” and close the window.
- ⑦ Output and copy the SD card. (Please refer to OUTPUT AND COPY THE SD CARD FILE.)

### 5.4.4. OPERATION ON THE CONTROLLER

Put into the SD card.

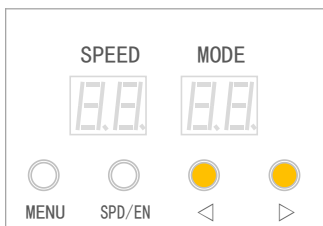

Press and hold ◀ and ▶, power on.

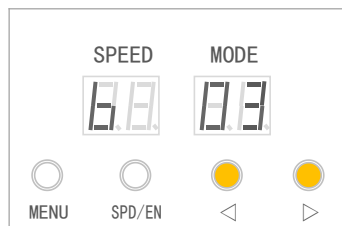

It show “b 03”.  
(Protect long press button.)

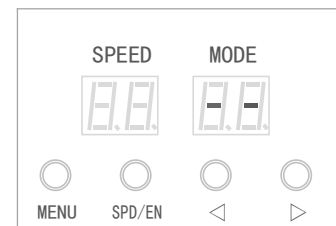

Release the button when it shows “- -”, then it start addressing and setting parameters.

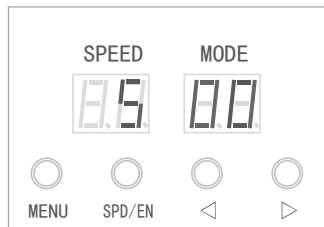
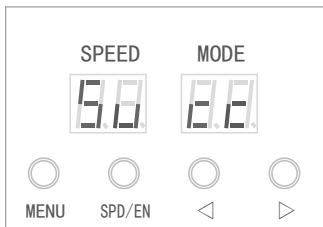

It will restart after show "Su cc". It will restart after setting.

Order of setting parameters: Setting adaptive channel → Setting parameters → Addressing → Adaptive channel coding → Addressing check → Checking Genies chip

Addressing check: First chip lights yellow and the others light green 3 seconds → Goes off 3 seconds → White scan

## 6. FIRMWARE UPDATE

The controller supports reading the SD card parameters (T302\_xxx.bin file) to update its procedure. Please refer to the follow steps.

1. Please refer to MANUAL FORMAT AND COPY CARD and copy the T302\_xxx.bin file into SD card.
2. Power on the controller after inserting the SD card. The nixie display shows "UP --" and it will start to update.
3. The nixie display shows "Succ" when finishing update. Power off the controller and insert the SD card with the SD(8888).bin file into. After the controller is powered on, it can continue to work.

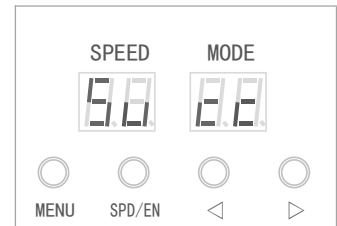
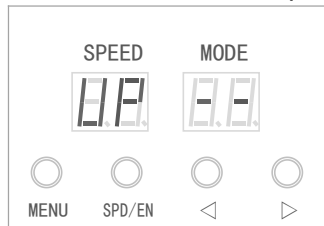
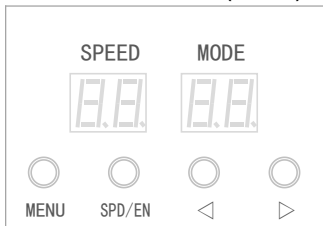

## 7. REMOTE OPERATION OF CLOUD CONTROL SYSTEM

SY-302CG controller has built-in 4G card. The correct access to our cloud platform can realize the functions of remote setup, address writing.

### 7.1. GETTING THE DEVICE CODE

A sticker printed with the UID code of the controller and the corresponding two-dimensional code is affixed to the side of the controller. It can be seen that in the next section, enter the engineering code of this sticker and use the mobile phone to scan the code and bind.



When the sticker is damaged and the display information is incomplete and cannot be bound, we can get the UIDcode in the following ways.

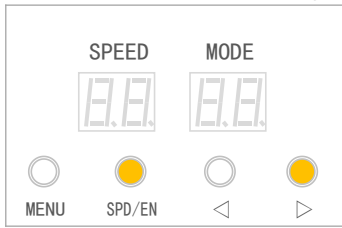

Press and hold down SPD/EN and ►, power on.

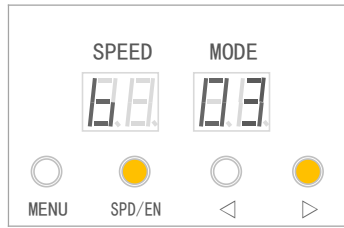

Shows the boot version (hold down SPD/EN and ►).

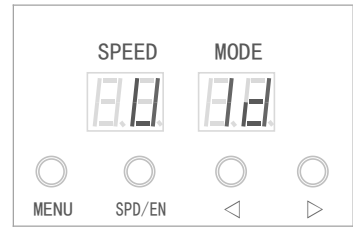

Shows the UID text and release the button.

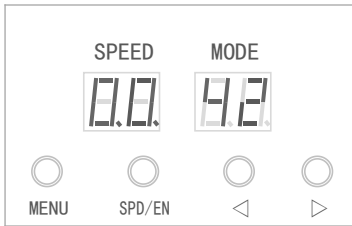

The UID start code is displayed “.” in the lower left corner

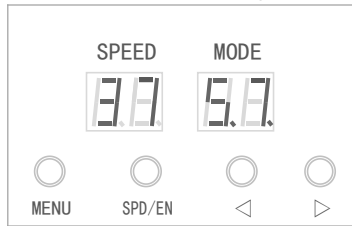

The UID end code is displayed “.” in the lower left corner

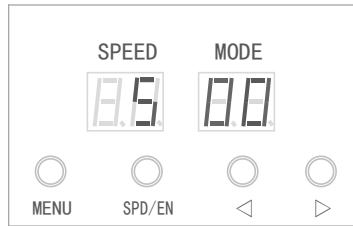

When the display is complete, the main screen is displayed.

● The 24 bit UID code shows in sequence,

|              |             |              |             |              |             |              |             |              |             |              |             |
|--------------|-------------|--------------|-------------|--------------|-------------|--------------|-------------|--------------|-------------|--------------|-------------|
| SPEED<br>0.0 | MODE<br>4.2 | SPEED<br>0.0 | MODE<br>3.9 | SPEED<br>4.2 | MODE<br>3.0 | SPEED<br>3.3 | MODE<br>0.3 | SPEED<br>0.5 | MODE<br>0.0 | SPEED<br>3.3 | MODE<br>5.3 |
| Page 1       |             | Page 2       |             | Page 3       |             | Page 4       |             | Page 5       |             | Page 6       |             |

## 7.2. SETTING BY CLOUD SERVER OF WEBSITE

### 7.2.1. ACCESS STEPS ON WEBSITE

The Cloud server Web site: <https://cloud-3.seekway.cn>

Click the [+ Device] in the [Group management]. Enter the 24 characters in the ID bar and click [Confirm]



节点绑定

\* 节点ID:

\* Device:

Group na:

me:

| Parameter | Specification             |
|-----------|---------------------------|
| ID        | Enter the code of device. |
| Device    | The device's name.        |
| Group     | Group the device.         |

## 7.2.2. SETTING THE STATE BY CLOUD SERVER ON WEBSITE

After the controller is connected to the cloud platform, under the "\*\*\* Grouping" (such as project A) interface of "Node Status", check a controller (multiple selection supported) to remotely set the speed, brightness, animation, etc.



## 7.2.3. ADDRESSING BY CLOUD SERVER ON WEBSITE

1. Check the node in the Group \* of "Address" (multiple selection supported) to address it has drove the controllers.

Please make sure that SD card save with the addressing file.

2. After the address is complete, the Address Succeeded message is displayed on the node list.

The actual addressing success depends on the luminaire effect.



## 7.3. SETTING BY CLOUD SERVER OF PHONE

### 7.3.1. ACCESS STEPS ON THE PHONE

Use your mobile phone to log in to the operation interface.

Select "SY device" of "Device center". And then select "+添加节点" in the "节点列表".



Select the icon  to scan the UID code in the controller and select "确定".



### 7.3.2. SETING AND ADDRESSING BY CLOUD SERVER ON PHONE

After the controller is connected to the cloud platform, under the "\*\*\* Grouping" (such as project A) interface of "控制面板", check a controller (multiple selection supported) to remotely set the speed, brightness, animation, etc.

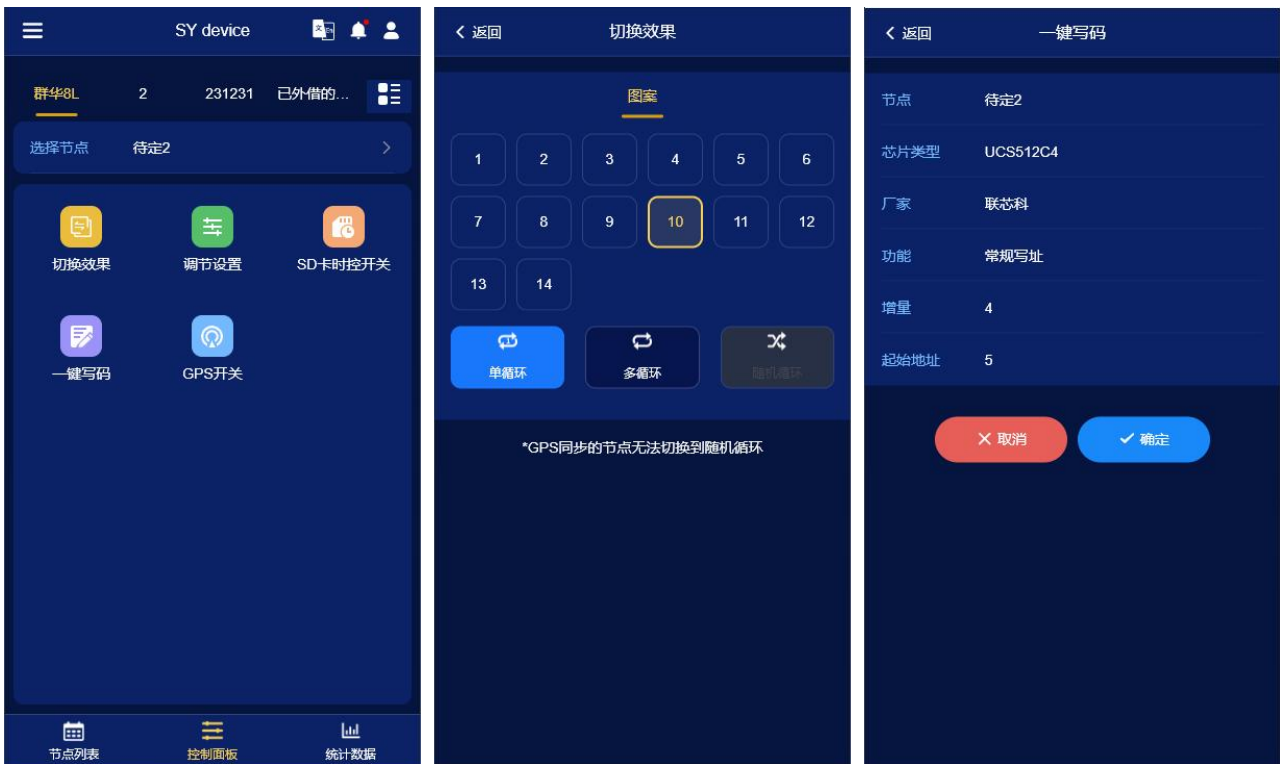

Parameter specification,

| Parameter | Specification  |
|-----------|--|
| 切换效果      | Select the animation to play. (Single[单循环], multiple loops[多循环] and random[随机] can be selected.)<br>When playing a single loop, you can click to select any effect to play.                                  |
| 调节设置      | 帧速, Set the number of frames per second (FPS) to play, ranging from 0.5 to 33 frames per second.<br>亮度, The values range from 0-100, where 100 is the brightest and 0 is all black.                          |
| 时控开关      | Enable or disable the SD time control function.  |
| 一键写码      | Select to address.<br><b>The coding result is judged by the display color of the lumaires.</b><br>The write parameters are automatically read from the SD card file and cannot be set on the cloud platform. |
| GPS 开关    | Enable or disable the GPS synchronization function.  |

## 8. OUTPUT AND COPY THE SD CARD FILE

### 8.1. OUTPUT THE SD CARD FILE

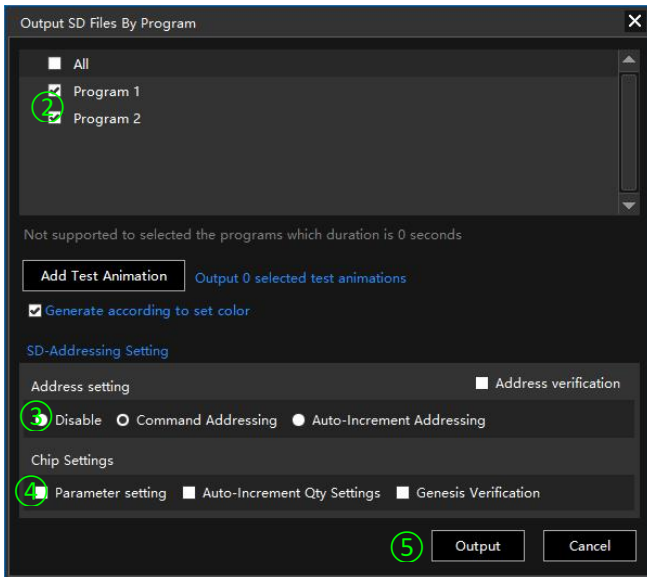

1. Click “SD” of Output, and open the windows.
2. Select the program be out-put. The total number of selected programs must be less than 96.
3. Select the addressing setting.
4. Select the chip settings.
5. Click Output.

Note: please don't select the addressing setting and chip settings if no address and parameters need to be set.

### 8.2. COPY THE SD FILE BY LED PLAYER

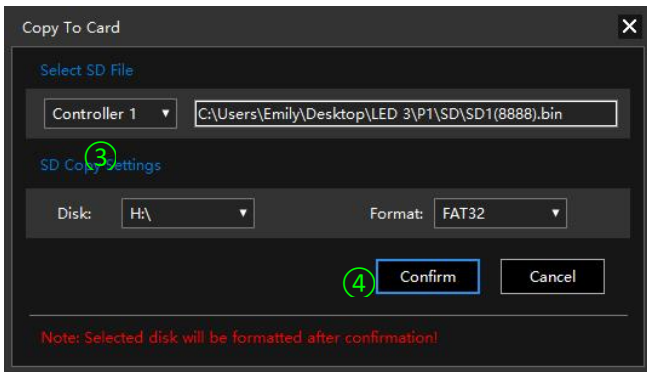

1. Input the SD card.
2. Click “Copy to SD” of Output, and open the windows.
3. Select the controller number be copied.
4. Click Confirm.

### 8.3. MANUAL FORMAT AND COPY CARD

1) Right click the disk where the SD card

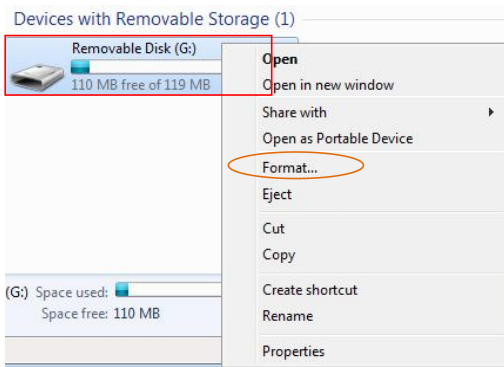

2) Select File system and 32KB (can check "Quick Format") and click START.

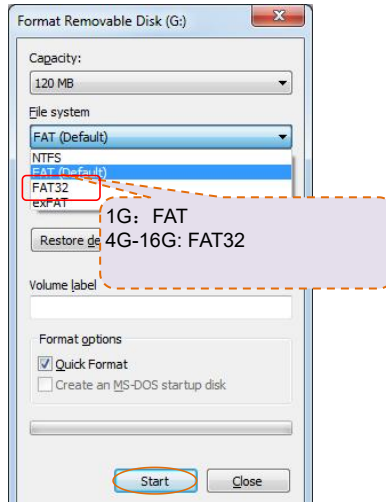

3) Right click SD1(8888).Bin file, send the file to removable disk.

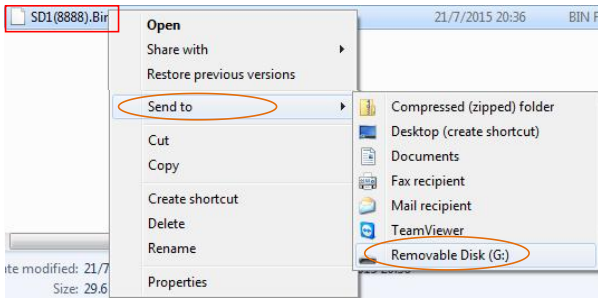

4) Right click removable disk and click "Eject".

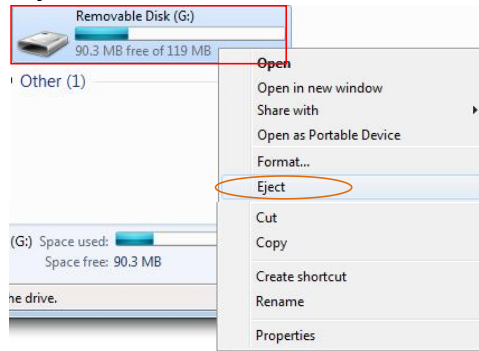







### 9. ERROR CODE

| Error     | Introduction  | Reason   |
|-----------|---|--|
| E01.xx.xx | No SD card.   | Poor seat connection. / No SD card.                                    |
| E02.xx.xx | SD card no response.                                    | Card is broken. / Card doesn't support read sequentially.              |
| E03.xx.xx | Cannot reset SD card.                                   | Card is broken. / Card doesn't support read sequentially.              |
| E05.xx.xx | Cannot read SD card.                                    | Cannot read part of the card. / Bad connection.                        |
| E07.xx.xx | SD card file sequence doesn't match the controller.     | SD card file error. / Unfinished video merging.                        |
| E18.xx.xx | The design of the program has exceeded its pixel limit. | Please reduce the program's total number of loaded pixels.             |
| E22.xx.xx | The firmware file is abnormal.                          | Please use the correct firmware file.                                  |
| E23.xx.xx | The firmware program is missing.                        | Please contact the after-sales service.                                |
| E24.xx.xx | The firmware upgrade failed.                            | Check whether the firmware is correctly upgraded and upgrade it again. |

| Error     | Introduction                        | Reason  |
|-----------|-------------------------------------|---|
| E27.xx.xx | The SD card has too many bad areas. | Replace the new SD card.  |
| E28.xx.xx | Slow response to card reading       | The SD card performance deteriorates.<br>Please replace the SD card with a new one. |

Description: The code is 6 digits. The first two digits are the fault code, and the last four digits are the subarea code to facilitate us to analyze the specific problem.

## 10. FITTINGS

| Shows   | Item                   | Number | Remark                |
|---|------------------------|--------|-----------------------|
|    | SD Card                | 1      |                       |
|    | 5P terminal            | 2      |                       |
|    | Straight screwdriver   | 1      |                       |
|    | Antenna stand          | 1      |                       |
|   | GPS antenna (3 meters) | 1      | GPS control fitting   |
|  | 4G antenna (3 meters)  | 1      | Cloud control fitting |