



# MQ-320 MANUAL

Version: 1.1.1

Model: MQ-320-A1

2024-11

# CONTENTS

1. FUNCTION OVERVIEW .....	1
2. TECHNICAL PARAMETERS .....	1
2.1. PRODUCT INFORMATION .....	1
2.2. INTERFACE SPECIFICATION .....	2
3. APPLICATION SOLUTION .....	2
3.1. DISENGAGES OUT OF CLOUD CONTROL .....	2
3.1.1. WORKING WITH A SINGLE SN DEVICE .....	2
3.1.2. MULTIPLE SN DEVICES WORK SYNCHRONOUSLY .....	3
3.1.2.1. LAN SIGNAL SYNCHRONIZATION WORK .....	3
3.1.2.2. GPS SIGNAL SYNCHRONIZATION .....	3
3.2. DISENGAGES FROM CLOUD CONTROL .....	4
3.2.1. A SINGLE SN DEVICE WORKED BY THE CLOUD PLATFORM .....	4
3.2.2. MULTIPLE SN DEVICES WORKED BY THE CLOUD PLATFORM .....	4
3.2.2.1. LAN SIGNAL SYNCHRONIZATION WORK BY CLOUD PLATFORM .....	4
3.2.2.2. GPS SIGNAL SYNCHRONIZATION WORK BY CLOUD PLATFORM .....	5
4. BASIC OPERATION .....	5
4.1. CONTROL PANEL .....	5
4.2. CONTROL SETTING .....	7
4.2.1. EFFECT .....	7
4.2.2. SPEED .....	8
4.2.3. LOOP .....	8
4.3. UNLOCK CONTROLLER .....	8
4.4. SHUTDOWN / RESTART .....	9
5. MENU SETTING .....	9
5.1. UPDATE PROJECT AND ANIMATION FILE LOCALLY .....	10
5.2. ADJUST BRIGHTNESS AND GAMMA .....	10
5.3. SUB-CONTROLLER SETTNCS .....	10
5.4. THEME .....	11
5.5. BASIC SETTINGS .....	12
5.5.1. LOCK SCREEN .....	12
5.5.2. REBOOT .....	13
5.5.3. UPDATE THE SOFTWARE VERSION .....	13
5.6. SYNCHRONOUS SETTINGS .....	13
5.7. TIME SETTINGS .....	13
5.8. SYSTEM MONITORING .....	14
5.9. VERSION INFORMATION AND UPGRADES .....	14
6. PROJECT INFORMATION .....	15
7. ADDRESSING .....	15
7.1. ADDRESSING OPERACTION .....	15
7.2. LIGHTING UP .....	16
8. DEBUGGING .....	17
9. TIME CONTROL .....	18
9.1. ENABLE TIME CONTROL .....	18

9.2. TIME CONTROL EDITOR .....	19
10. OUTPUT AND COPY .....	20
10.1. OUTPUT .....	20
10.1.1. OUTPUT PROJECT FILE .....	20
10.1.2. OUTPUT THE CONFIGURATION FILE .....	20
10.1.3. OUTPUT CLOUD CONFIGURATION FILE .....	21
10.2. COPY FILE TO SD CARD OR U DISK .....	21
10.2.1. COPY BY LED PLAYER .....	21
10.2.2. MAMUAL COPY .....	22
11. REMOTE OPERATION OF CLOUD CONTROL SYSTEM .....	22
11.1. DEVICE BINDING INTERFACE .....	22
11.2. MQ-320 CONNECTS TO THE CLOUD PLATFORM .....	23
11.3. SETTING BY CLOUD SERVER OF WEBSITE .....	25
11.3.1. DEVICE MANAGEMENT .....	25
11.3.1.1. GROUPING AND NODE MANAGEMENT .....	25
11.3.1.2. SET THE STATE BY CLOUD SERVER ON WEBSITE .....	26
11.3.1.3. ADDRESSING AND DEBUGGING .....	26
11.3.2. MATERIAL MANAGEMENT .....	27
11.3.2.1. UPLOAD AND MANAGE ANIMATION MATERIALS .....	27
11.3.2.2. AUDITING THE MATERIALS .....	28
11.3.3. PORGRAM DESIGNING .....	28
11.3.3.1. PRODUCE PROGRAM OF GROUP .....	28
11.3.3.2. PRODUCE PROGRAM OF STANDALONE DEVICE .....	29
11.3.3.3. DEBUGGING ANIMATION .....	29
11.3.4. SCENARIO .....	30
11.3.4.1. ADD SCENE PROGRAM (SCENE CHOREOGRAPHY) .....	30
11.3.4.2. SCENARIOS PREVIEWER .....	31
11.4. OPERATION BY CLOUD SERVER OF PHONE .....	31
11.4.1.1. SETING DEVICE AND DEBUGGING ANIMATION ON PHONE .....	31
11.4.1.2. ADDRESSING AND HARDWARE DEBUGGING ON PHONE .....	32
11.4.1.3. MORE (AUGITING AND CHART) .....	33
11.4.1.4. SCENE CONTROL .....	33
12. LOADING SPECIFICATION .....	34
13. OTHER CONSIDERATIONS .....	34

# 1. FUNCTION OVERVIEW

1. 10.4 inch LCD screen, capacitive touch.
2. The fourth generation Core CPU, temperature control fan cooling low power consumption.
3. The maximum load can reach 600,000 channels (including virtual number), and 400 EN units can be controlled.
4. Support video soft and hard decoding, improve performance. It can play 2K video (H264 encoded mp4).
5. Support timing control, with synchronization module can achieve multiple wireless synchronization, can be used for large-scale lighting projects.
6. Built-in 4G module, insert 4G traffic card (or through wired network) to achieve remote control, program update, equipment upgrade, etc.
7. Attached with professional effect production software, we can make any effect by ourselves.

# 2. TECHNICAL PARAMETERS

## 2. 1. PRODUCT INFORMATION

Screen type: 10.4 inch (Capacitive touch screen)

Resolution: 1024 \* 768

Loading capacity: 60W channels within the 25FPS. (See more LOADING INSTRUCTIONS.)

Available: up to 400 pcs

Storage capacity: DDR3L 1600 8G

Memory: MSATA 128G SSD

Operating system: Linux

Other ports: Serial port \* 2, Gigabit Ethernet port \* 2, USB 3.0 \* 2, USB 2.0 \* 2

Operating temperature: -20~65°C

Relative humidity: 10%-90%, no condensation at 40°C

Input voltage: AC 100-240V

Size: L340 \* W246 \* H67 (mm)

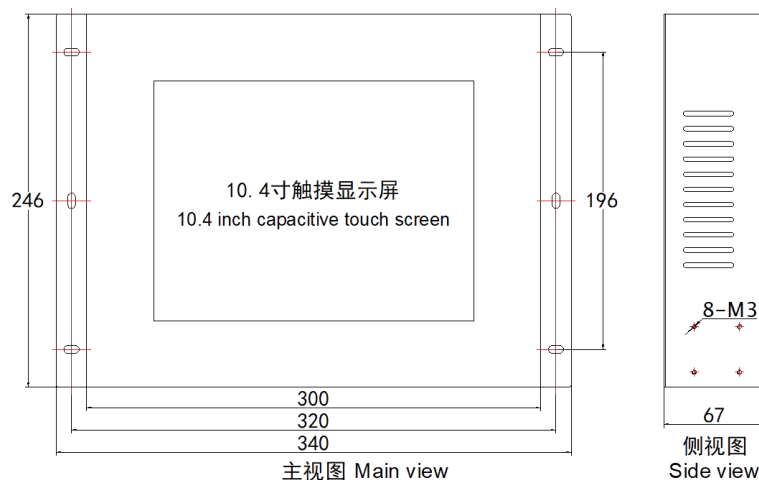

## 2. 2. INTERFACE SPECIFICATION

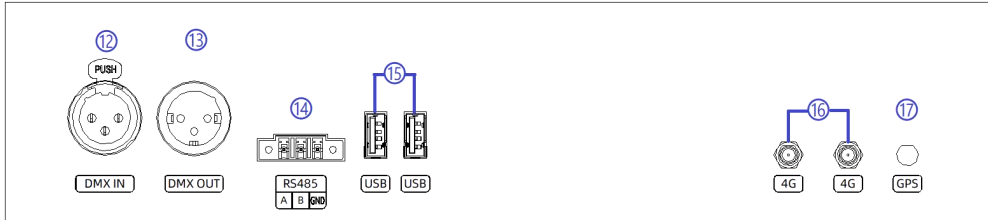
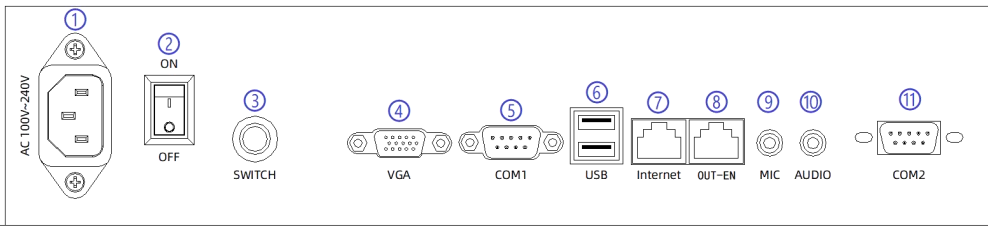

- |                         |                         |                      |
|-------------------------|-------------------------|----------------------|
| ① AC100-240V Power dock | ② Power switch (rocker) | ③ Push-button switch |
| ④ VGA                   | ⑤ COM                   | ⑥ USB 3.0            |
| ⑦ RJ45 (internet)       | ⑧ RJ45 (sub contrlller) | ⑨ Reserved           |
| ⑩ Reserved              | ⑪ COM                   | ⑫ Reserved           |
| ⑬ Reserved              | ⑭ RS-485 port           | ⑮ USB 2.0            |
| ⑯ 4G antenna interface  | ⑰ Reserved              |                      |

## 3. APPLICATION SOLUTION

### 3. 1. DISENGAGES OUT OF CLOUD CONTROL

#### 3. 1. 1. WORKING WITH A SINGLE SN DEVICE

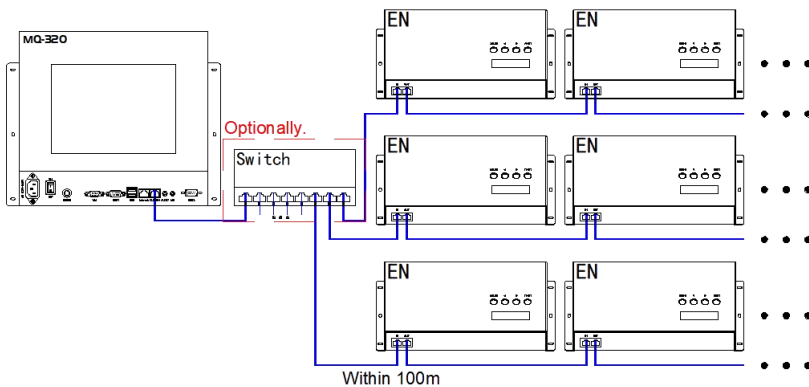

### 3.1.2. MULTIPLE SN DEVICES WORK SYNCHRONOUSLY

#### 3.1.2.1. LAN SIGNAL SYNCHRONIZATION WORK

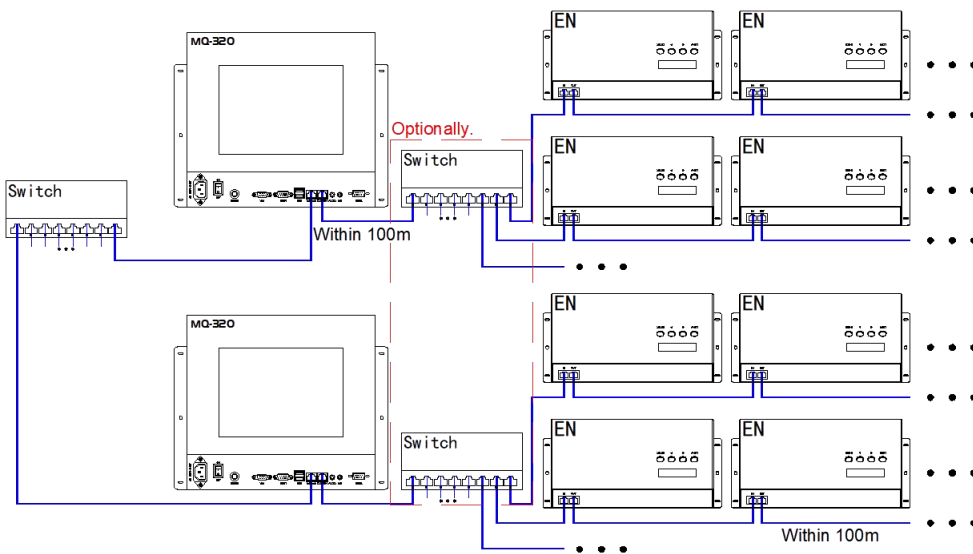

#### Note:

1. The switch must be used to synchronize the actual LAN between MQ-320 devices.
2. At the same time, all MQ-320 devices must enable the UDP synchronization mechanism. Configure one device to send synchronization signals and the other device to receive synchronization signals.

#### 3.1.2.2. GPS SIGNAL SYNCHRONIZATION

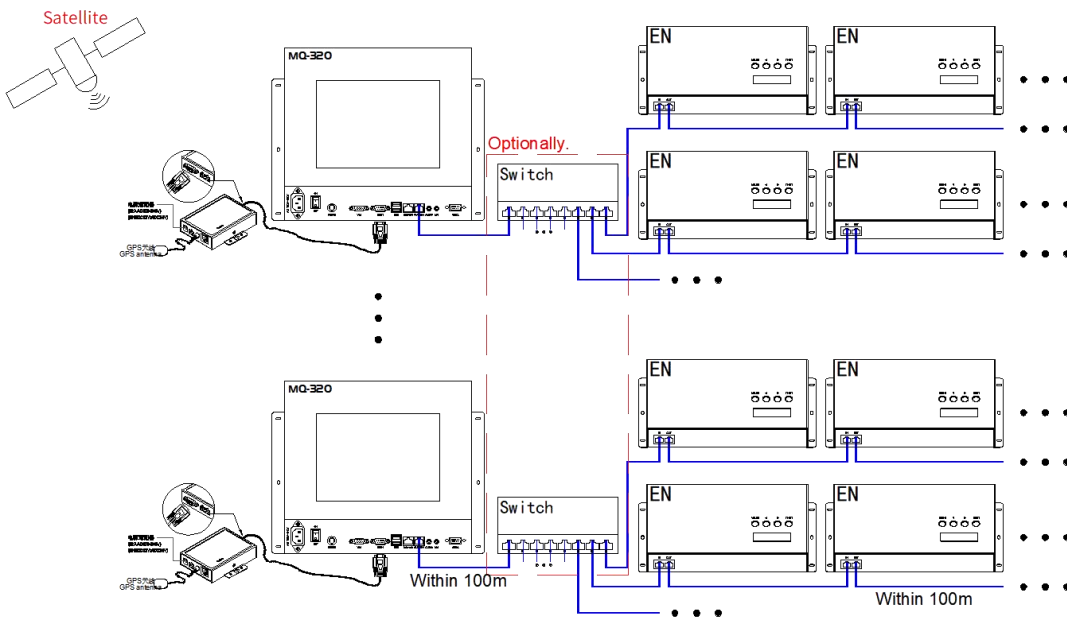

## 3. 2. DISENGAGES FROM CLOUD CONTROL

### 3. 2. 1. A SINGLE SN DEVICE WORKED BY THE CLOUD PLATFORM

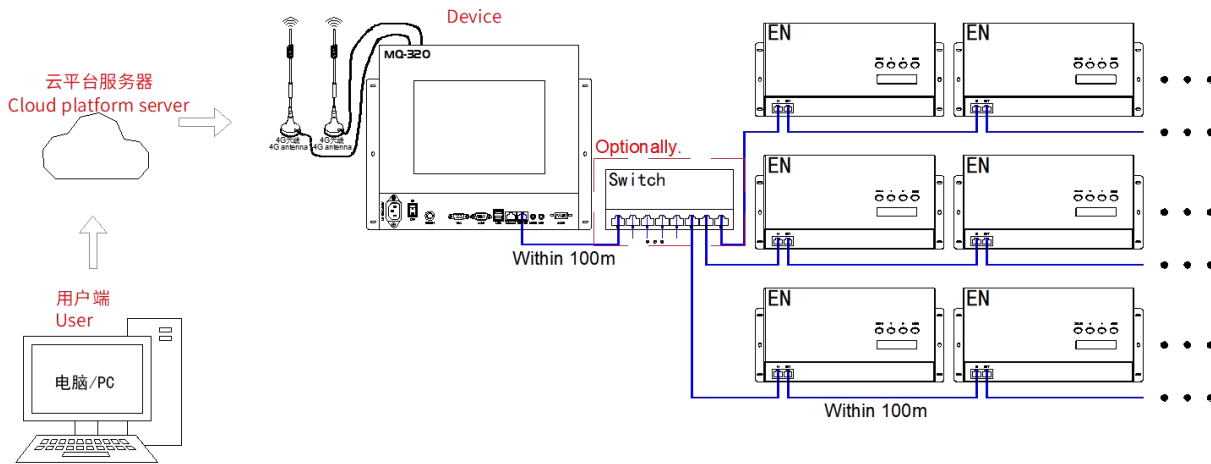

### 3. 2. 2. MULTIPLE SN DEVICES WORKED BY THE CLOUD PLATFORM

#### 3.2.2.1. LAN SIGNAL SYNCHRONIZATION WORK BY CLOUD PLATFORM

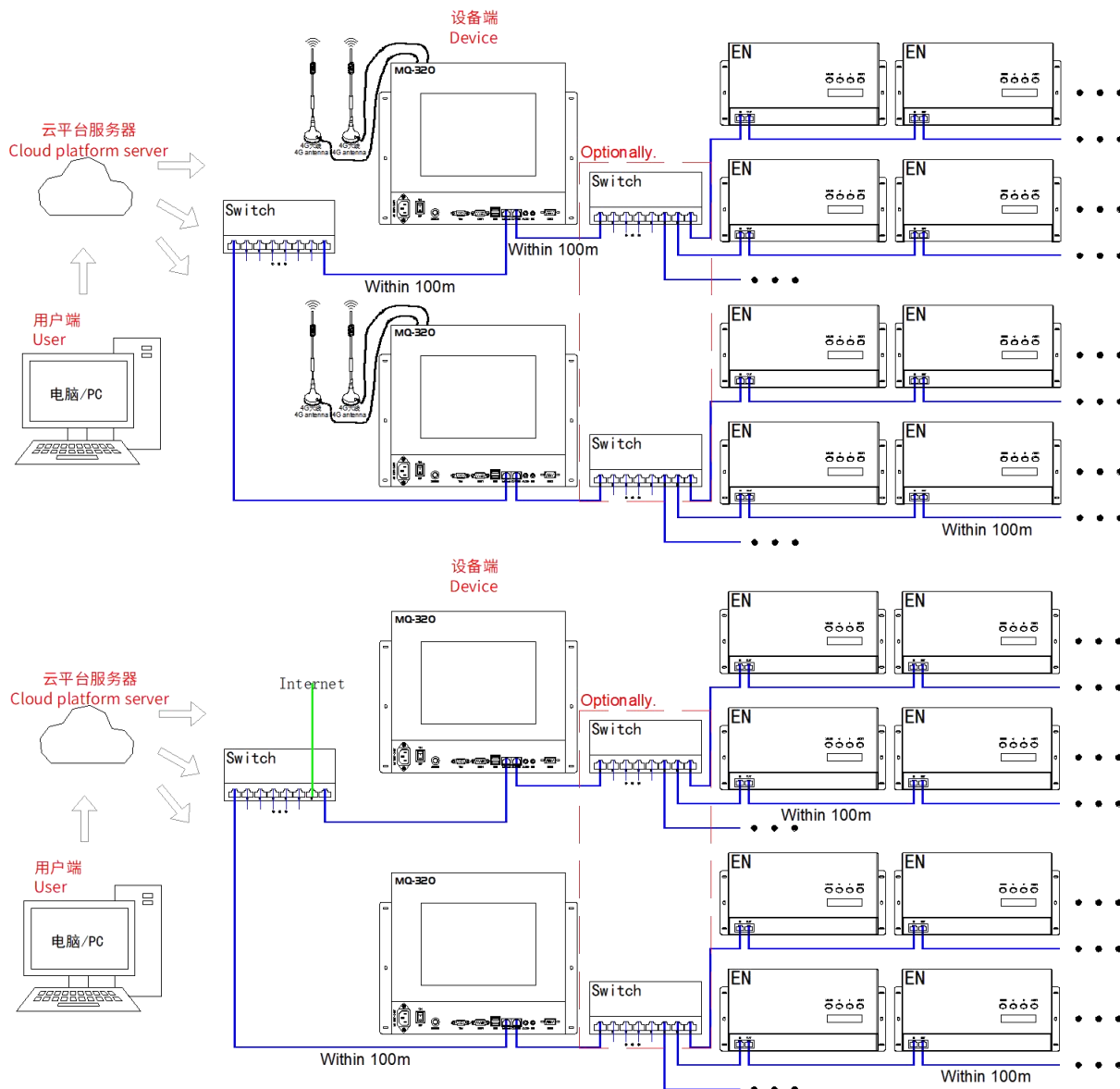

Note:

1. The switch must be used to synchronize the actual LAN between MQ-320 devices.
2. At the same time, all MQ-320 devices must enable the UDP synchronization mechanism. Configure one device to send synchronization signals and the other device to receive synchronization signals.

### 3.2.2.2. GPS SIGNAL SYNCHRONIZATION WORK BY CLOUD PLATFORM

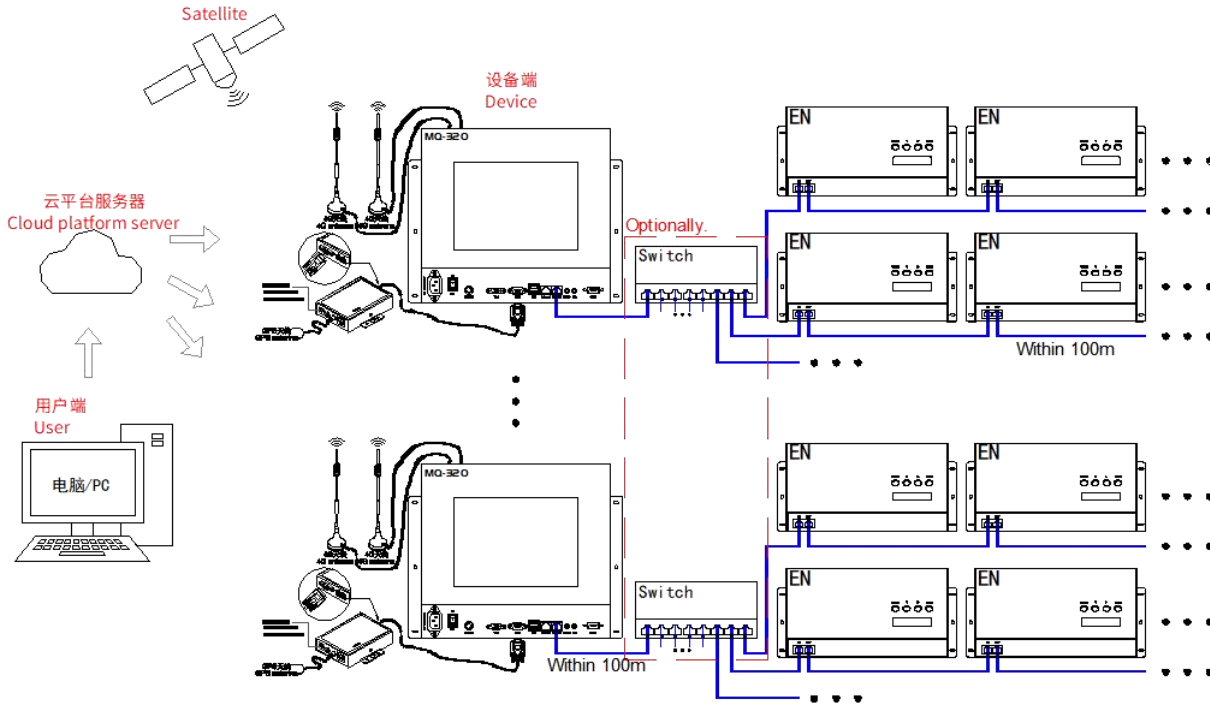

## 4. BASIC OPERATION

### 4.1. CONTROL PANEL

It is used to view the current playback status and device status.

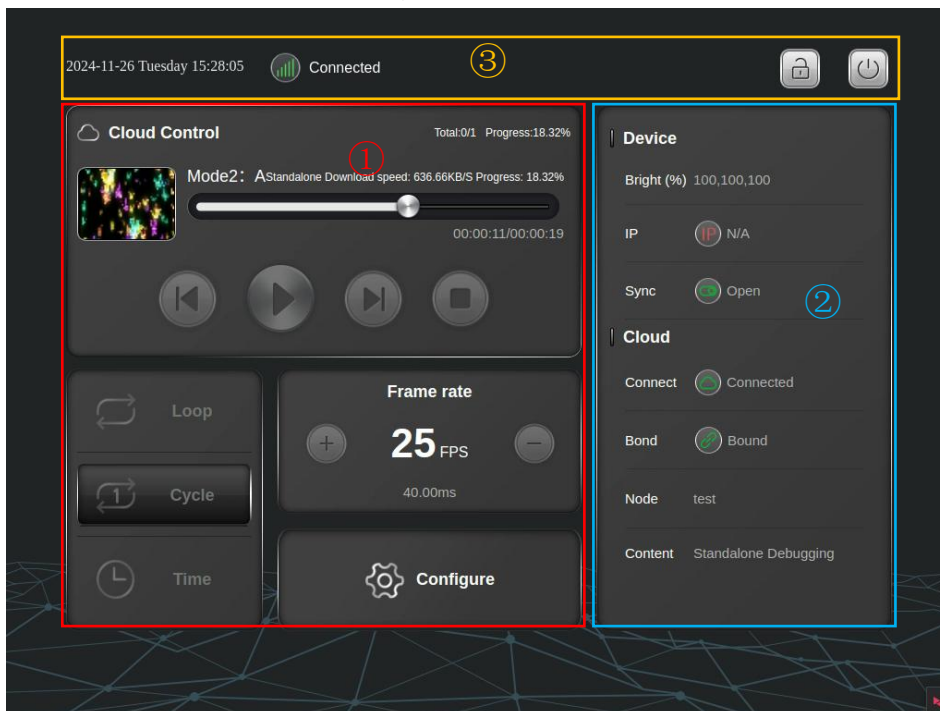

Note: Functions not supported or enabled by the controller are not displayed on the interface.



Icon		Function
① Control setting	Local control / List ** / Cloud control	Playback mode, includes Local control, Time control, Cloud control.
	Mode**:** 00:00:01/00:00:60	The mode number, effect name, effect preview, playback progress bar, and effect duration of the current playback effect.
	⏮ ⏪ ⏸ ⏹ ⏩ ⏭	Last program, next program, pause, stop, play. Display ⏸ in the playing state, display ⏹ in the paused or stopped state.
	↺ Loop / ↻ Cycle / ⌚ Time	Play mode, select to switch. ↺ Loop / ↻ Single loop / ⌚ Time broadcasting.
	Frame rate	Frame rate of the current playback, select ⊕ or ⊖ to adjustment.
	⚙️ Configure	Select to enter the function menu. For details about the functions, see PARAMETER SETTINGS.
② equipment info	Bright (%)	The brightness value of each channel of the current luminaire.
	IP	IP address of the network adapter connecting to the controller.
	Sync.	Status of the current synchronization switch.
	GPS	The strength of the GPS sync signal.
	外部检测	An external USB flash drive insertion prompt is detected.
	Cloud	If the cloud control function is enabled, the cloud control information is displayed. For details, see REMOTE OPERATION OF CLOUD CONTROL SYSTEM.
	Cloud Setting button	Select to enter to connect to the cloud control.
③ Topurple	2024-11-01 Friday 14:09:42	Current time.
	🔒	Select to enter the screen lock state and switch between lock and unlock.
	🔄	Choose to shut down and restart the program.

## 4. 2. CONTROL SETTING

### 4. 2. 1. EFFECT

Displays the status of the current playback effects information, and manually controls the playback of local playlists in real time.

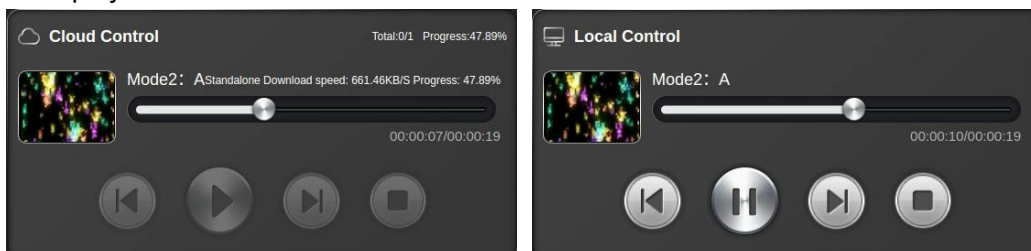

Icon	Control	Function
▶	Play	Select to play animation (program).
⏸	Pause	Select to pause play.
⏹	Stop	Select to stop.
⏮ ⏭	Previous / Next	Select the program to play, and the playback mode is automatically switched from loop playback to single playback.

**Attention:**

1. If MQ-320 is in the time-controlled or cloud-controlled playback state, the above control icon is grey and cannot be set. The current playback preview content can be viewed.
2. The program does not support the playback of music and algorithmic text materials.

### 4. 2. 2. SPEED

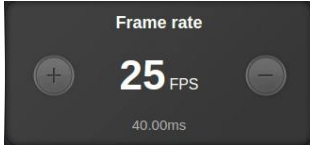

The smaller the number of frames per second (fps), the slower the effect will be. Select ⊕ and ⊖ to set the frame rate.

The frame rate is affected by the total number of lights controlled by MQ-320, the number of sub-controlled single-channel on-load pixels, chip type, pixels' position and other factors. Adjust to the actual engineering situation. Maximum frame rate reference range: 1-30FPS (1000-33.33ms)

### 4. 2. 3. LOOP

Select to switch. Loop / Cycle / Time.



Icon	Control	Function
	All loop	Once selected, loop back all animations from Mode1 in the current local playlist.
	Single loop	After selecting, repeat the current program of the local playlist.
	Time broadcasting	After selecting, it will enter the state of regular play program. For specific functions, see TIME CONTROL.

**Attention:**

1. If the playback mode is set Loop, the local playback starts from Mode1 while MQ-320 is powered on.
2. It cannot be set the play mode for cloud control.

### 4. 3. UNLOCK CONTROLLER

Select on the upper right corner to manually enable the lock screen function, and it enters the screen saver lock state.

Under the screen Lock status interface, select or double click anywhere on the screen to unlock and enter the control panel for normal operation.

If the password unlock screen is enabled, enter the correct 6-digit password in the pop-up window when unlocking the device. (The default password is 123456. For details about how to change the password, see BASIC SETTINGS.)

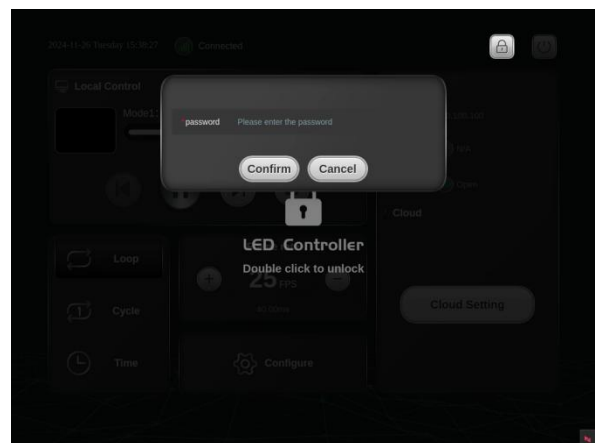
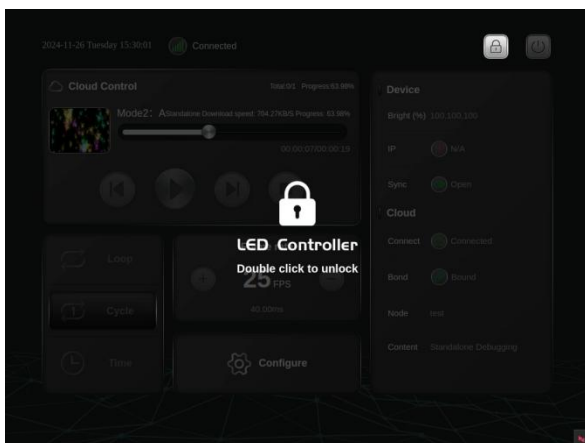

Lock

Enter password to unlock

## 4. 4. SHUTDOWN / RESTART

Select  to shut down or restart the device.

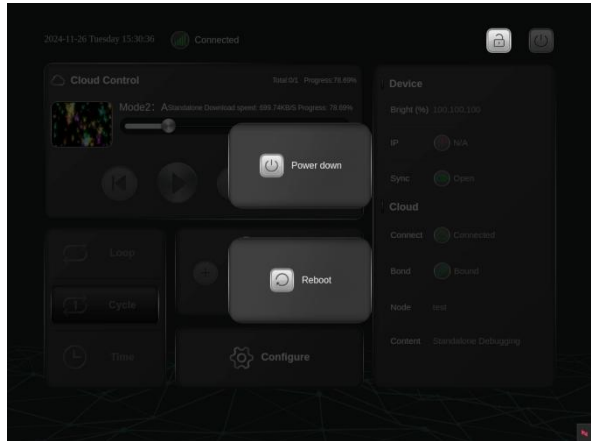
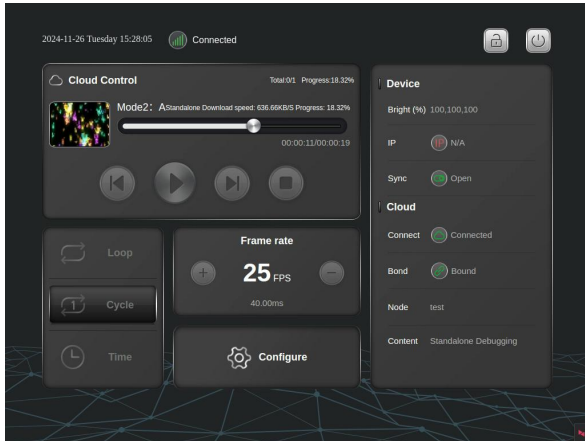

## 5. MENU SETTING

Select  "Configure" in the control panel to enter the function menu. Select "Configure" option to configure the relevant contents of the project or device.

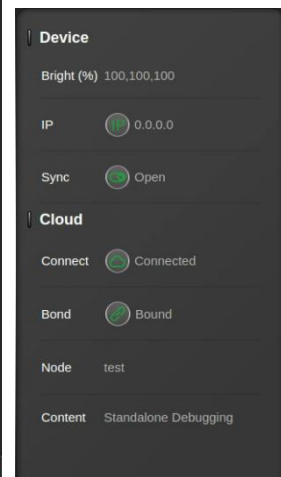
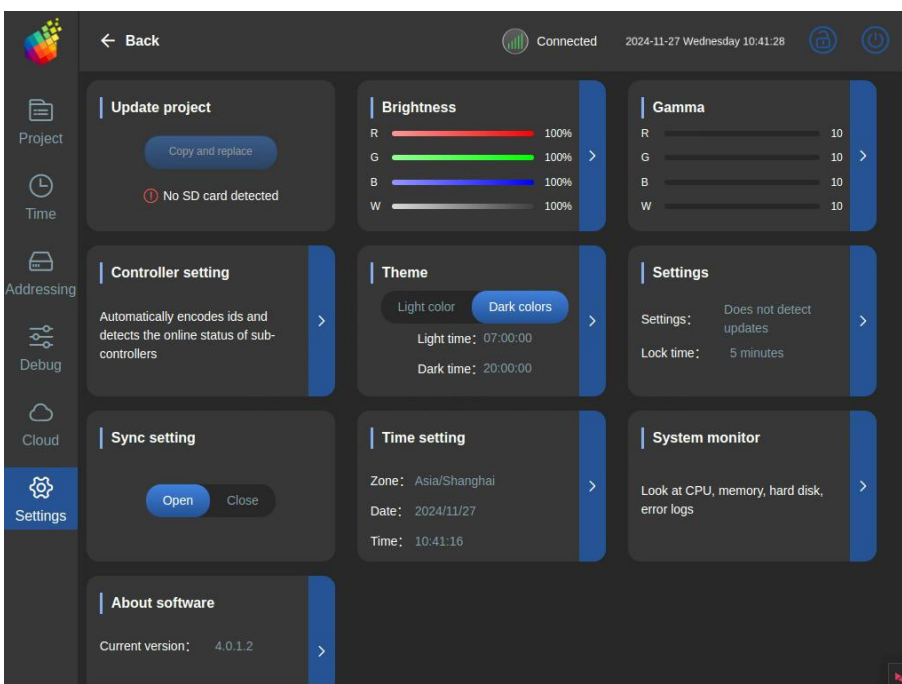
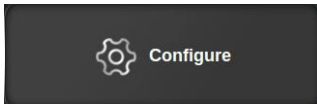

## 5. 1. UPDATE PROJECT AND ANIMATION FILE LOCALLY

After the engineering parameters and animation files are output and copied to the SD card or U disk as required (see OUTPUT AND COPY for details), the device interface displays “Do you want to update the project file?” We select “Update” to perform the update.

After the update is complete, MQ-320 automatically restarts. After the restart is normal, remove the SD card or USB flash drive.

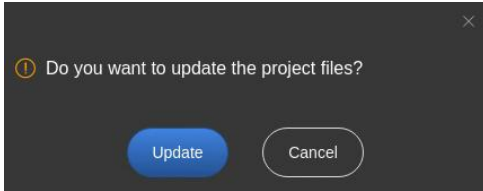

We can also select “Copy and replace” in the "Settings" option of the menu to update when it is clear that the device “SD card insertion with a profile was detected.”.

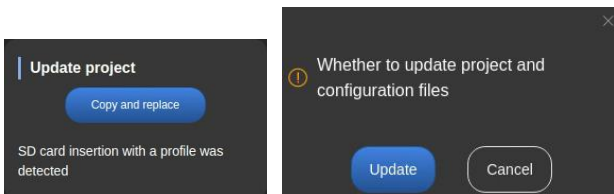

## 5. 2. ADJUST BRIGHTNESS AND GAMMA

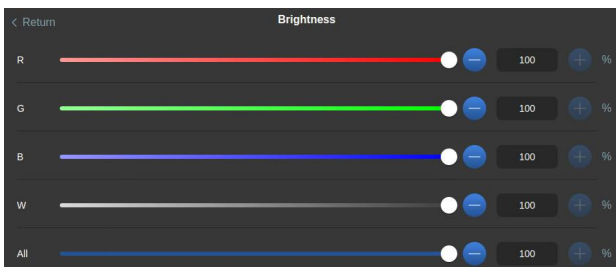
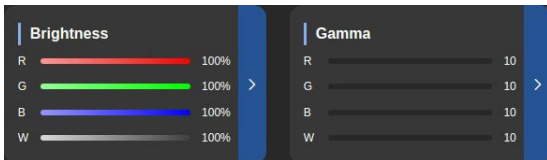

Select  on the right of “Brightness” under the Settings interface to set the brightness value of each channel for all programs.

Similarly, the gamma adjustment operation is the same.



## 5. 3. SUB-CONTROLLER SETTINGS

Can detect the online status of all access sub-controllers and configure ID codes for them in sequence with one click.

Select  on the right of “Controller setting” under the setting interface to click “ Check” under the pop-up window to obtain the online status of the project sub-control.

When all sub-controllers are online normally, we can enter the first ID code (ID code of the first sub-controller) and select “ Configure”. At this time, all the sub-controllers will write the ID code according to their own wiring sequence, starting from the first ID value and increasing by 1. The complete time is about 60-80 seconds.

**Note:**

1. During the process of writing the ID code by the sub-controller, if the control luminaire operation or the ID is set twice, the sub-controller may fail to write the ID.
2. If the device is in the cloud control state, this function cannot be enabled.

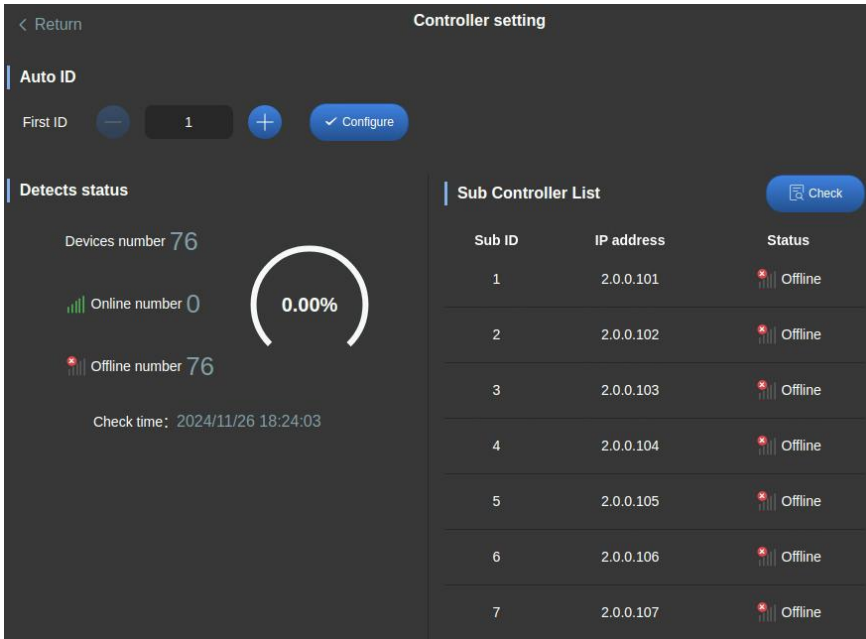
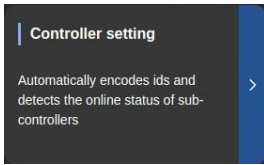

### 5. 4. THEME

Select  on the right of "Theme" under the setting interface to control the theme style of the interface. Themes can be fixed or periodically switched.

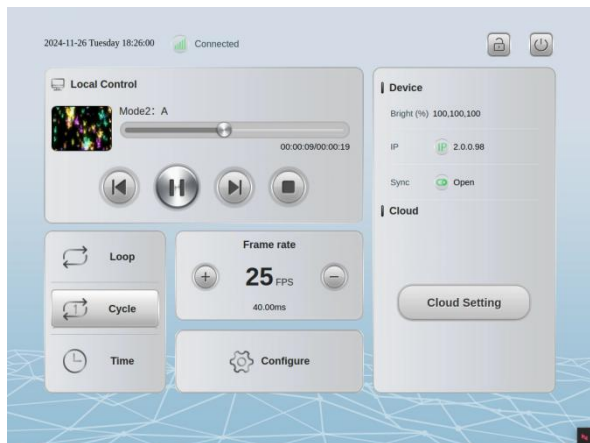
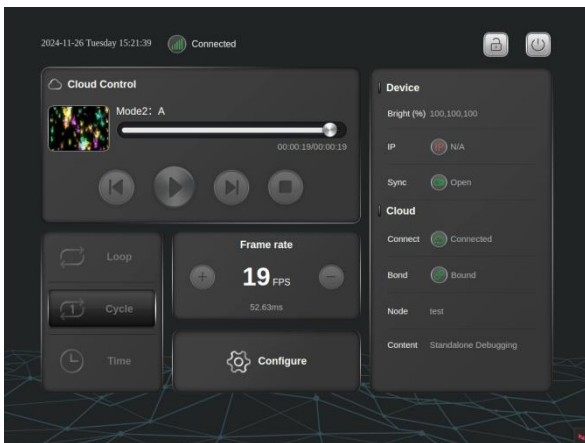
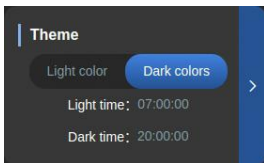

## 5. 5. BASIC SETTINGS

Select  on the right of “Settings” under the setting interface. And set the lock screen setting, scheduled restart, and version update under the pop-up window.

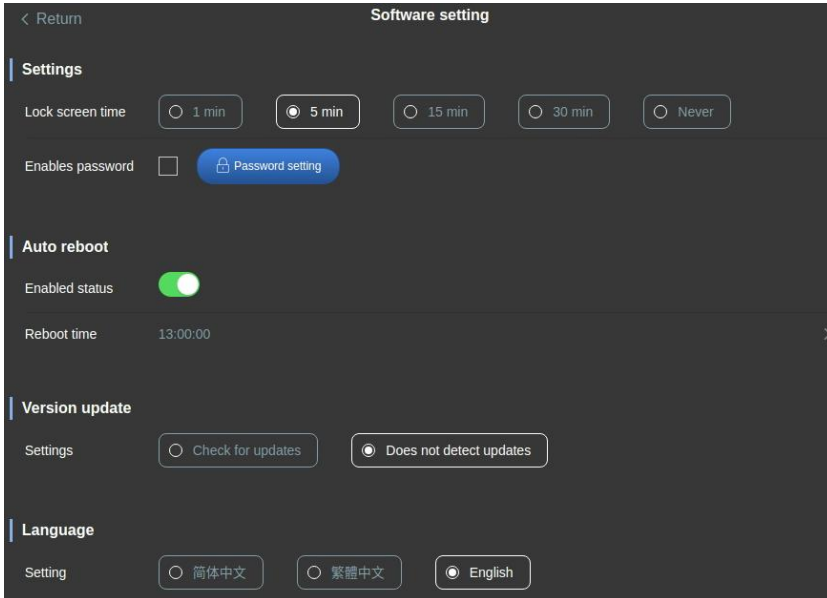
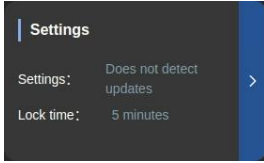

### 5. 5. 1. LOCK SCREEN

Set within a specified period of time, the screen automatically enters the lock protection interface if no operation is performed, in case of accidental touch. If we select “Never”, the automatic screen lock will not be performed. The system defaults to this option.

“Enables password”, to secure MQ-320, we can unlock it using a password. Check the Enable box and the default password is 123456. If we want to change the password, select “ Password setting” and enter the 6-digit password that needs to be set in the pop-up window.

**Note:** Please remember the password, otherwise the screen cannot be unlocked.

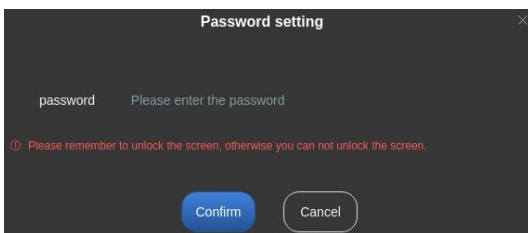
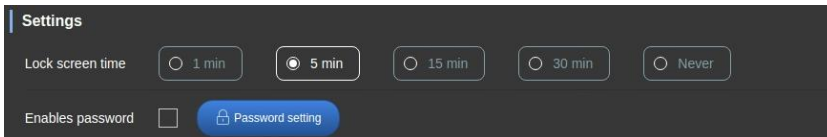

### 5.5.2. REBOOT

The device restart function can be set daily. By default, the device restart is enabled at 13:00 every day. The time can be changed.

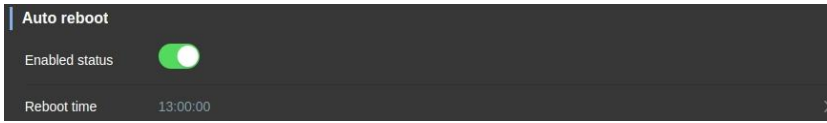

### 5.5.3. UPDATE THE SOFTWARE VERSION

“Check for updates”, after checking, the default network will pop up to prompt whether to update the latest version of the device program.

“Does not detect updates”, after checking, the device program version is not detected or upgraded after networking by default.

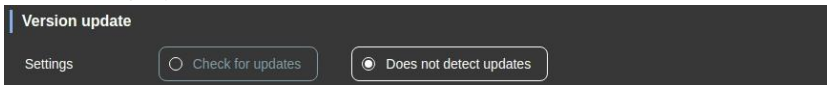

## 5.6. SYNCHRONOUS SETTINGS

Under the “Sync. setting” under the Setting interface, select “Open” or “Close” to turn on and off the synchronization function.

When enabled, we can view the signal strength of the device on the control panel. If the strength value is less than 9, the signal is weak and the icon turns red; if the strength value greater than or equal to 9, the signal is effective and the icon turns green.

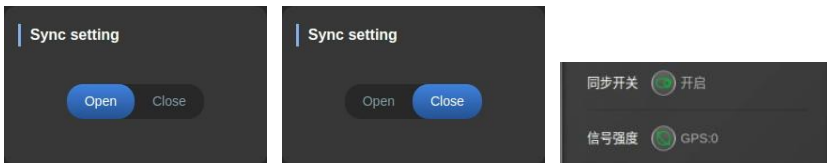

Instructions: This function requires all devices to be connected to GPS or BTS devices at the same time, and the same program and frame rate need to be set to achieve multiple synchronization.

## 5.7. TIME SETTINGS

Select  on the right of “Time setting” under the Setting interface to set the time zone and date and time.

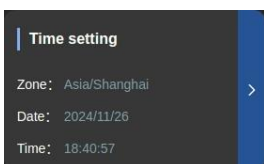

When the GPS synchronization function is enabled, the time and date are updated with the time data obtained by the GPS.

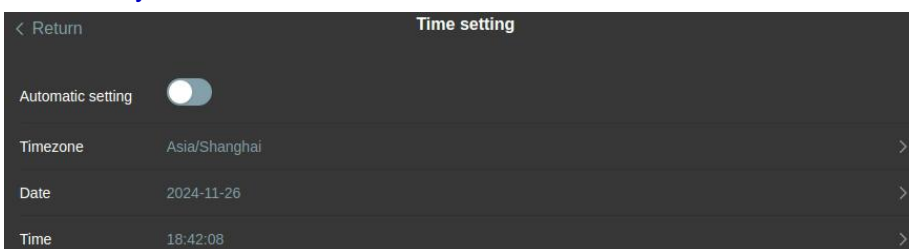

## 5. 8. SYSTEM MONITORING

Select  on the right of “System monitor” on the Settings screen to view the device running status.

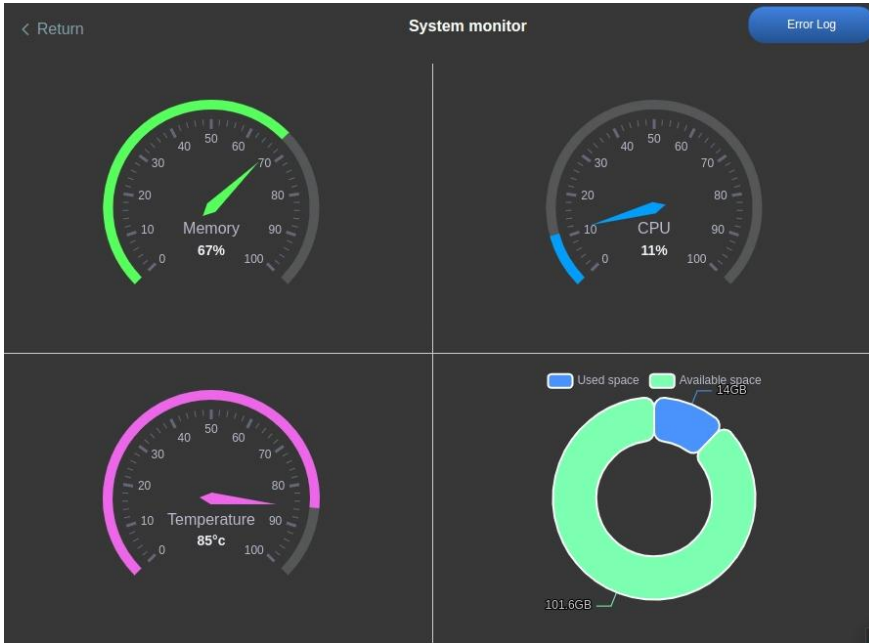

## 5. 9. VERSION INFORMATION AND UPGRADES

Select  on the right of “About software” under the Setting interface to view the software information in the open interface.

Manually upgrade the latest version:

If MQ320 is connected to the Internet, it will automatically detect whether the latest version can be upgraded and updated under the setting interface. If the NEW version is detected, the task bar of “Version upgrade New” will be displayed. Select and follow the prompts. If no, the taskbar is not displayed, indicating that the current version is the latest.

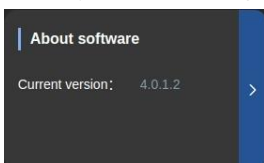

## 6. PROJECT INFORMATION

View project-related engineering information, including project name, project size, and hardware parameters of the controller, such as master model, sub-control model, drive pixels, active level, chip type, channel number, gray level, baud rate, channel sequence, etc.

On the menu page, Select “Project” in the left column to view.

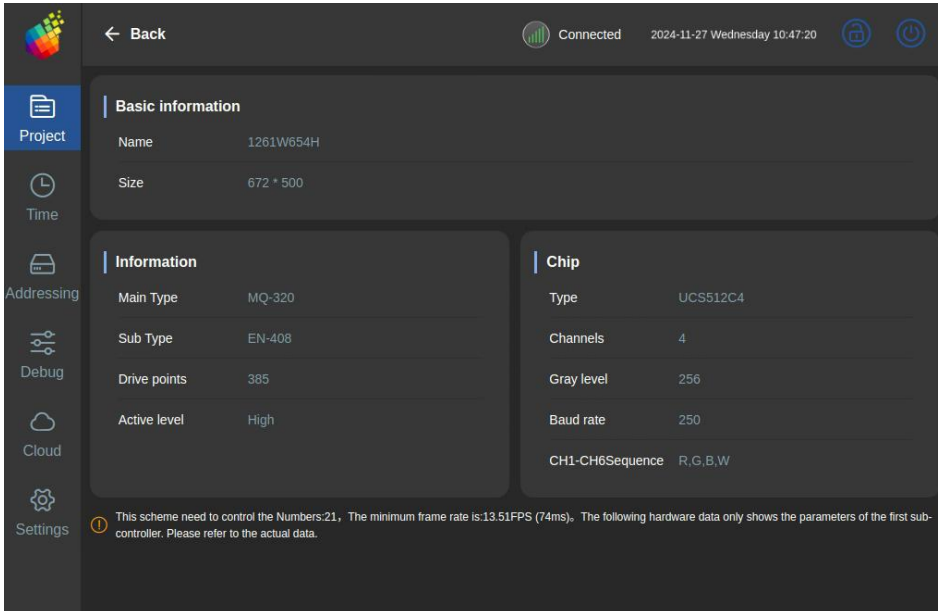

## 7. ADDRESSING

### 7. 1. ADDRESSING OPERATION

On the menu page, select “Addressing” in the left column to open the address operation interface.

**Note:** For the time being, only one-click addressing of all chips is supported. If there are some non-DMX chips under the project, this function will not be displayed/available.

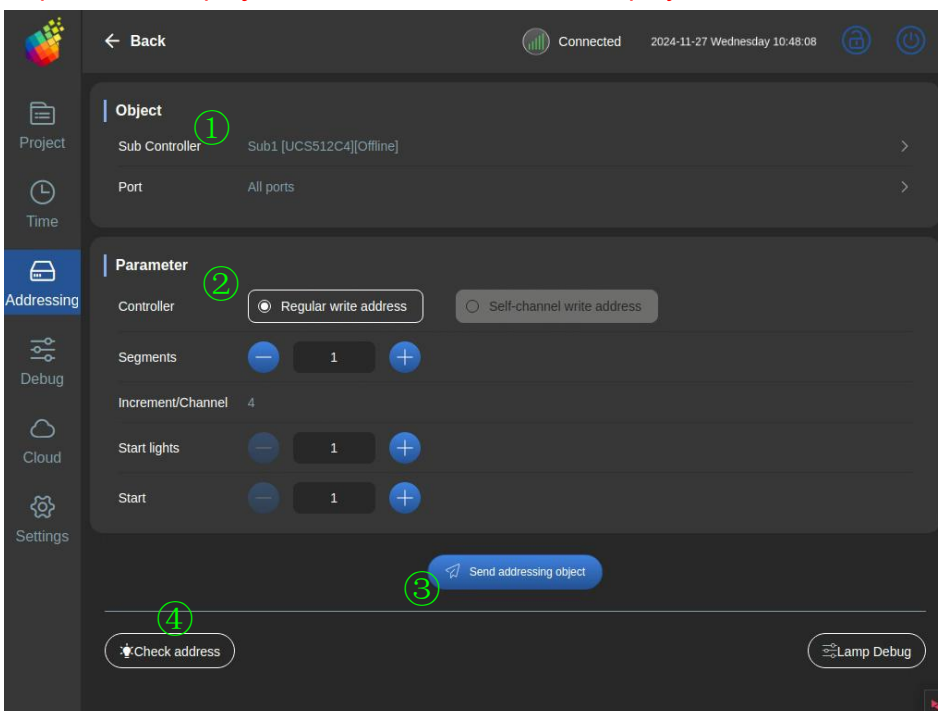

1. Select the addressing object.

Sub-controller: Select the controller which need to address.

[Online] Indicates that the controller is connected properly.

[Offline] Indicates that the controller will not be able to address the luminaires.

[Forbidden] Indicates that the driven chip is not DMX.

Port: Select the port to be addressed, optionally write all ports together.

2. Set the addressing parameters.

Controller (Address Mode): "Regular write address" and "Self-channel write address".

Segments: Sets the number of pixels driven by the selected chip.

Increment/Channel: Automatic calculation, manual setting is not supported.

Start lights: The number of luminaires that need to be addressed.

Start: Set the start address. Automatic calculation, manual setting.

3. Send write data.

Select "Send addressing object" to send the addressing parameters to all sub-controller.

Please ensure that the data of LED Player is consistent with the address of the actual luminaire. (It is recommended that the luminaire be addressed once before lighting up.)

4. Lighting up the chip to debug.

After the address is completed, we can select "Check address" to enter the light-up interface and check whether the address is correct. See LIGHTING UP for details.

If we want to debug the lighting on site and judge the luminaires and signal connection and transmission status, we can select "Debugging" to enter the debugging interface, see DEBUGGING for details.

## 7. 2. LIGHTING UP

In the "Addressing" interface, Select "Check address" to open the lighting operation interface.

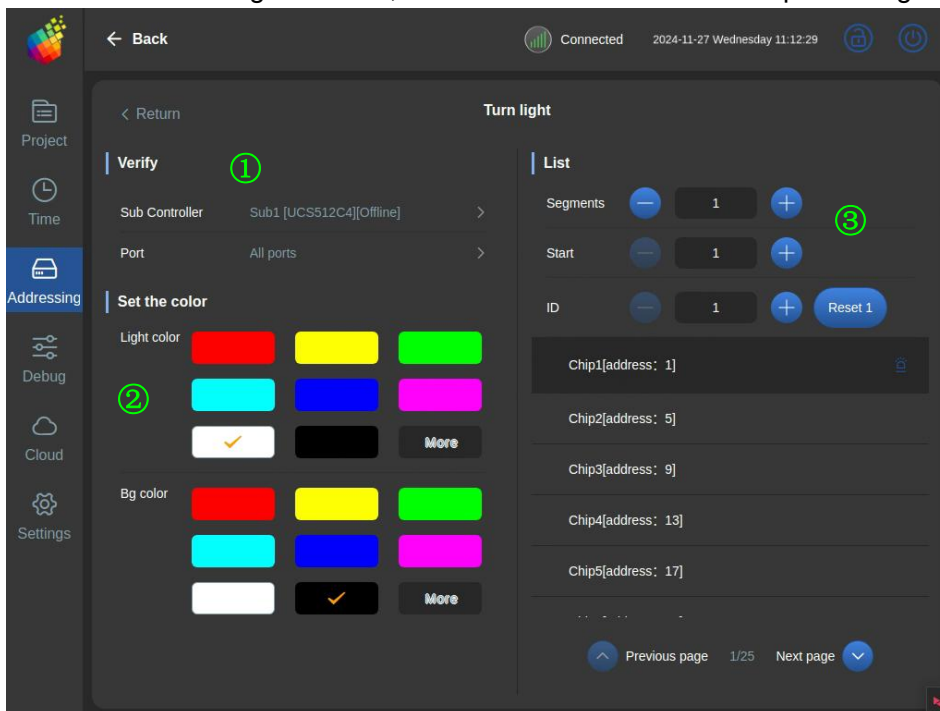

1. Select the checksum addressing object.

Sub-controller: Select the controller which need to check. Only one option is supported.

[Online] Indicates that the controller is connected properly.

[Offline] Indicates that the controller will not be able to address the luminaires.

[Forbidden] Indicates that the driven chip is not DMX.

Port: Select the port to be checked

2. Set the light or background color. By default, the background is all black.
3. Select the chip in the chip list.

Segments (Pixel): Sets the number of pixels driven by the selected chip.

Start: Set the start address. Automatic calculation, manual setting.

ID: The number of luminaires that need to be lighted up.

Please ensure that the data of the software is consistent with the actual luminaire address. If the consistency cannot be guaranteed, it is recommended to write the luminaire address once before lighting the luminaire. If the address data of the chip is inconsistent with the address of the actual luminaire, the lighting is also inconsistent with the required lighting.

## 8. DEBUGGING

Under the menu interface, select the “ Debug” tab to open the debugging operation interface.

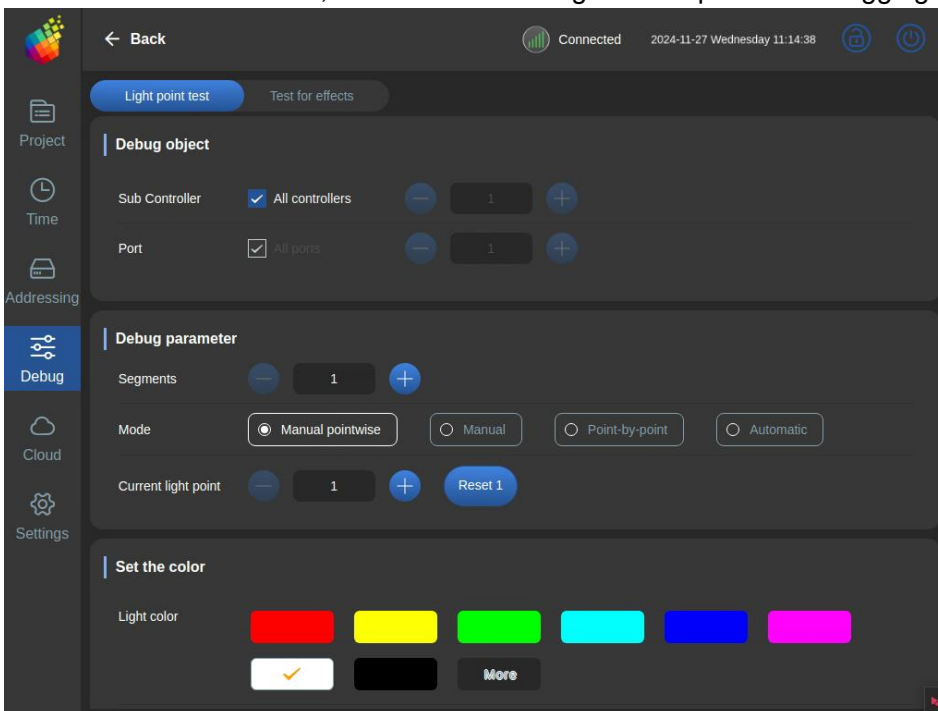

Step 1. Select the sub-controller and port that we want to debug.

Step 2. Select the test mode, “Light point test” can be lighted up by “Point wise” / “Piling up”; “Color” is the synchronous color running of the whole sub-control/port.

- A. The “Light pixel” needs to set the number of “pixels / segments” of the chip, “Mode” (the inspection method), and “point” (the lighting pixel) and “color”.
- B. “Screen” need to set the test effect type, effect speed, brightness.

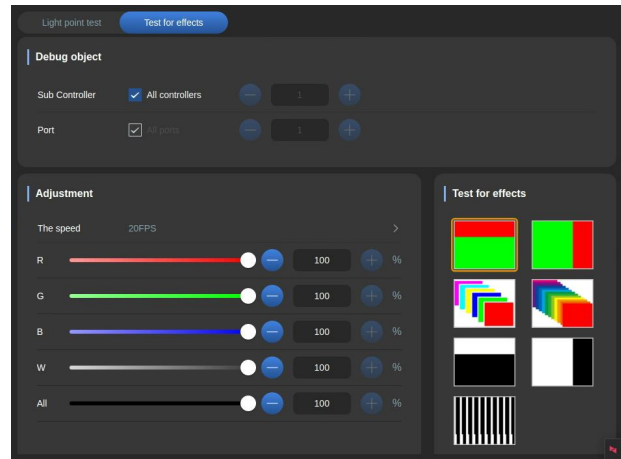
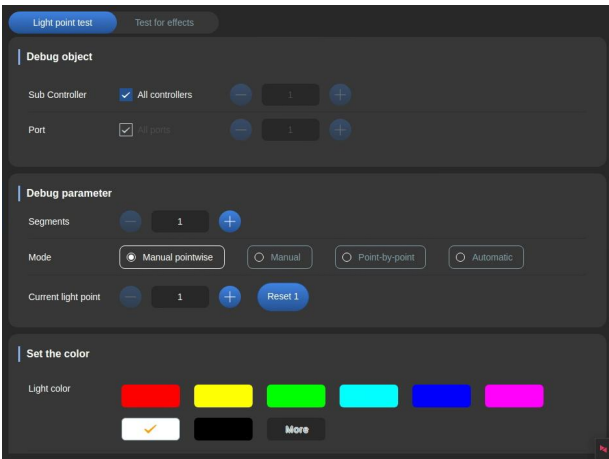

## 9. TIME CONTROL

### 9.1. ENABLE TIME CONTROL

It is necessary to copy the time control list information to the MQ-320 in advance, and select “⌚Time” on the control panel to set the specified effect of triggering playback within the specified time.

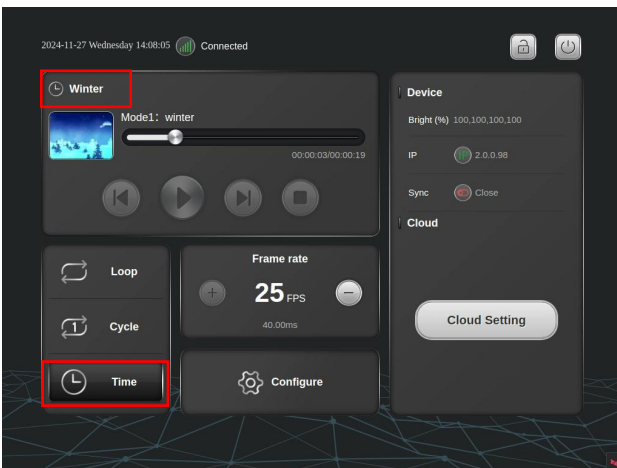

#### Enable the time control.

In the lower left corner of the "Control Panel" page, click “⌚Time” to enter the timing control state.

At the same time, the interface displays “⌚\*\*\*” (with clock icon), and the specified effect is set and run on time control list. When the time requirement is not met, the luminaire is in black state.

Click “↺Loop” or “↻Cycle” to restore the local normal playback state.

#### View and enable the time control information.

Select “⌚Time” under the menu interface to open the time control page, which displays the information of the time control list of the project.

The time control list can have multiple time periods to execute the same batch of programs. We can control the activation state of the entire time control list or a single time period. Select the time control  to . If a list (the right side of the name row is  disabled), even if the time under this list is  activated, the time control task will not be executed.

Select “👁View” to display the program content executed by the time control list.

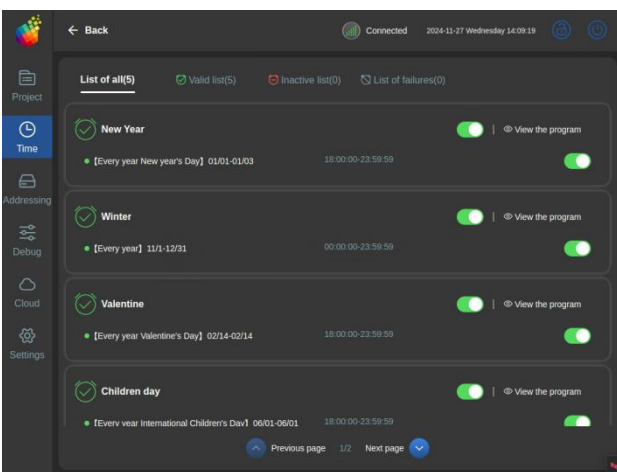



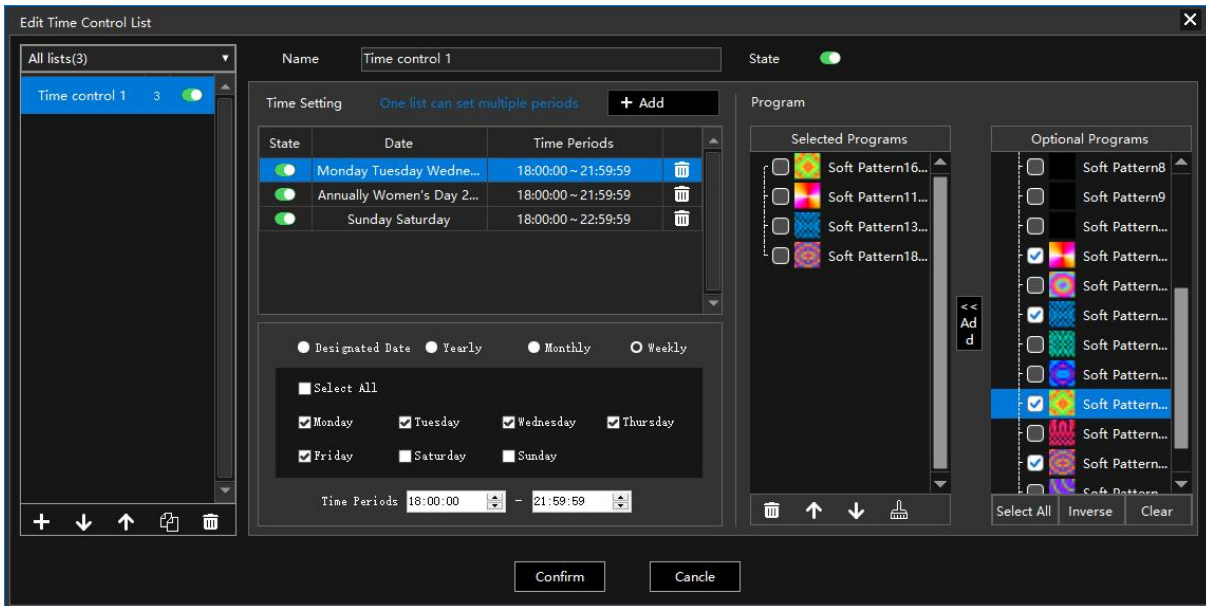

## 9. 2. TIME CONTROL EDITOR

On the computer, open the project through LED Player software, click  of the project property under the property list, we can open the edit time control list interface.



### 1. Editor

	Click to add a new list. / Click to delete selected list.
	Click to move the list position.
	Click to copy selected list.
List	Show the time control list. * Program ranking determines the ranking of time control list, that is, it represents the actual priority of time control. The higher the ranking, the higher the priority.
State	<input checked="" type="checkbox"/> Enable or <input type="checkbox"/> disable the list / program.
+ Add	Click to add a new time information.
Date	Set the time, Offers year, month, day, festival and other options
Time Periods	Sets the time when the specified program needs to be played.
Program	Select the program from the Optional to the Selected.
	Clear all selected programs.
Confirm	Click to save.

### 2. Output the time control information.

If the setting is complete, the project file must be re-output and updated to MQ-320 (the total number of time controllers cannot exceed 96), the output file is detailed in OUTPUT PROJECT FILE.

# 10. OUTPUT AND COPY

## 10.1. OUTPUT

### 10.1.1. OUTPUT PROJECT FILE

Output all configuration parameters and animation material parameters in the project by the LED Player, including hardware configuration, material files, and material parameters.

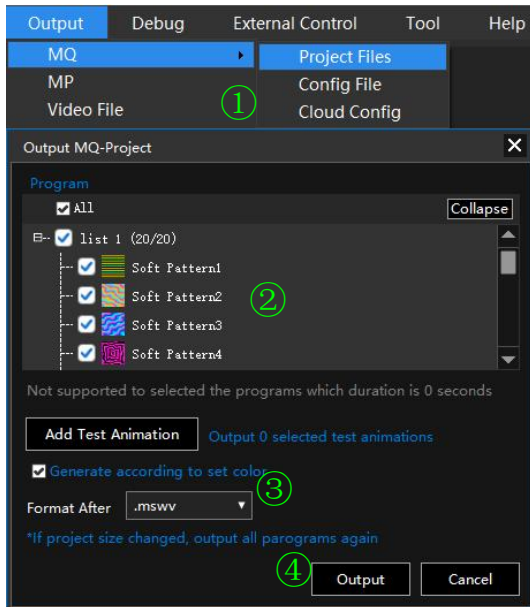

- ① Click Output → MQ → Project Files successively to open the output window.
- ② Select the program file to be output.
- ③ Select the output program file format, support “.MSWV” format and “.mp4” format files.
- ④ Click Output and wait for the output to complete. It will output an MQ folder (including RGB folder and SET folder) in the project folder.
- ⑤ We can insert U disk or SD card as prompted to copy the MQ folder, or refer to MAMUAL COPY to copy files.

Explain,

- A. If the project size is modified, all programs need to be output “.mswv” format file again; otherwise, the playback will be abnormal.
- B. The “.mp4” video does not support the lighting need to present 4/5/6 channel Settings.
- C. MQ-320 only supports videos less than 2K, and 4K videos need to be converted to their own formats.
- D. It does not support playing music and algorithm text effect.

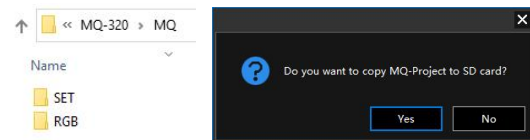

### 10.1.2. OUTPUT THE CONFIGURATION FILE

Only output the hardware configuration parameters of the project.

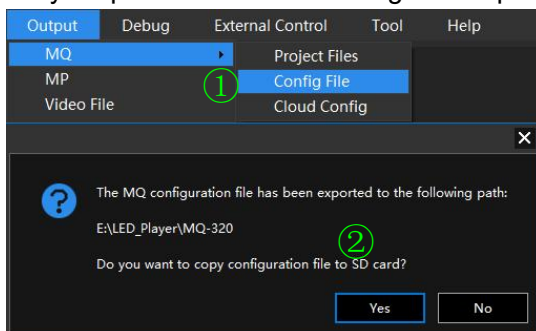

- ① Click Output → MQ → Config File successively to generate the configuration file. There is a folder named SET in the MQ folder of project.
- ② We can insert U disk or SD card as prompted to copy the MQ folder, or refer to MAMUAL COPY to copy files.

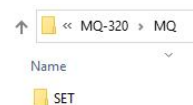

### 10.1.3. OUTPUT CLOUD CONFIGURATION FILE

Generate the cloud control configuration file, so that the cloud platform can be uploaded to realize the network update program.

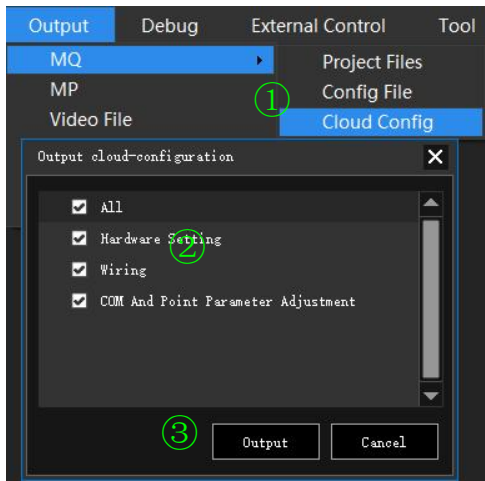

- ① Click Output → MQ → Cloud Config successively.
- ② Select the required configuration information.
- ③ Click Output.
- ④ Output a compressed file package of "cloud\_config" in the project folder. We can update it online after cloud control upload. For details about uploading, see GROUPING AND NODE MANAGEMENT.

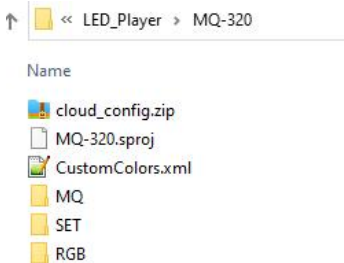

## 10.2. COPY FILE TO SD CARD OR U DISK

### 10.2.1. COPY BY LED PLAYER

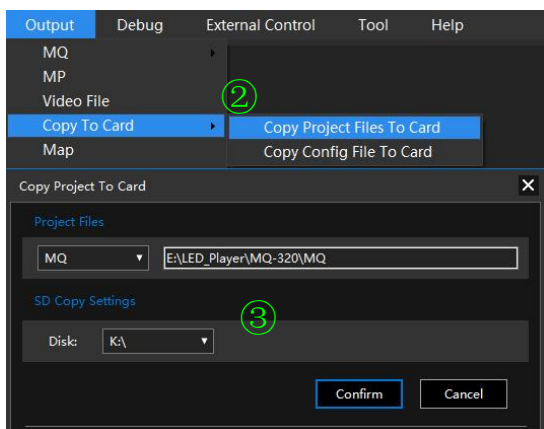

- ① Insert an SD card or U disk.
- ② Click Output → Copy To Card → Copy Project File To Card of the software successively to open the copy card window.  
(To copy the configuration file, select Copy Config File To Card.)
- ③ Select the corresponding drive letter and click Confirm.

## 10.2.2. MANUAL COPY

Insert the SD card/U disk and copy the files to it by following the steps below.

### 1. Copy the project file (including SET and RGB folder).

- 1) Open the "MQ" folder in the project file.
- 2) Multiple "RGB" folder and "SET" folder, and right-click.  
(Do not change the folder name, to avoid MQ-320 can not write correctly.)
- 3) Select "Send to" USB Drive in the pop-up window and wait for the copy.
- 4) After completion, right-click the U disk and select "Eject" to complete the entire operation.

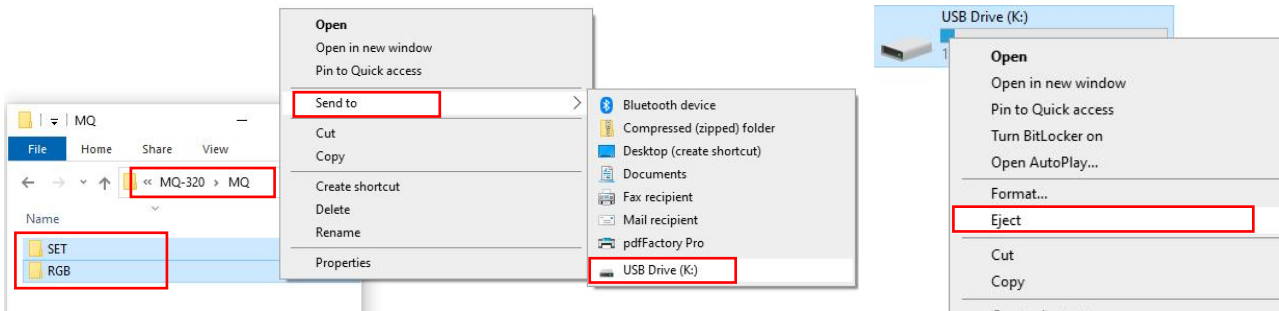

### 2. Copy the configuration file.

- 1) Open the "MQ" folder in the project file.
- 2) Right-click the "SET" folder and select "Send to" USB Drive.
- 3) After completion, right-click the U disk and select "Eject" to complete the entire operation.

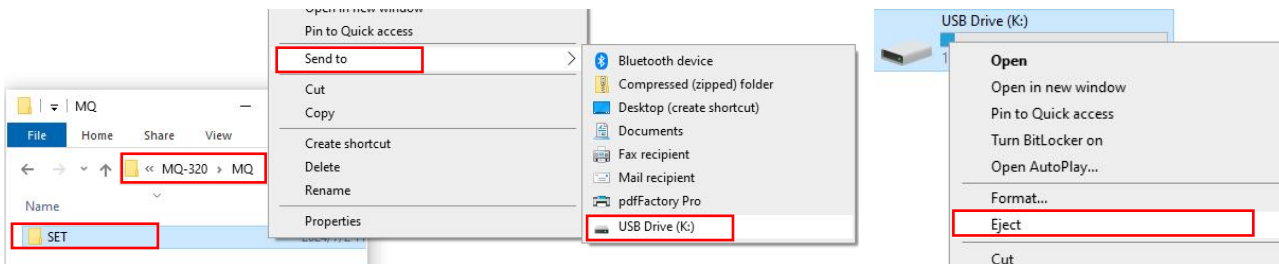

## 11. REMOTE OPERATION OF CLOUD CONTROL SYSTEM

### 11.1. DEVICE BINDING INTERFACE

Select "Cloud setting" in "Control Panel", or click "⚙️ Configure" → "☁️ Cloud" successively to enter the cloud control setting page.

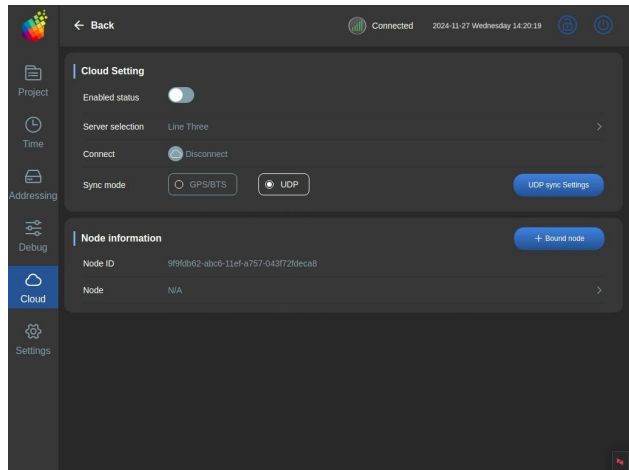
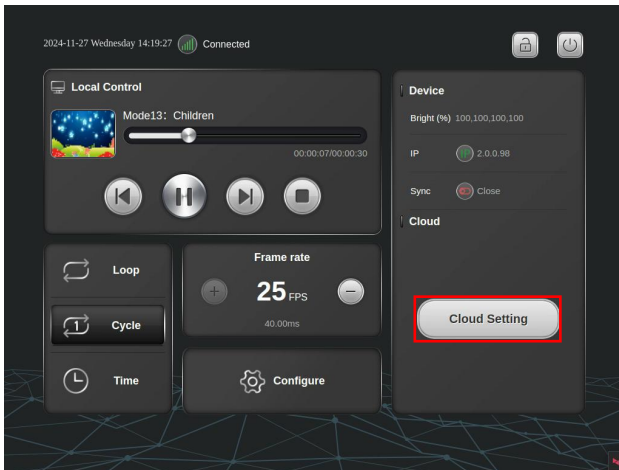

## 11.2. MQ-320 CONNECTS TO THE CLOUD PLATFORM

1. Get the connect code.

Method 1. Click the website: <https://cloud-3.seekway.cn>, bind the device to the project for the convenience of overall/group control. Under "Group Management" - "\*\*\* Group" (such as item A), click "+ Device". Get a six-digit verification code.

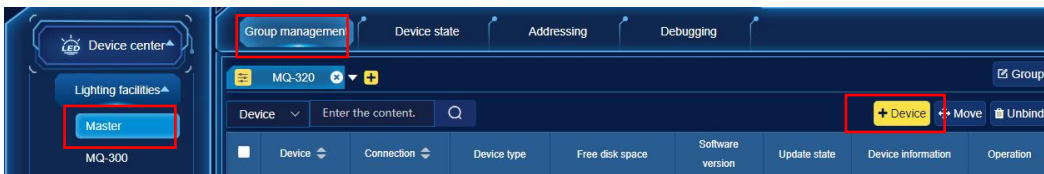

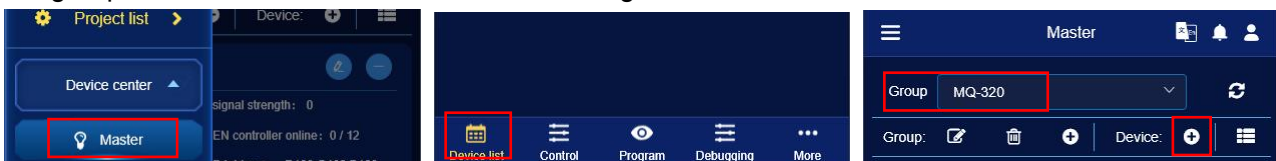

Method 2, select "Device center" - "Master" in the mini program interface, under "Device list", select the group and click "+" on the side of "Device" to get the verification code in the window.

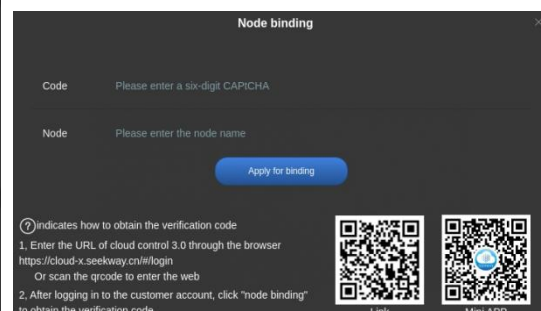
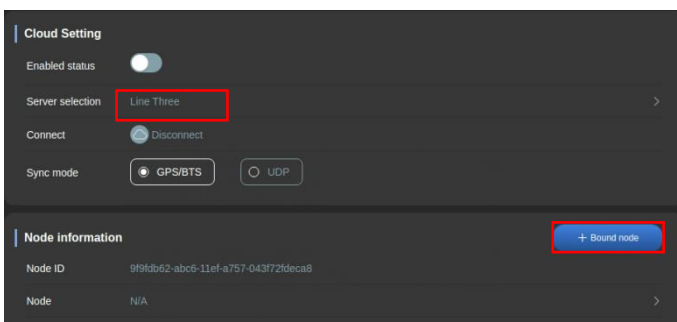

2. On the "Cloud" interface of MQ-320, ensure that the server is in the "Server 3" state, click "+ 绑定节点" (Binding), enter the six-character verification code and name in the pop-up window, and click "申请绑定" (Apply).



3. After binding, the device displays “ Connected” and “ The node is bound to the project”. At the same time, the status of its access to the cloud control displays on the control panel.

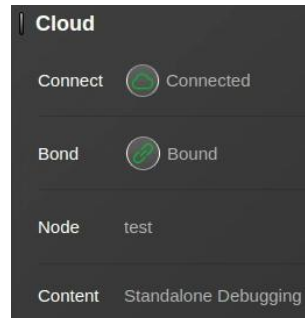
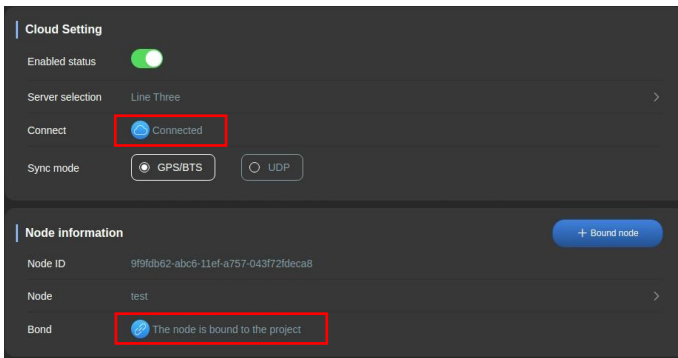

We can select the GPS/BTS or UDP synchronization mode based on the application requirements of the project.



When using UDP synchronization time, we need to set the synchronization parameters.

Select "UDP settings", the requirements are,

- ① All devices must be on the same LAN.
- ② Only one host can be configured on one LAN.
- ③ The number of frames and the number of files of the effect need to be consistent.

### 11.3. SETTING BY CLOUD SERVER OF WEBSITE

The Cloud server Web site: <https://cloud-3.seekway.cn> Enter the correct login account and password, and log in. We can perform all the following cloud control operations.

**This manual is only a simple operation guide. For detailed operation, please see our [SEEKWAY\\_CLOUD\\_3.2\\_OPERATION](#).**

#### 11.3.1. DEVICE MANAGEMENT

##### 11.3.1.1. GROUPING AND NODE MANAGEMENT

Under the interface of "Device center" - "Lighting facilities" - "Master" - "Group management",

- 1) Click to add a new group.
- 2) Click Group to modify the group name.
- 3) Click Device to obtain the verification code again to bind the device.
- 4) After selecting the devices, click Move to group the selected devices.
- 5) Click Unbind to remove cloud control from the device to be selected.
- 6) Click "Update" under the device information box to upload "Cloud\_config.zip" and update the program of the project. Obtain "Cloud\_config.zip" refer to Outputting Cloud Configuration.
- 7) Click "View" to see the sub-control and lighting information of the equipment.
- 8) Click "Edit" to modify the name and regroup.

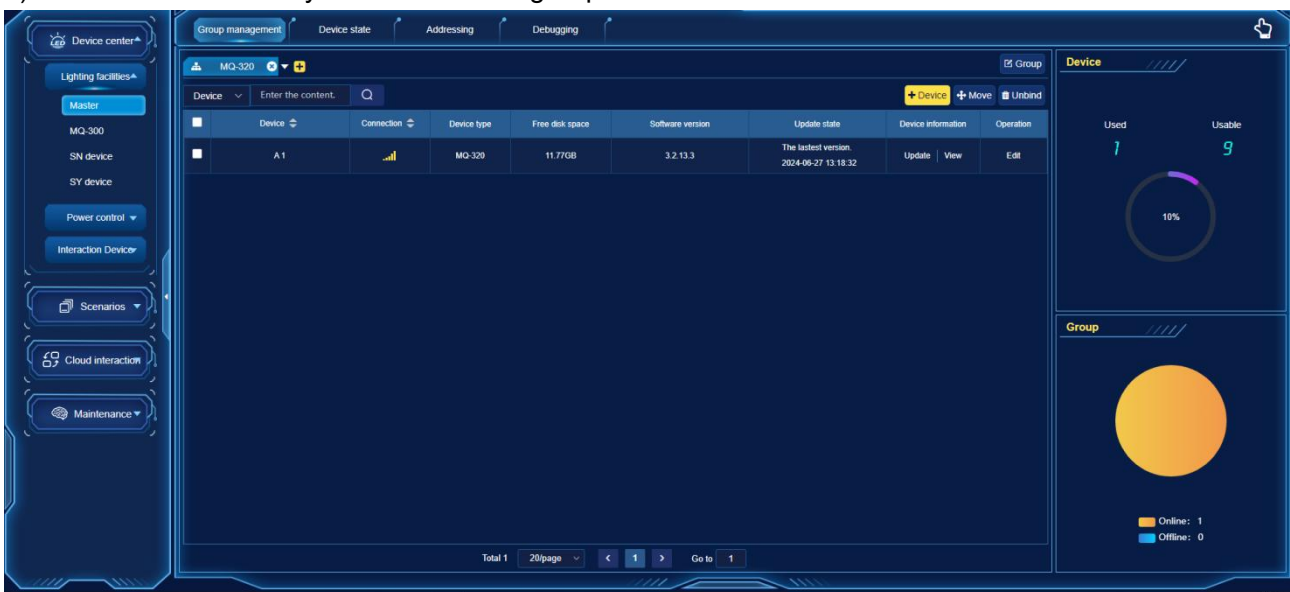

### 11.3.1.2. SET THE STATE BY CLOUD SERVER ON WEBSITE

Under the interface of "Device center" - "Lighting facilities" - "Master" - "Device state", We can view device status information, such as connection, playback, and brightness.

After the device is selected, the right property bar can set the unified playback speed and brightness / Gamma of all programs on the device.

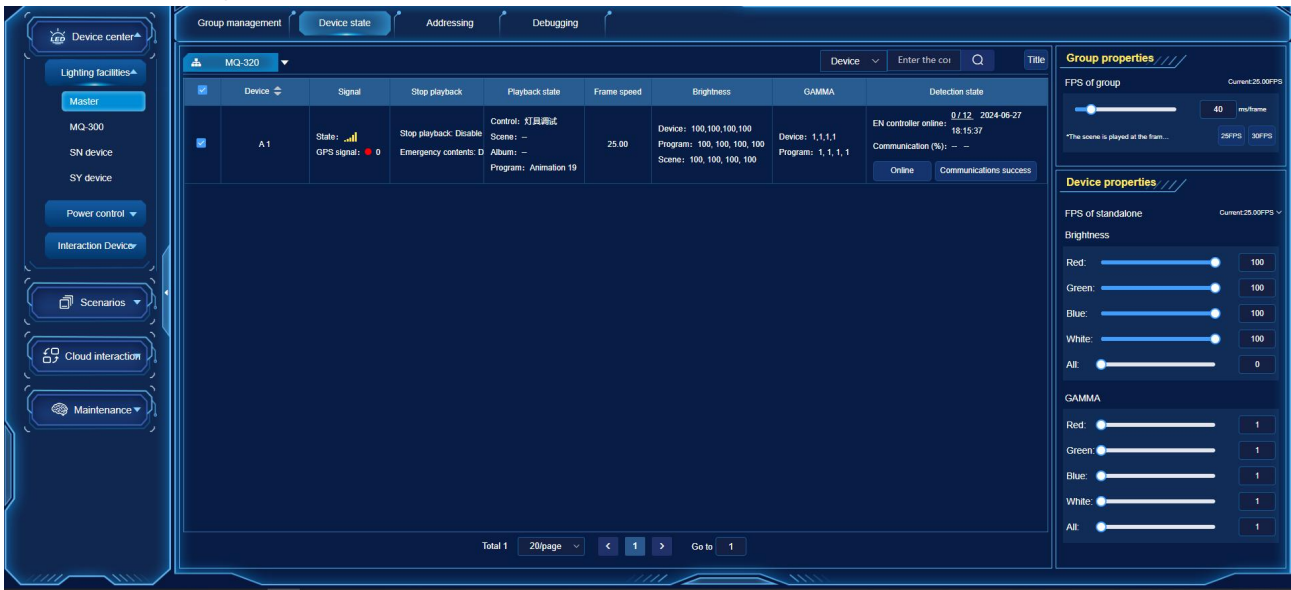

### 11.3.1.3. ADDRESSING AND DEBUGGING

Under the interface of "Device center" - "Lighting facilities" - "Master" - "Addressing",

After the node device is  enabled and the controller "Online" is selected, the address parameters of the luminaire can be set for writing.

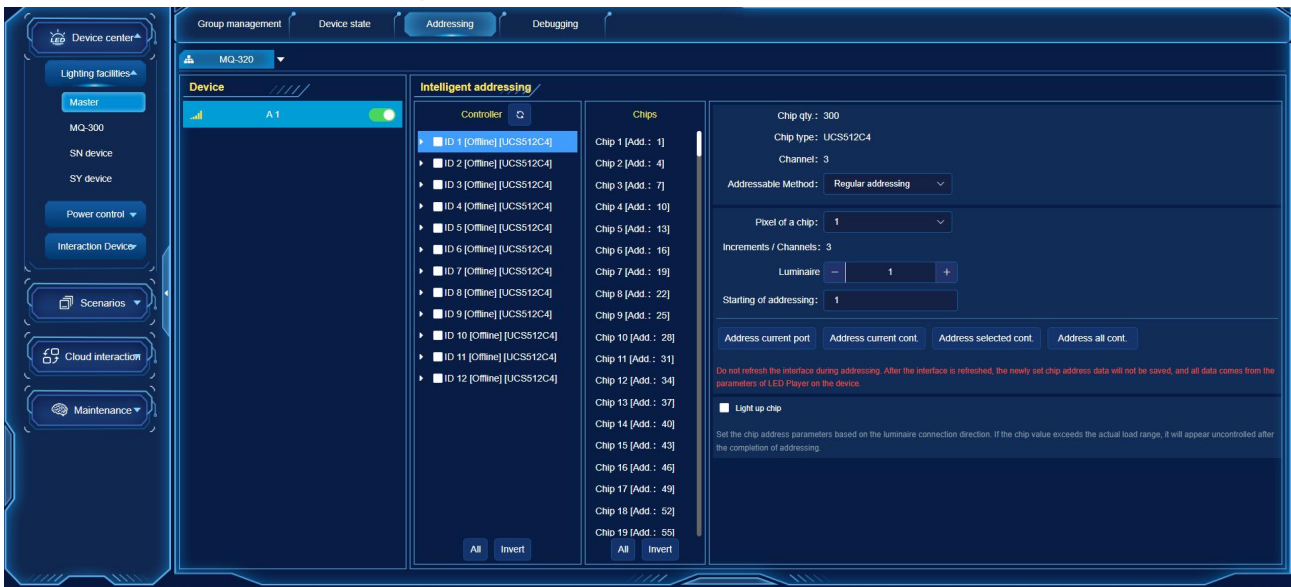

Under the interface of "Device center" - "Lighting facilities" - "Master" - "Debugging",

Enable the node device and select the Online controller to set parameters for debugging and verification.

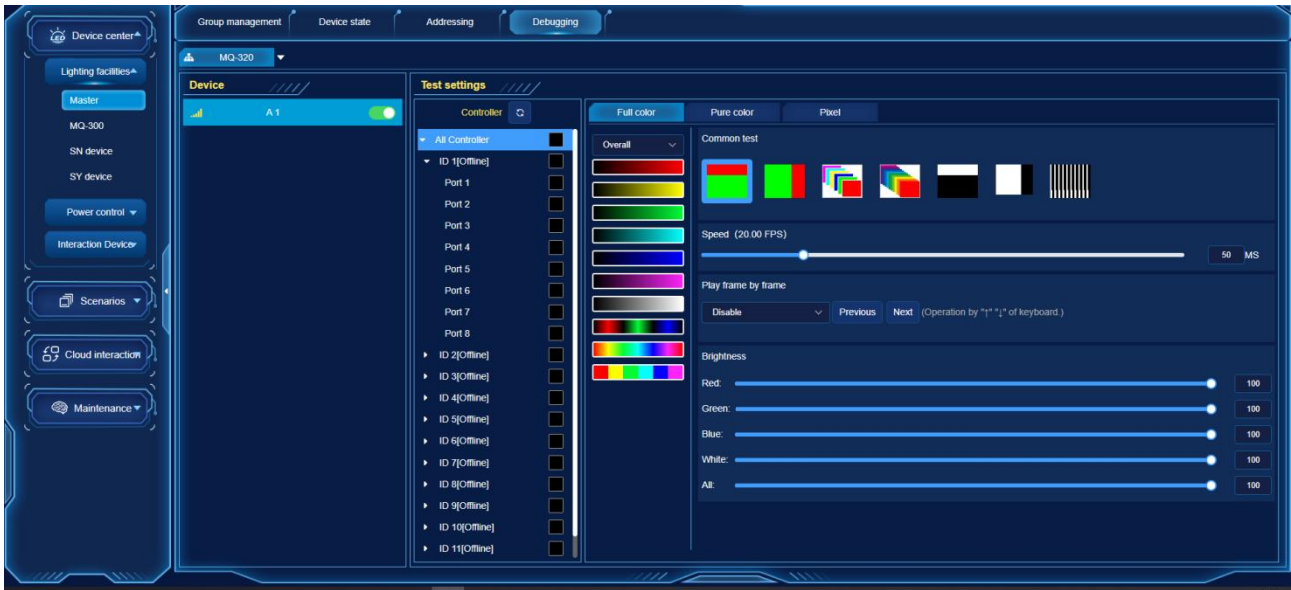

\* Note,

1. Unable to write the luminaire address for the offline device.
2. If no network adapter is selected on the local device, the luminaire cannot be addressed. Select the corresponding network adapter on the device first.
3. It does not save data! Do not switch or refresh the page while writing.
4. It cannot be control if the chip address exceeds the actual wiring address range of the project.
5. When leaving the luminaire addressing interface, the luminaire will play normally.

## 11.3.2. MATERIAL MANAGEMENT

### 11.3.2.1. UPLOAD AND MANAGE ANIMATION MATERIALS

Under the interface of "Scenarios" - "Program editor" - "Master" - "Material libraries",

After selecting the corresponding material library, click [Upload \*\*\*] and upload the animation according to the prompts. After uploading, we can click "Edit" under the operation of the material to modify the name and label twice. Storage and statistics information is displayed on the right of the page.



### 11.3.2.2. AUDITING THE MATERIALS

Under the interface of "Scenarios" - "Program editor" - "Master" - "Auditing",  
After selecting the material that we want to review, click "Fail" or "Pass".

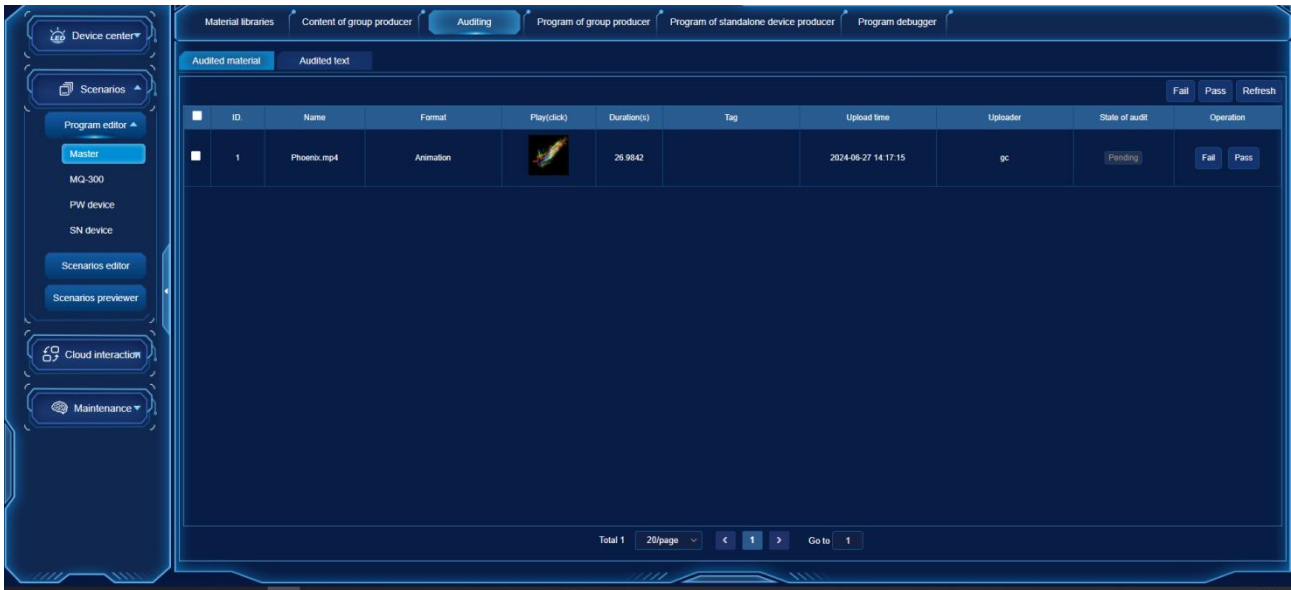



### 11.3.3. PORGRAM DESIGNING

#### 11.3.3.1. PRODUCE PROGRAM OF GROUP

Under the interface of "Scenarios" - "Program editor" - "Master" - "Program of group producer",

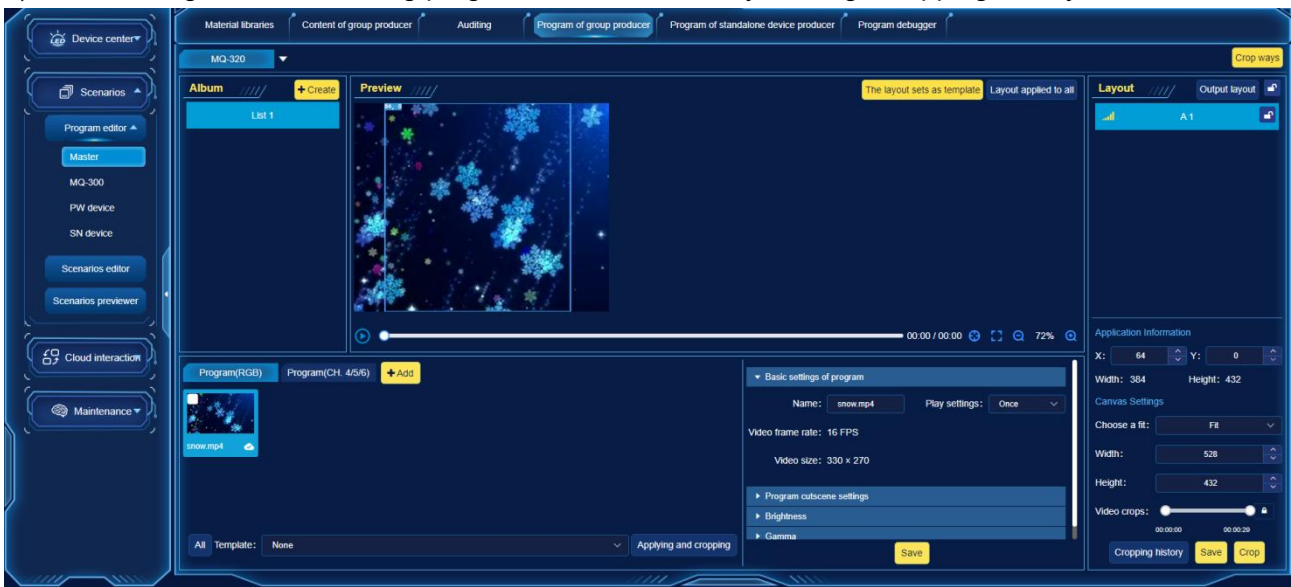
- 1) Click "+ Create" to add playlists and programs as instructed.
- 2) Click "+ Add" to add programs as instructed. (The program setting of channel 4/5/6 is similar.)
- 3) After selecting a single program, we can modify "Basic Settings", "Cut-scene Settings", "Brightness" and "Gamma", and click "Save" after modification.
- 4) If we need to readjust the parameters of the material such as position, we need to click "Crop" twice to cut.
- 5) The cutting and downloading progress can be viewed by clicking "Cropping history".





Description: After the material is downloaded, it is displayed  in the lower right corner of the card.

### 11.3.3.2. PRODUCE PROGRAM OF STANDALONE DEVICE

Under the interface of "Scenarios" - "Program editor" - "Master" - "Program of standalone device producer",

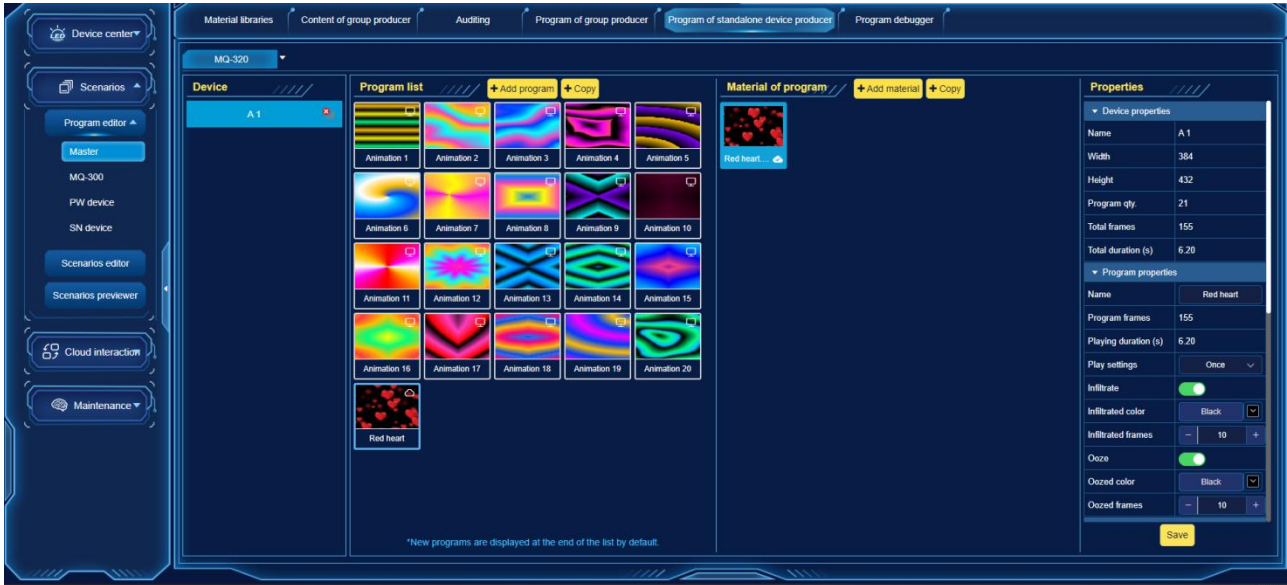

- 1) Click "+Add program" to add programs as instructed. (Click "+Add material" for similar operations.)
- 2) After selecting a single program material, you can modify the node properties, and click "Save" after modification.



Description: After the material is downloaded, it is displayed  in the lower right corner of the card. If the material is reused, it can be quickly invoked without a second download by "+Copy". The display icon in the top right corner of the show indicates the location created for the show.

### 11.3.3.3. DEBUGGING ANIMATION

Under the interface of "Scenarios" - "Program editor" - "Master" - "Program debugger", switch the control mode to "Debugging  Scene". We can play the program in real time, and the actual animation needs to be based on the color presented by the luminaires.

The platform supports the debugging preview of the device's co-controlled programs and stand-alone programs. If we need to debug stand-alone programs, click " Group" to the right of the device under "The program of Standalone device" to change to " Standalone".

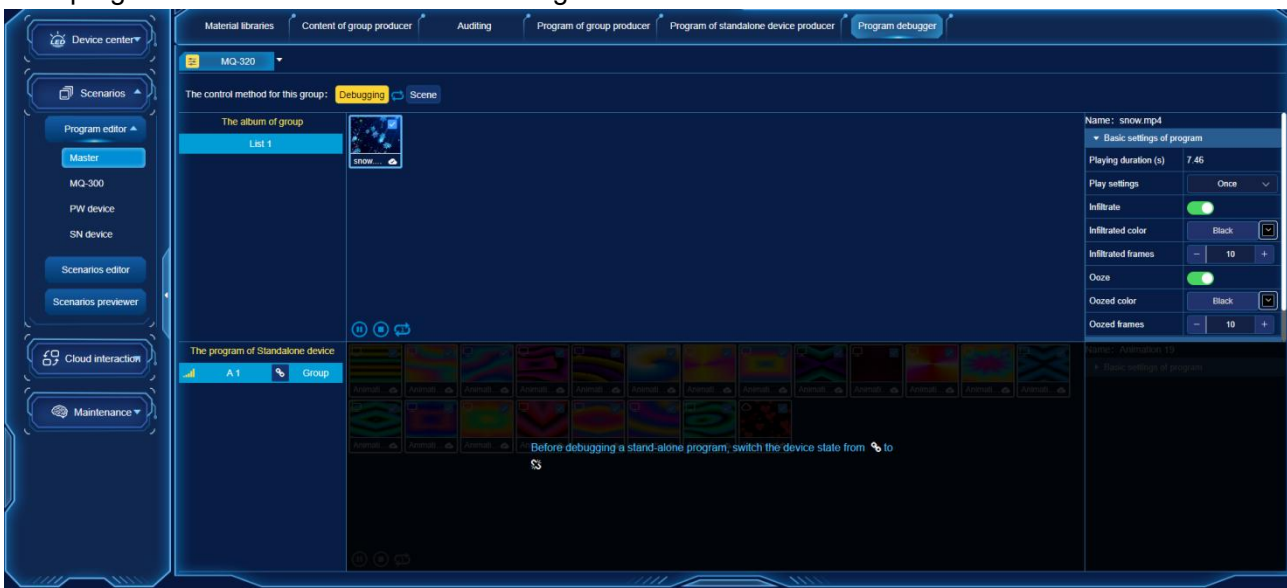



### 11.3.4. SCENARIO

#### 11.3.4.1. ADD SCENE PROGRAM (SCENE CHOREOGRAPHY)

Click “+New” to create the date, time, and animation program to be played as prompted (support for Group programs and Stand-alone programs).

 (yellow scale bar) is group program, and  (orange scale bar) is stand-alone program.

The scene card must be in  to be valid. If it is in , it will be disabled, and the date and day match will not play the program animation.

A date segment is a scene, and only one scene mode can be played at the same time. The playback priority is related to the sequence. **If the date of a scenario mode overlaps, execute the scenario mode with a higher priority.** (In the figure below, the order of the programs is prefaced.)

There are repeated time periods between programs, and the playback priority is: stand-alone program > group program.

In the original scene, we can click “+Add program” after selecting the scene card to add it twice. Similarly, click the scene program time bar, we can also add, delete or sort the program twice.

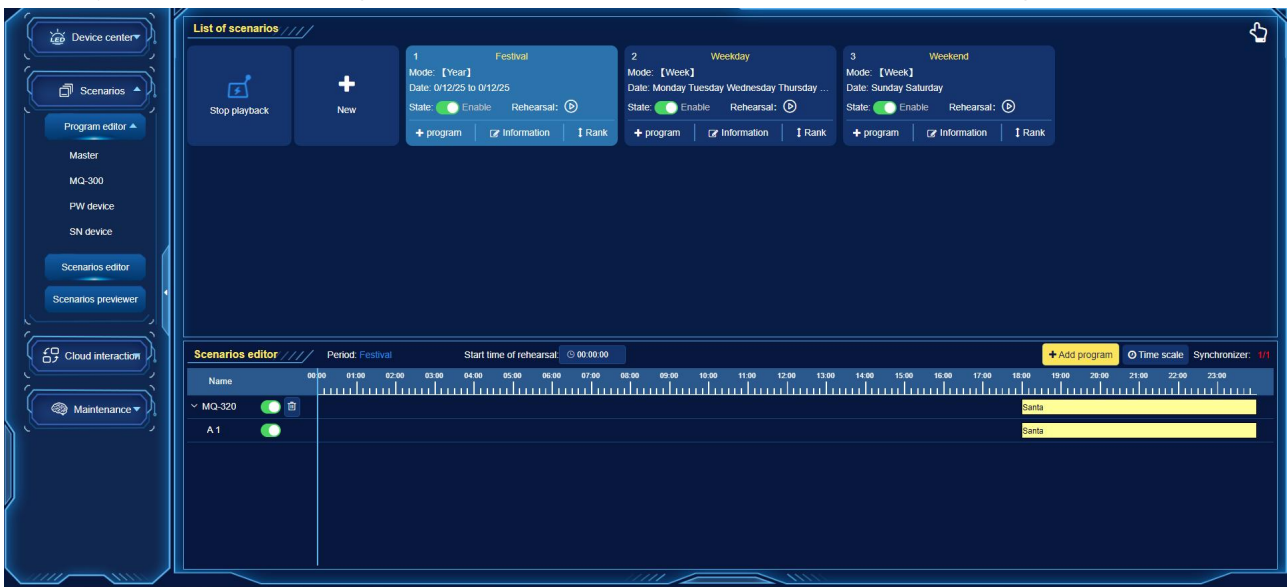

### 11.3.4.2. SCENARIOS PREVIEWER

Scenarios previewer only supports preview, rehearsal scenes and stop playback.



## 11.4. OPERATION BY CLOUD SERVER OF PHONE

### 11.4.1.1. SETING DEVICE AND DEBUGGING ANIMATION ON PHONE

In the "Device list", select "Device" under the corresponding "Group" to set speed, brightness, and Gamma.

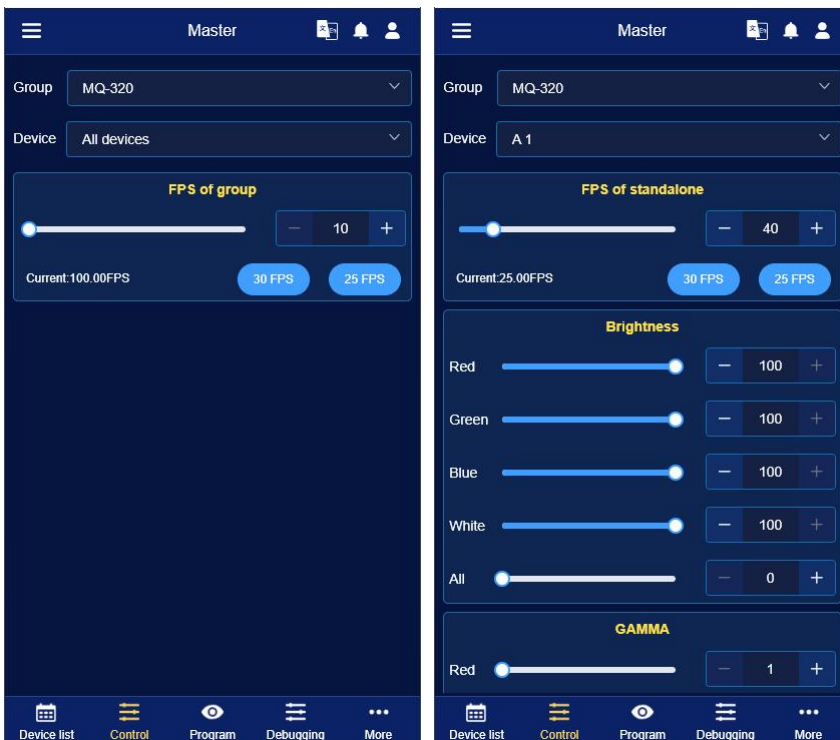

Under "Program", switch the playback mode to "Debugging" and select the device under the corresponding "Group" to play the program immediately. The actual lighting effect needs to be based on the color presented by the luminaires.

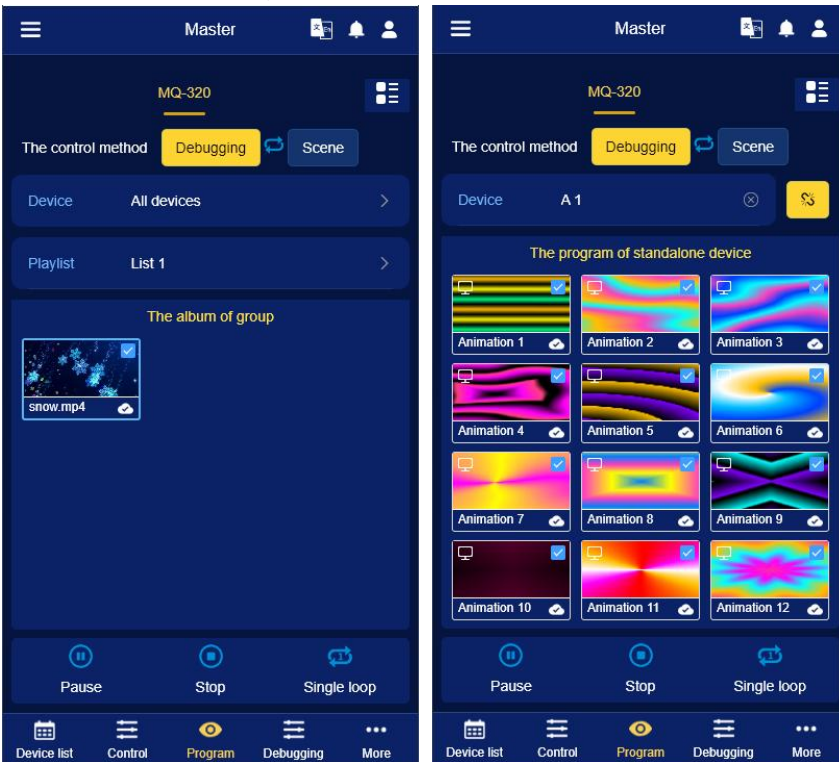

#### 11.4.1.2. ADDRESSING AND HARDWARE DEBUGGING ON PHONE

Under "Debugging", select "Device" and select addressing or debugging to enter the luminaire writing operation interface or luminaire debugging interface.

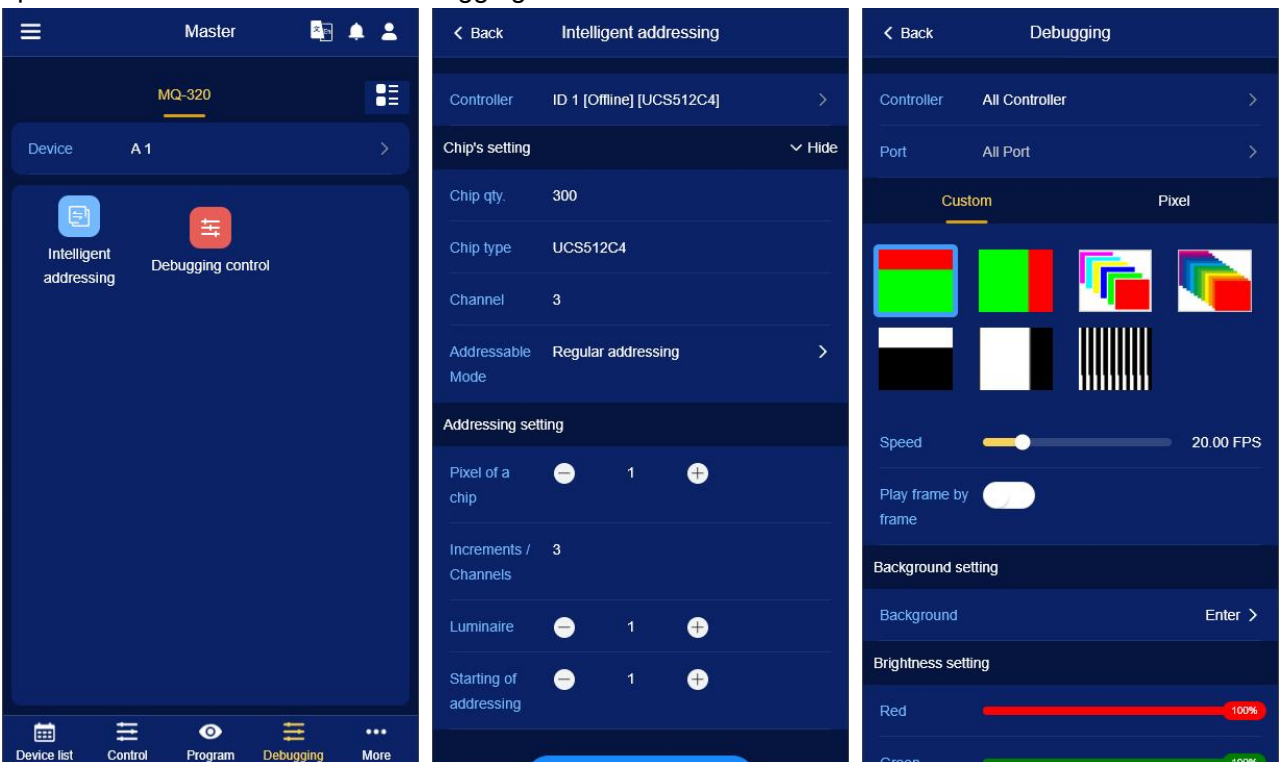

### 11.4.1.3. MORE (AUGITING AND CHART)

We can call up "Material Audit" and "Chart" in "More" to review the material and view the equipment status of the project.

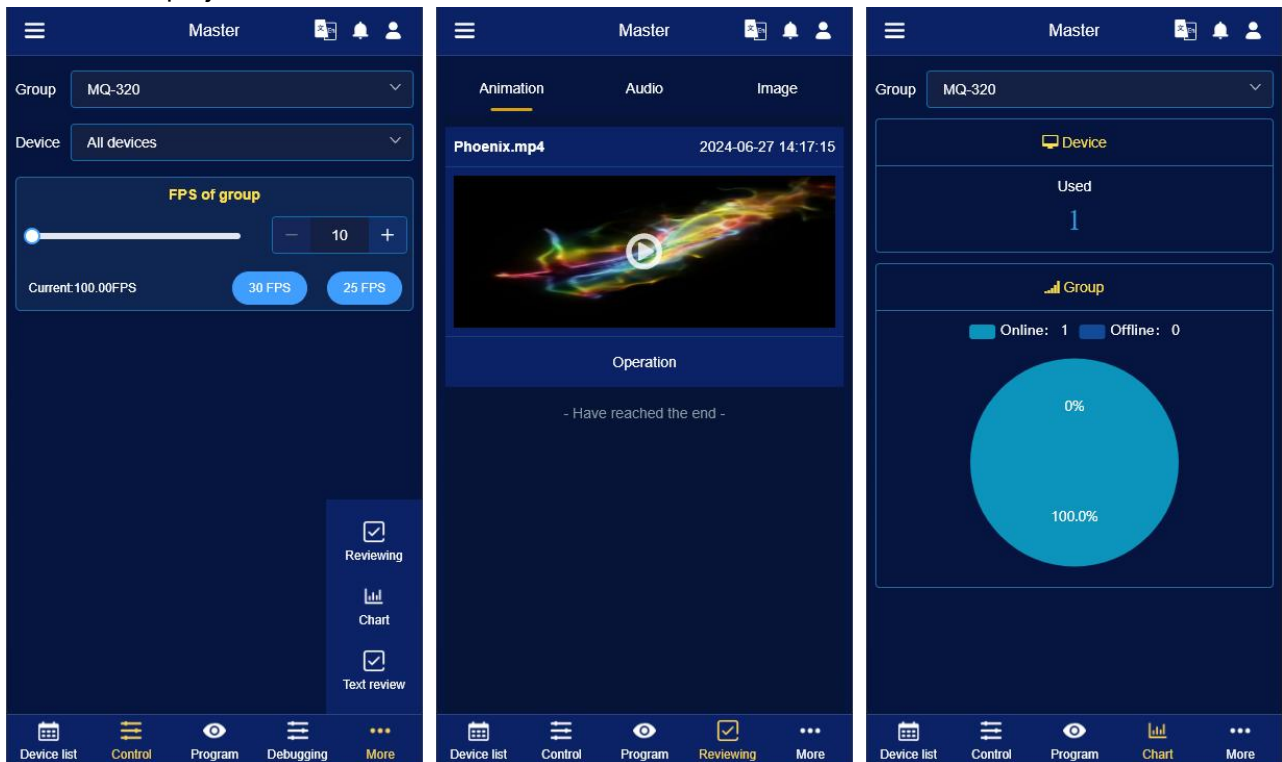

### 11.4.1.4. SCENE CONTROL

Select the upper left corner of the mobile phone mini program interface, and select "Scenarios Previewer" under the pop-up window to open the scene interface. We can view the scene, rehearsal scene and stop play.

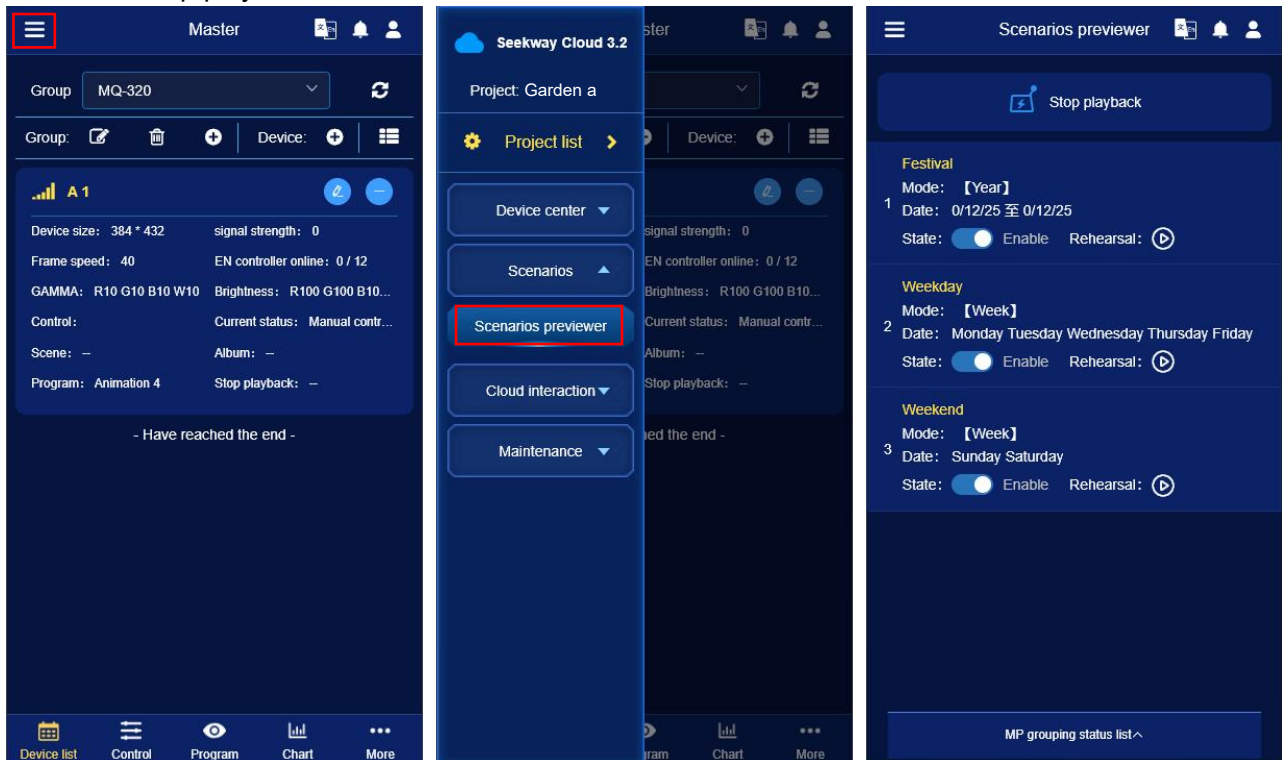

## 12. LOADING SPECIFICATION

Speed (fps)	Project size (W * H)	Project type	Actual count	
			3 channels	4 channels
30	200*1000	Full load	200 thousands	150 thousands
20	300*1000	Full load	300 thousands	About 220 thousands
30	617*410	Full load	About 60 thousands	About 40 thousands
26	1991*1000	Full load	200 thousands	150 thousands
21	4001*1219	Full load	About 180 thousands	About 130 thousands

Calculation base, full load project 200 thousands: 30fps (33.33ms). It is the fastest speed.

For each additional insertion of 1 times zero (blank gap), the transmission time increases by 0.5 milliseconds. For each additional 10 thousands, it adds 1.5 milliseconds.

**Note:** The table is for reference only, The speed will vary according to the chip, transmission baud rate, load per path and the number of sub-controls.

## 13. OTHER CONSIDERATIONS

- 1, each turn on / off interval of more than 30s.
2. Music files are not supported.