



A308 MANUAL

Version: 2.0.2

Model: A308-D1

2024-11

CONTECT

1. FUNCTION OVERVIEW	1
2. TECHNICAL PARAMETERS	1
2.1. PRODUCT INFORMATION	1
2.2. COMPONENT	2
2.3. INDICATOR DESCRIPTION	2
2.4. CONNECTION MODE	3
2.4.1. PORT INTRODUCTION	3
2.4.2. TRANSMISSION DISTANCE	3
2.4.3. OPTICAL FIBER COMMUNICATION	4
3. APPLICATION SOLUTION	4
3.1. A SINGLE DEVICE WORKS ALONE	4
3.2. MULTIPLE DEVICES IN A GROUP WORK SYNCHRONOUSLY	4
3.3. MULTIPLE DEVICES IN MULTIPLE GROUPS WORK SYNCHRONOUSLY	5
3.4. DMX CONNECTION	6
4. BASIC OPERATION	7
4.1. BUTTON	7
4.2. INTERFACE INTRODUCTION	7
4.3. SPEED SELECTION	7
4.4. MENU SETTINGS	8
4.5. ARTNET SETTINGS	10
4.6. SETTING THE ID AND GROUP OF CONTROLLER	11
4.6.1. SETTING ID ON CONTROLLER	11
4.6.2. SETTING ID, GROUP AND RANK ON CONTROLLER	11
4.6.3. ONLINE SETTING BY MAGIC PLAYER	12
5. DMX512 CONTROL SETTINGS	12
6. ADDRESSABLE OPERATION	13
6.1. CHIP SUPPORTED	13
6.2. SUCCESSFULLY ADDRESSED AND SET PARAMETERS	14
6.3. ONLINE ADDRESSING BY MAGIC PLAYER	15
6.4. ADDRESSING ON CONTROLLER BY SD CARD FILE	17
6.5. ADDRESSING CHECK	17
6.5.1. CHECK THE ADDRESSING ON CONTROLLER	17
6.5.2. CHECK THE ADDRESSING BY PLAYER	18
7. IP SETTING ON PC	18
8. ART-NET SETTINGS ON SOFTWARE	19
8.1. OBTAINING CONTROLLER INFORMATION	19
8.2. SET BASIC PARAMETERS OF THE CONTROLLER	19
8.3. SELF-CHECKING FUNCTION	20
9. OPERATIONS RELATED TO SD CARD FILES	21
9.1. GENERATE THE SD CARD FILE	21
9.2. UPDATES THE SD CARD ONLINE THROUGH NETWORK CABLE	22
9.3. COPY BY LED PLAYER	22
9.4. SD CARD COPY	23
10. ERROR CODE AND TROUBLE SHOOTING	23
11. FITTINGS	24

1. FUNCTION OVERVIEW

1. Support online control and offline control automatic switching mechanism.
 - 1) When the Art-Net protocol software is online to control the luminaires, the single output outlet of the controller can output the data of the control of 6 universes (3072 channels) at most.
 - 2) When the Magic Player (Seekway protocol) is online output control luminaires, addressing, debugging, configuration, a single output outlet of the controller can output control up to 3840 channels.
 - 3) When a single controller plays SD card effect files, the controller can output a maximum of 3840 control channels in one port.
2. Supports offline synchronization through Ethernet and can play independently by group.
3. Supports 100 level brightness settings (single channel or overall). And support for setting overall Gamma correction/grayscale smoothing.
4. Support access to DMX console control.
5. Can set the automatic extension ID of all controllers in a single cascaded mode with one click.
6. Supports online firmware update and effect file transfer over Ethernet, eliminating repeated insertion and removal of SD card files.

2. TECHNICAL PARAMETERS

2. 1. PRODUCT INFORMATION

Cover material: Iron

Input voltage: AC 100V - 240V

Pixel driven: Art-Net protocol: 512 channels *6 universes *8 port / each controller

Seekway protocol: 3840 channels *8 port / each controller. 400 controllers can be connected in series and parallel using switches.

Cascade signal: Strand Ethernet protocol

Output port: TTL & RS-485 * 8 ports

Working power: <10W

Working temperature: -10°C~55°C

Relative humidity: ≤ 50% RH

Transmission distance: Use UTP—unshielded twisted pair cable, distance between the controllers can be 100m.

Please add signal amplifier if the distance of SN cascade is over 100m.

For further distance of SW Ethernet Protocol, optical fiber converter can be used and the distance can reach 5 km.

IP grade: IP20 (Prevent people from touching the components inside electrical appliance, prevent object which diameter is more than 12.5mm from getting in, no special protection to water or moisture.)

- Working environment:
1. Only indoor light screens can be controlled.
 2. Please do not install the controller in magnetic, high pressure, high temperature or seriously wet environment.
 3. Please do connect the earth safely in order to reduce risks of fire and damage which cause by short circuit.

4. Please ensure AC100-240V power supply is used, and same polarity is connected between transformer and controller in order to guarantee the proper supply voltage.
5. No waterproof function in the control system, please pay attention on rainproof and waterproof during installing.

Net weight: 0.976 kg
 Size: L253*W137*H45
 (Unit mm)

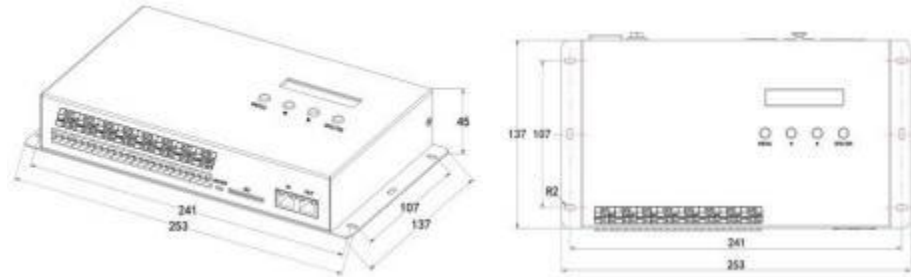

2. 2. COMPONENT

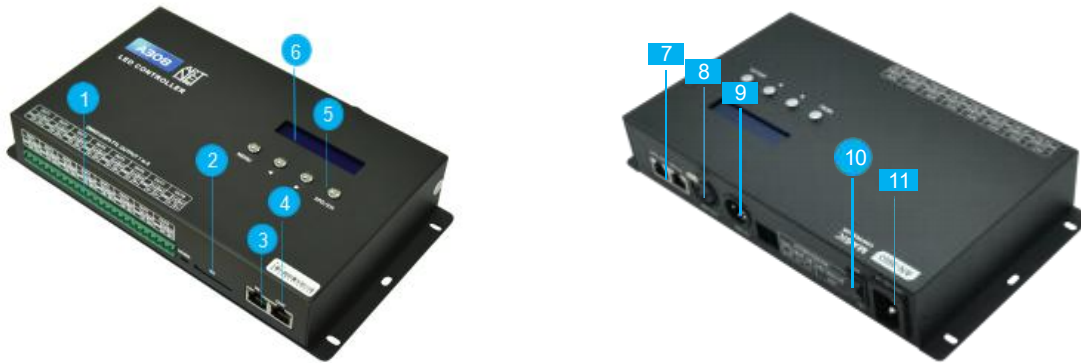

- | | | |
|-----------------------------------|-----------------------------|-----------------------------|
| ① Output control lighting fixture | ② SD card slot | ③ Uplink port (RJ45) |
| ④ Downlink port (RJ45) | ⑤ Button | ⑥ LCD screen |
| ⑦ DMX control port (RJ45) | ⑧ DMX control port (Cannon) | ⑨ DMX control port (Cannon) |
| ⑩ Power switch | ⑪ Power input AC100-240V | |

2. 3. INDICATOR DESCRIPTION

Indicator	Description
Uplink port	Top left light (signal indicator): flicker when the 8 output port output the correct signal.
Downlink port	Top left light (receive data indicator): flicker when the control gain the data completely.

2. 4. CONNECTION MODE

2. 4. 1. PORT INTRODUCTION

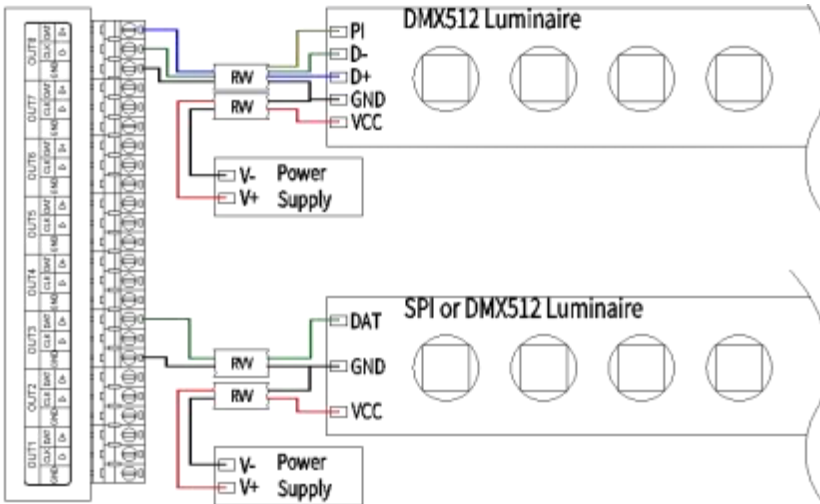

★ Signal cables connection cautions:

1. Use UTP—Unshielded Twisted Pair (resistance per 100M<10Ω), low quality Ethernet cables, telephone cables and copper wires are unavailable.
2. Use one group twisted pair, suggest green + green white or orange + orange white. The quality and color of the cable are very important. Blue and brown wires greatly influence the signal transmission. Please don't use several groups of twisted pairs together.
3. Controller signal output GND must connect directly with input GND of lighting fixture. Cannot connect with lighting fixture through power supply.
4. Switch on the controller after all hardware signal and power cables are connected. Please don't CONNECT / DISCONNECT the signal cables while the controller is power on; avoid back-flow current burning circuit and components of output port.

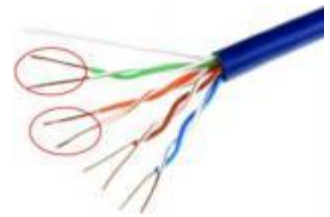

2. 4. 2. TRANSMISSION DISTANCE

Transmission Type	Signals	Medium	Distance (M)	Remark
PC → Controller	100M	UTP CAT5e	50-80	
Controller → Controller	Ethernet			
Controller → DMX lighting	RS-485	UTP CAT5e	30-50	The address wire must be within 5m.
DMX lighting → DMX lighting		Three core wire	1-20	
		Four core wire	1-20	
Controller → SPI lighting	TTL	UTP CAT5e	5-20	Controllable pixels reduce if wire is over 5m.
DMX lighting → DMX lighting		Two core wire	1-5	
		Three core wire	1-5	
SPI lighting → SPI lighting	TTL	UTP CAT5e	1-2	Pixels controlled less if over 1m.
		Two core wire	0.1-1	

2.4.3. OPTICAL FIBER COMMUNICATION

Must use single mode transceivers. User can use single fiber or double fiber (alternative) according to on-site condition. The double fiber transceiver must be connected with two optical fibers.

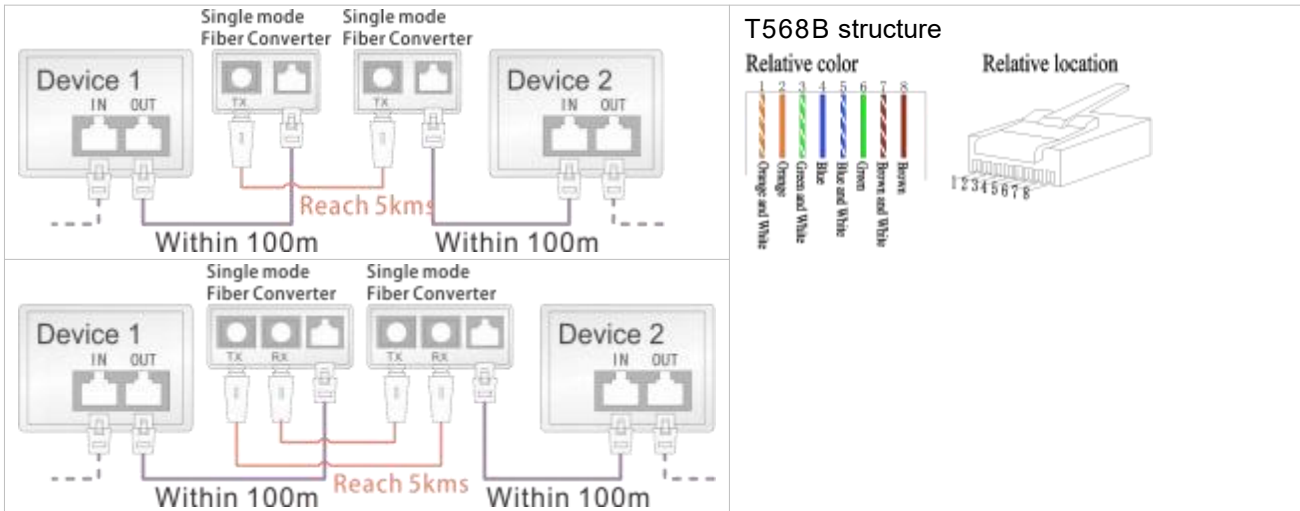

Use UTP, distance between the controllers can be 100m. It can be 5km if use the optical fiber.

3. APPLICATION SOLUTION

3.1. A SINGLE DEVICE WORKS ALONE

When the upper limit of the loaded liminaires' channels does not exceed 30720 channels, the project can be satisfied with only one controller. At the same time, we can also choose to access the computer to receive the Player signal to achieve the software on the same screen.

Note: When receiving Player signal, the SD card effect of the controller as a standby machine mode, only when there is no Player signal, SD card will start to work.

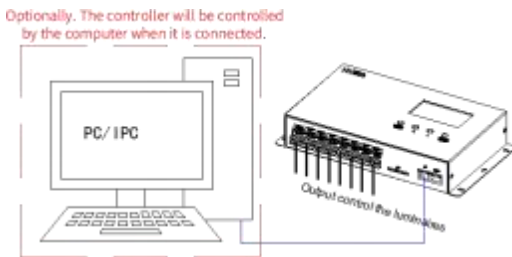

3.2. MULTIPLE DEVICES IN A GROUP WORK SYNCHRONOUSLY

When the upper limit of the loaded lighting channel exceeds 30720 channels, the project needs to [connect multiple controllers and set the master/slave scheme](#) for cascaded synchronous control. Its characteristics are as follows.

1. When the controller is connected to the computer, it can directly receive and play animation and debugging functions of the software. It can also switch to play animation files in the software or SD card according to the network communication status with the computer.
2. In the whole control scheme, any controller can be set as the host. [However, there is only one host in a group.](#) If multiple hosts are displayed, the controller displays an E37 message.
3. 400 controllers can be connected to each other in series using a switch. A maximum of 50 devices can be connected to a single link.

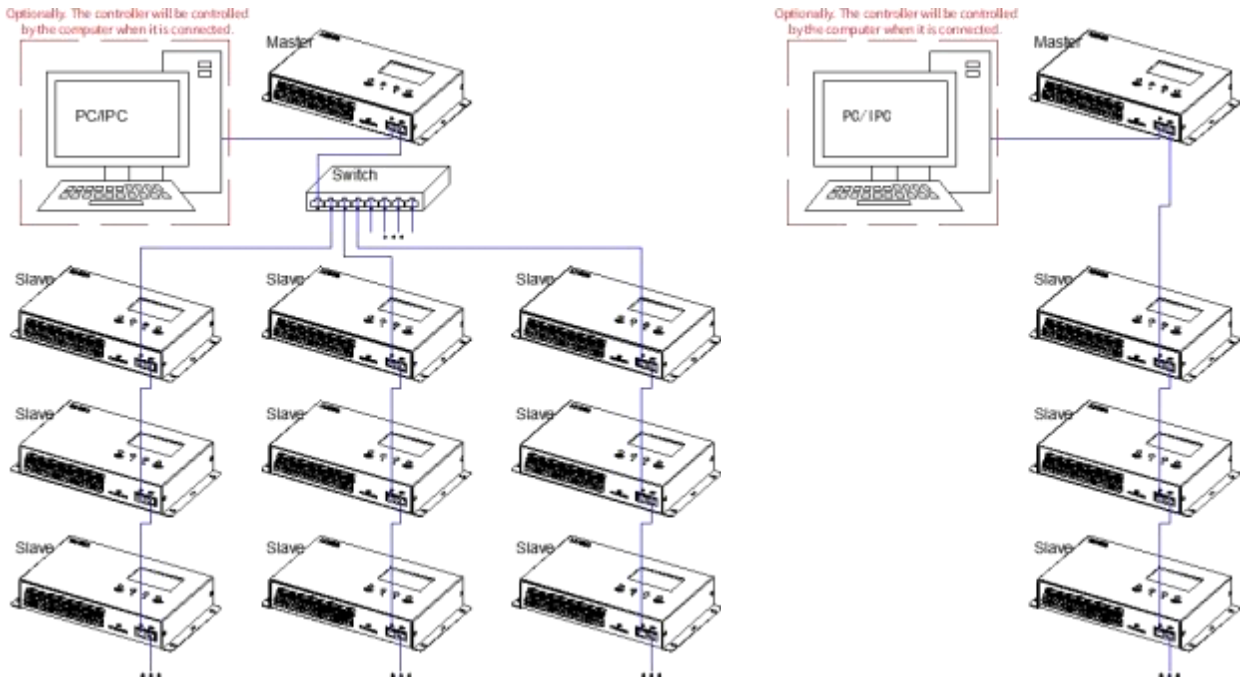

3. 3. MULTIPLE DEVICES IN MULTIPLE GROUPS WORK SYNCHRONOUSLY

When the upper limit of the loaded lighting channel exceeds 30720 channels, the project needs to [connect multiple controllers and set the master/slave scheme](#) for cascaded synchronous control.

In order to facilitate project group management, the controllers can be set to be classified into groups to realize the synchronous control mode of more groups.

Its characteristics are as follows.

1. When the controller is connected to the computer, it can directly receive and play animation and debugging functions of the software. It can also switch to play animation files in the software or SD card according to the network communication status with the computer.
2. In the whole control scheme, any controller can be set as the host. [However, there is only one host in a group.](#) If multiple hosts are displayed, the controller displays an E37 message.
3. 400 controllers can be connected to each other in series using a switch. A maximum of 50 devices can be connected to a single link.
4. If it is out of be controlled by the player, the controller under each group can only achieve time synchronization playback among the devices in the same group.
5. If we need to assign controller ids and groups under project that has multiple groups, remove controllers in other groups from the current link first to avoid consolidating all controllers into the same group.

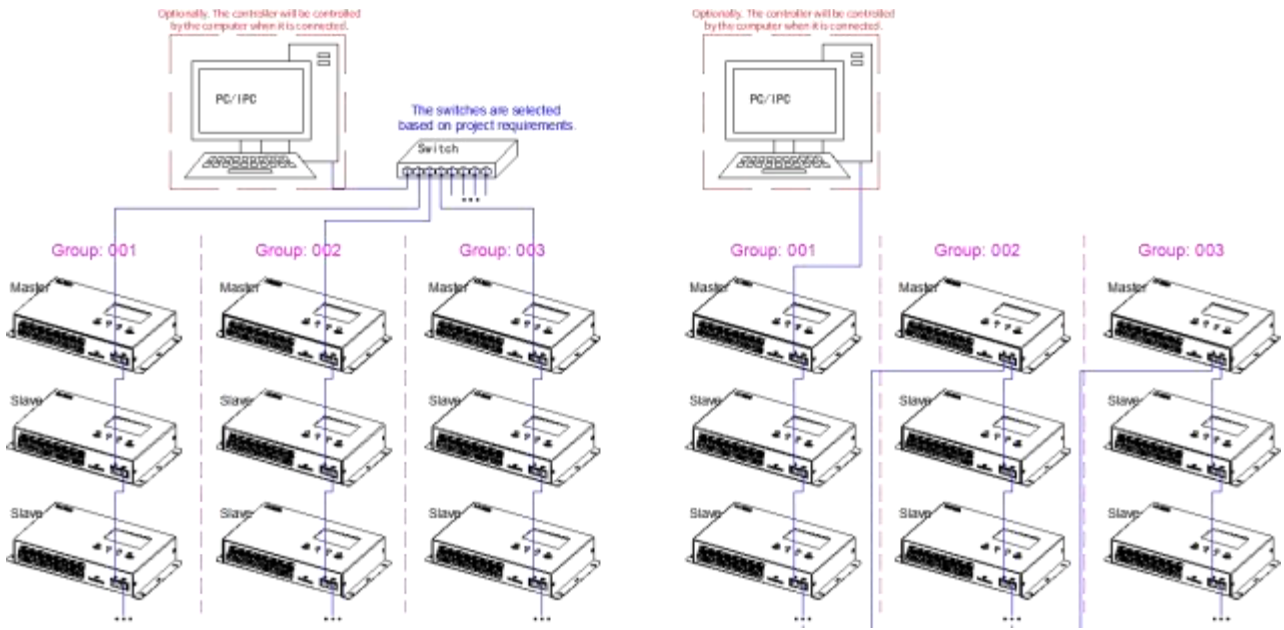

3. 4. DMX CONNECTION

The controller can be controlled by the DMX512 console to change the animation, speed and so on. Network ports connected to multiple controllers in parallel. (Each controller has the same or different address.)

Cannon ports connected to multiple controllers in parallel. (Each controller has the same or different address.)

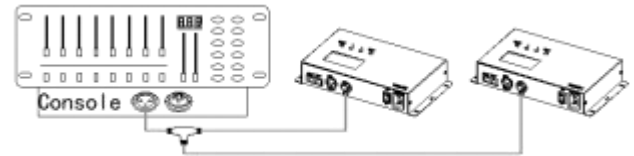
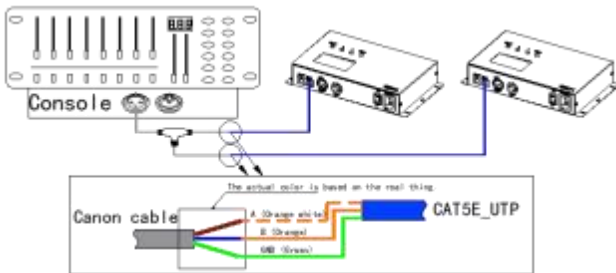

The subordinate controllers are cascaded from the primary and secondary controllers. (Only need to set the host address, and all slave machines are connected to the host.)

Serial access controller cannon port. (Each controller has the same or different address.)

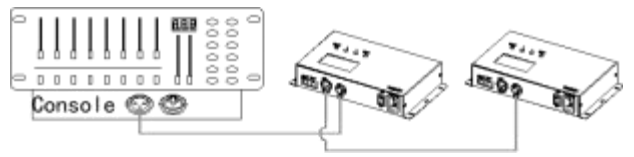
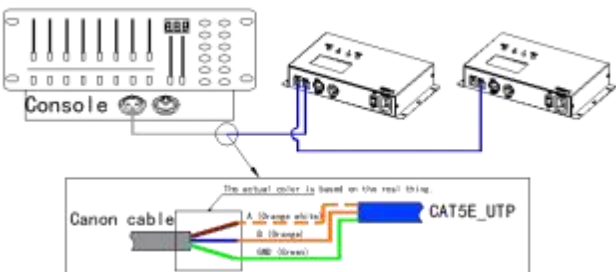

T568B structure

8	Brown	Signal GND
7	Brown white	Signal GND
6	Green	Signal GND
5	Blue white	None
4	Blue	None
3	Green white	None
2	Orange	Signal D-/B
1	Orange white	Signal D+/A

❖ [The pin position of The XLR is for reference only, and the final signal shall be subject to the actual XLR and DMX512](#)

[controller.](#)

4. BASIC OPERATION

4. 1. BUTTON

Button	Operation	Description
MENU	Press	Return.
	Long press	Enter/exit the "parameter settings" interface.
◀	Press	Decrease, suitable for changing effect and setting parameters.
	Long press	Quickly decrease the value of the effect/parameter.
▶	Press	Increase, suitable for changing effect and setting parameters.
	Long press	Quickly increase the value of the effect/parameter.
SPD/EN	Press	Set the effect speed and choose the parameter Settings.
	Long press	Save the parameter Settings

4. 2. INTERFACE INTRODUCTION

➤ Working online,

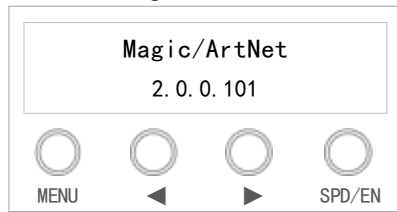

➤ Working offline,

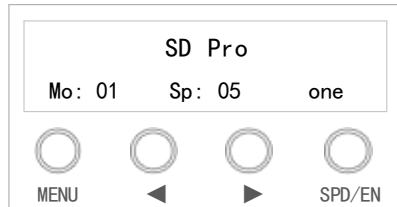

Display	Introduction
Working online	It's online state when it is controlled by Player on PC.
2.0.0.101	The controller's IP.
SD Pro	It's offline state when it is working with SD card or out off PC controlling.
Mo (Mode)	The playback animation ID.
Sp (Speed)	The playback speed.
One (Loop)	The loop state, selection for one (single loop), full loop, random.

The selection of unsupported functions will not display on interface.

4. 3. SPEED SELECTION

Press button "SPD/EN" on control panel to select play speed. The less the rate, the quicker the speed.

Parameters	Speed																		
Interface	01	02	03	04	05	06	07	08	09	10	11	12	15	20	30	50	80	99	
Speed (ms)	10	20	30	40	50	60	70	80	90	100	110	120	150	200	300	500	1000	2000	
FPS	100	50	33	25	20	17	14	13	11	10	9	8	7	5	3	2	1	0.5	

4. 4. MENU SETTINGS

Long press “MENU” enter/exit MENU SETTING.

Press “◀” and “▶” to select function. Press “SPD/EN” to confirm.

▶ Test Lights	1/7
Set ID & Group	
▶ Brightness	4/7
Set Gamma	
▶ About	7/7

▶ Set Art-Net	2/7
Set All ID	
▶ Port Level	5/7
Addressing	

▶ DMX Control	3/7
SYNC Setting	
▶ Reset	6/7
Run Info	

First Menu	Second Menu	Introduction														
Test Lights (Debug)	<table border="1"> <tr> <td>IC: ***</td> <td>1/3</td> </tr> <tr> <td>Speed : ***</td> <td>2/3</td> </tr> <tr> <td>Chn : ***</td> <td>Bri : ***</td> </tr> <tr> <td>Lot : ***</td> <td>3/3</td> </tr> <tr> <td>M : ***</td> <td></td> </tr> </table>	IC: ***	1/3	Speed : ***	2/3	Chn : ***	Bri : ***	Lot : ***	3/3	M : ***		<p>Enter to debug. Parameter below, IC, is the chip type in luminaire.</p> <p>Speed, is the speed in debugging.</p> <p>Chn, is the channel number of luminaire.</p> <p>Bri, is the brightness in debugging.</p> <p>Lot, is only for Manual Point and Manual Heap up. Manual Point, is lighting up the Nth pixel.</p> <p>Manual Heap up, is lighting up the first to the Nth pixels.</p> <p>M, is the debug of mode. Selection for CH1, CH2, All CH, Color Change, Color Grad, Manual Point, Manual Heap up, Auto Point, Auto Heapup, Channel Change.</p>				
IC: ***	1/3															
Speed : ***	2/3															
Chn : ***	Bri : ***															
Lot : ***	3/3															
M : ***																
Set ID & Group	<table border="1"> <tr> <td>Group : **</td> <td></td> </tr> <tr> <td>ID : **</td> <td></td> </tr> </table>	Group : **		ID : **		Set the ID and group of the controller.										
Group : **																
ID : **																
Set Art-Net	<table border="1"> <tr> <td>Start U : ***</td> <td>1/4</td> </tr> <tr> <td>Port Us: ***</td> <td></td> </tr> <tr> <td>Channel : ***</td> <td>2/4</td> </tr> <tr> <td>IC: ***</td> <td></td> </tr> <tr> <td>Chn Seq. : ***</td> <td>3/4</td> </tr> <tr> <td>Baud: ***</td> <td></td> </tr> <tr> <td>IP: ***.***.***.***</td> <td>4/4</td> </tr> </table>	Start U : ***	1/4	Port Us: ***		Channel : ***	2/4	IC: ***		Chn Seq. : ***	3/4	Baud: ***		IP: ***.***.***.***	4/4	<p>Art-net parameters are set so that the controller can be controlled by the art-net protocol software. See 4.5. ARTNET SETTINGS for details.</p> <p>Start U, is start universes.</p> <p>Port Us, is number of universes.</p> <p>Channel, is the channel value of a pixel.</p> <p>IC, is the chip in luminaire.</p> <p>Chn Seq., is channel sequence.</p> <p>Baud, is the baud of output.</p>
Start U : ***	1/4															
Port Us: ***																
Channel : ***	2/4															
IC: ***																
Chn Seq. : ***	3/4															
Baud: ***																
IP: ***.***.***.***	4/4															
Set All ID	<table border="1"> <tr> <td>▶ Set ID</td> <td></td> </tr> <tr> <td>Set ID & Group</td> <td></td> </tr> </table>	▶ Set ID		Set ID & Group		<p>Quickly set the IDs, groups, and control hierarchy of all controllers on the same link. See 4.6.</p> <p>SETTING THE ID AND GROUP OF CONTROLLER for details.</p>										
▶ Set ID																
Set ID & Group																
DMX Control	<table border="1"> <tr> <td>Dmx Addr. : ***</td> <td>1/2</td> </tr> <tr> <td>Dmx Chn. : ***</td> <td></td> </tr> <tr> <td>Dmx Buf. : ***</td> <td>2/2</td> </tr> </table>	Dmx Addr. : ***	1/2	Dmx Chn. : ***		Dmx Buf. : ***	2/2	Set the control parameters for each channel of DMX console when the controller is controlled by DMX console. See 5. DMX512 CONTROL SETTINGS for details.								
Dmx Addr. : ***	1/2															
Dmx Chn. : ***																
Dmx Buf. : ***	2/2															

First Menu	Second Menu	Introduction
SYNC Setting	SYNC Slave / Host Press EN till save	Set main control or sub control.
Brightness	All : *** 1/2 R : *** G : *** B : *** W1 : *** 2/2 W2 : *** W3 : ***	Set the brightness of lighting fixture.
Gamma	** , ** Press EN till save	Set the Gamma correction factor. (Grayscale smoothness level)
Port Level	**** Press EN till save	Set the output signal type as TTL, RS-485, auto.
Addressing	► Pre-set Address Address Check	Set the address parameters of lighting fixtures.
Reset	Restore? Press EN till act	Restore factory setting.
Run Info.	SD-ID : *** 1/6 Pty : *** Copy : *** Baud : *** 2/6 Pag/Fra : *** MRS : *** 3/6 RRS : *** E28 : *** 4/6 E05 : *** EFQ : *** 5/6 JFQ : *** S : *** 6/6 P : ****	Display the project information and SD card performance monitoring.
About	An-380 1/2 **** **** 2/2	Get the information of current version.

4. 5. ARTNET SETTINGS

When the controller is controlling by the Art-Net protocol software (such as Madrix player), we need to set its parameters first, so that it is consistent with the software configuration.

On the Menu Settings, select “Set Art-Net” and press "SPD/EN".

We need to long press “SPD/EN” button to save, and the controller will display “Save Successful”.

The related parameters are as follows.

Selection	Introduction					
Start U.	Set the start universe, range is 0001 - 2048。					
Port Us	Set the universe number, range is 0001 - 0006。					
Channel	Set the channel value of a pixel.					
IC (Chip)	Choose the chip type need to drive. Section below,					
		Page	section		Page	section
		1.	DMX TM1804		2.	TM1908 TM1934
		4.	UCS1903 UCS5603		5.	SM16714P MT1806/MT16703
		7.	SM16804PB SM16709P		8.	SM16711 SM16712P
		10.	SM16813P SN16823E		11.	SM16824E TM1809
		13.	TM1903(SM) TM1903(PTH)		14.	TM1913 TM1914
		16.	UCS1909B UCS1912		17.	UCS2603 UCS2903
		19.	UCS2912 UCS8903		20.	UCS8904 WS2811
		22.	WS2818 FW1903		23.	FW1935 GS8205
		25.	GS8512 GS8513		26.	GS8515 JE2815
		28.	LX3203 P9883/XT1506S		29.	SK6812
					3.	UCS5603 UCS9812
				6.	GW6312 SM16703P	
				9.	SM16714PHT SM16804PB	
				12.	TM1812 TM1814	
				15.	TM1923 UCS1904	
				18.	UCS2904B UCS2909	
				21.	WS2812 WS2813	
				24.	GS8206 GS8208	
				27.	LB1934A LX1003	
Chn. Seq.	Set the color sequence.					
Baud	Set the baud rate of drove chip. SPI: 400K, 600K, 650K, 700K, 800K; DMX: 250K, 500K.					
IP	Set the IP of controller.					

4. 6. SETTING THE ID AND GROUP OF CONTROLLER

It should connect all the controls correctly. Set the ID data and group of the first controller or set by Player, the follow controllers in the same link will be automatically order the continuation of ID and group.

Note,

- A. A.It supports cascade connection of 30 pieces controllers. It takes about 3 seconds to compile the ID of each controller.
- B. B.If the controller does not receive an ID success message after 100 seconds. And it will display E46 .
- C. Ensure all ports of the controller is correctly connected to avoid setting ID failed.
- D. If the second controller set the ID, and the first one will be not set the ID.
- E. Please don not open the Player to avoid setting up failed during the ID set by controller.

4. 6. 1. SETTING ID ON CONTROLLER

1. It should connect all the controllers correctly.
2. Press “MENU” button and select “Set All ID” in the Auto ID. Press “SPD/EN” button to enter it and set the ID.

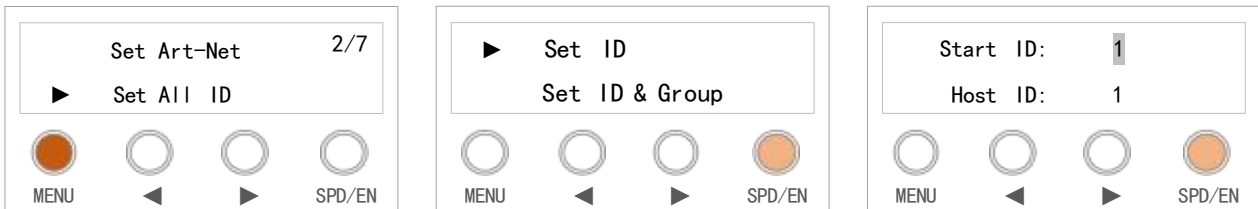

3. Press “▶” and “◀” button to decrease / increase the value.

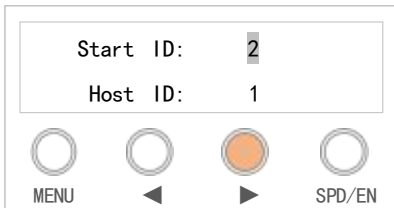

4. Press “SPD/EN” button to save ID if it is confirmed. The subsequent controllers will automatically renew the ID value. When the Settings are complete, they display the number of successful Settings.

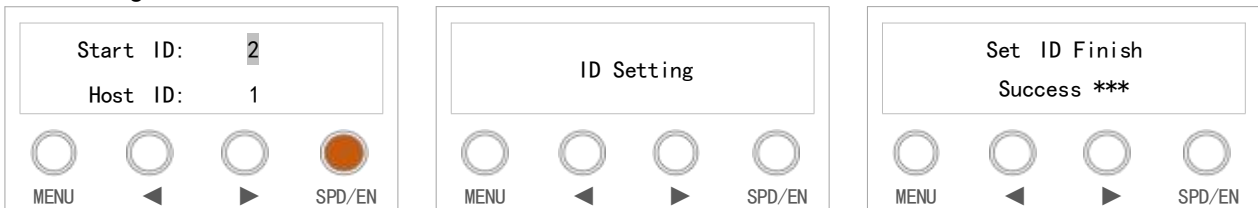

4. 6. 2. SETTING ID, GROUP AND RANK ON CONTROLLER

1. It should connect all the controllers correctly.
2. Press “MENU” button and select Set ID & Group in the SetAll ID. Press “SPD/EN” button to enter.

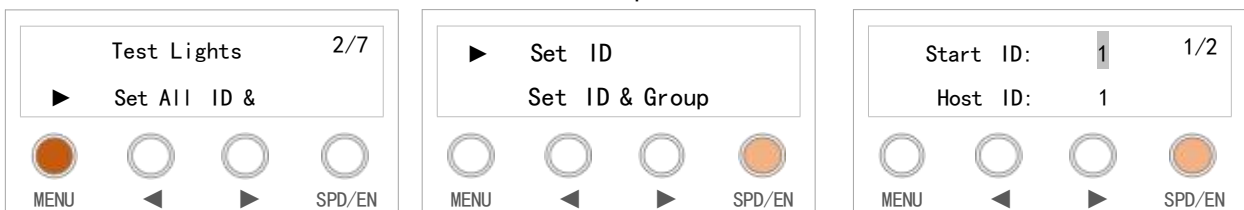

3. Set the start ID, host ID, group though button.

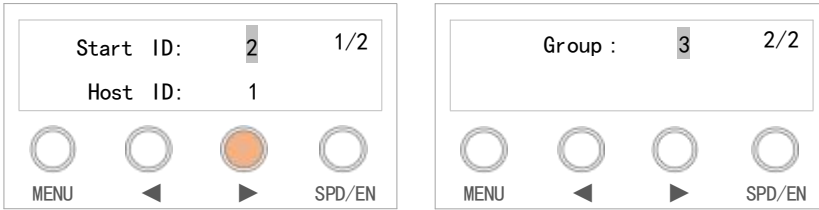

Note, After the configuration is successful, all controllers are slaves except that which ID matches Host. All controllers on the same link are automatically added to the same group. If there are controllers in different groups on the same link, all of them will be configured as the group set this time, and the controller ID will be extended by default.

4. Press “SPD/EN” button to save parameters if it is confirmed. The subsequent controllers will automatically renew the configurations. When the Settings are complete, they display the number of successful Settings.

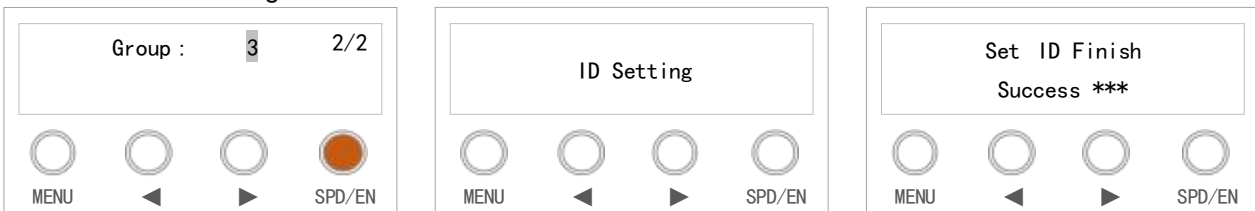

4. 6. 3. ONLINE SETTING BY MAGIC PLAYER

1. It should connect all the controllers correctly. If the controller connects to multiple links through switches, disconnect other links first to avoid configuration errors.
2. Open the Magic Player and click “AN-380 Config” of “Effect” to open the settings window.

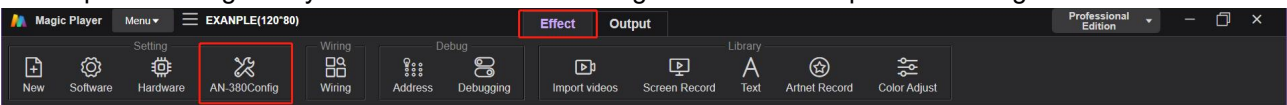

3. In the interface of “ Auto ID ”, we set the first controller’s ID (Fir分组序号 ID), the Group Order, the Host ID, and then click “Send” .

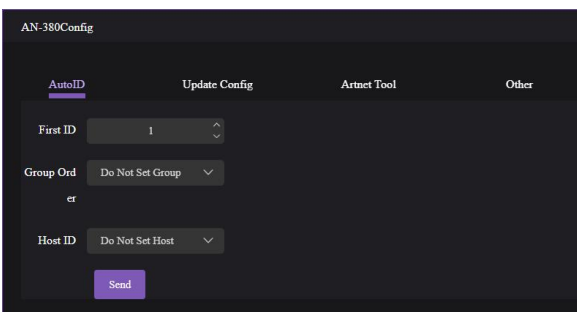

After the configuration is successful, all controllers are slaves except that which ID matches Host. All controllers on the same link are automatically added to the same group.

5. DMX512 CONTROL SETTINGS

Set the channel definition ("one to one" or "ten to one") based on our actual requirements. Different control modes correspond to different functions of channels. Each controller's DMX control function accounts for twelve channels. DMX address set for each controller is $(N-1) * 12 + 1$.

When the controller is controlled by the digital console, DMX buffering needs to be set off. And when controlled by the push rod console, enable buffering.

One to one. (Channel values are incremented by ones.)

Channel	01		02		03		04		05		06		07		08	09		10		11		12	
	Animation (decade)	Animation (unity)	Speed	Brightness (RGBW_100 level)	Brightness (RGBW_6 level)	Brightness (RGBW_100 level)	Brightness (R_100 level)	Brightness (G_100 level)	Brightness (B_100 level)	Brightness (W_100 level)	Control mode	Look mode	Play frame order	Flicker									
Value	Target	Push rod value	Target	Push rod value	Target	Push rod value	Target	Push rod value	Target	Push rod value	Target	Push rod value	Target	Push rod value	Target	Push rod value	Target	Push rod value	Target	Push rod value	Target (insert x frame)	Push rod value	
97	07 ~ 255	99	18 ~ 255	100	100 ~ 255	100	100 ~ 255	100	100 ~ 255	100	100 ~ 255	100	100 ~ 255	100	100 ~ 255	100	100 ~ 255	100	100 ~ 255	100	100 ~ 255	100	100 ~ 255
96	96	80	17	99	99	100	5 ~ 255	99	99	99	99	99	99	99	99	99	99	99	99	99	99	99	99
95	95	50	16	98	98	100	5 ~ 255	98	98	98	98	98	98	98	98	98	98	98	98	98	98	98	98
94	94	30	15	97	97	100	5 ~ 255	97	97	97	97	97	97	97	97	97	97	97	97	97	97	97	97
93	93	20	14	96	96	100	5 ~ 255	96	96	96	96	96	96	96	96	96	96	96	96	96	96	96	96
92	92	15	13	95	95	100	5 ~ 255	95	95	95	95	95	95	95	95	95	95	95	95	95	95	95	95
...	...	12	12	100	5 ~ 255
8	8	10	10	8	8	100	5 ~ 255	8	8	8	8	8	8	8	8	8	8	8	8	8	8	8	8
7	7	9	9	7	7	100	5 ~ 255	7	7	7	7	7	7	7	7	7	7	7	7	7	7	7	7
6	6	8	8	6	6	100	5 ~ 255	6	6	6	6	6	6	6	6	6	6	6	6	6	6	6	6
5	5	7	7	5	5	100	5 ~ 255	5	5	5	5	5	5	5	5	5	5	5	5	5	5	5	5
4	4	6	6	4	4	100	5 ~ 255	4	4	4	4	4	4	4	4	4	4	4	4	4	4	4	4
3	3	5	5	3	3	100	5 ~ 255	3	3	3	3	3	3	3	3	3	3	3	3	3	3	3	3
2	2	4	4	2	2	100	5 ~ 255	2	2	2	2	2	2	2	2	2	2	2	2	2	2	2	2
1	1	3	3	1	1	100	5 ~ 255	1	1	1	1	1	1	1	1	1	1	1	1	1	1	1	1
0	0	0 ~ 3	0	0	0	100	5 ~ 255	0	0	0	0	0	0	0	0	0	0	0	0	0	None	0	

Ten to one. (Channel values are incremented by tens.)

Channel	01		02		03		04		05		06		07		08		09		10		11		12	
	Animation (decade)	Animation (unity)	Speed	Brightness (RGBW_100 level)	Brightness (RGBW_6 level)	Brightness (RGBW_100 level)	Brightness (R_100 level)	Brightness (G_100 level)	Brightness (B_100 level)	Brightness (W_100 level)	Control mode	Look mode	Play frame order	Flicker										
Value	Target	Push rod value	Target	Push rod value	Target	Push rod value	Target	Push rod value	Target	Push rod value	Target	Push rod value	Target	Push rod value	Target	Push rod value	Target	Push rod value	Target	Push rod value	Target (insert x frame)	Push rod value		
90	90 ~ 255	9	90 ~ 255	99	240 ~ 255	100	200 ~ 255	100	200 ~ 255	100	200 ~ 255	100	200 ~ 255	100	200 ~ 255	100	200 ~ 255	100	200 ~ 255	100	200 ~ 255	100	200 ~ 255	
80	80 ~ 89	8	80 ~ 89	80	230 ~ 239	99	198 ~ 199	99	198 ~ 199	99	198 ~ 199	99	198 ~ 199	99	198 ~ 199	99	198 ~ 199	99	198 ~ 199	99	198 ~ 199	99	198 ~ 199	
70	70 ~ 79	7	70 ~ 79	50	220 ~ 229	98	196 ~ 197	98	196 ~ 197	98	196 ~ 197	98	196 ~ 197	98	196 ~ 197	98	196 ~ 197	98	196 ~ 197	98	196 ~ 197	98	196 ~ 197	
60	60 ~ 69	6	60 ~ 69	30	210 ~ 219	97	194 ~ 195	97	194 ~ 195	97	194 ~ 195	97	194 ~ 195	97	194 ~ 195	97	194 ~ 195	97	194 ~ 195	97	194 ~ 195	97	194 ~ 195	
50	50 ~ 59	5	50 ~ 59	20	200 ~ 209	96	192 ~ 193	96	192 ~ 193	96	192 ~ 193	96	192 ~ 193	96	192 ~ 193	96	192 ~ 193	96	192 ~ 193	96	192 ~ 193	96	192 ~ 193	
40	40 ~ 49	4	40 ~ 49	15	190 ~ 199	95	190 ~ 191	95	190 ~ 191	95	190 ~ 191	95	190 ~ 191	95	190 ~ 191	95	190 ~ 191	95	190 ~ 191	95	190 ~ 191	95	190 ~ 191	
30	30 ~ 39	3	30 ~ 39	12	120 ~ 149	11	110 ~ 119	
20	20 ~ 29	2	20 ~ 29	10	100 ~ 109	8	16 ~ 17	8	16 ~ 17	8	16 ~ 17	8	16 ~ 17	8	16 ~ 17	8	16 ~ 17	8	16 ~ 17	8	16 ~ 17	8	16 ~ 17	
10	10 ~ 19	1	10 ~ 19	9	90 ~ 99	7	14 ~ 15	7	14 ~ 15	7	14 ~ 15	7	14 ~ 15	7	14 ~ 15	7	14 ~ 15	7	14 ~ 15	7	14 ~ 15	7	14 ~ 15	
0	0 ~ 9	0	0 ~ 9	8	80 ~ 89	6	12 ~ 13	6	12 ~ 13	6	12 ~ 13	6	12 ~ 13	6	12 ~ 13	6	12 ~ 13	6	12 ~ 13	6	12 ~ 13	6	12 ~ 13	
...	7	70 ~ 79	5	10 ~ 11	5	10 ~ 11	5	10 ~ 11	5	10 ~ 11	5	10 ~ 11	5	10 ~ 11	5	10 ~ 11	5	10 ~ 11	5	10 ~ 11	
...	6	60 ~ 69	4	8 ~ 9	4	8 ~ 9	4	8 ~ 9	4	8 ~ 9	4	8 ~ 9	4	8 ~ 9	4	8 ~ 9	4	8 ~ 9	4	8 ~ 9	
...	5	50 ~ 59	3	6 ~ 7	3	6 ~ 7	3	6 ~ 7	3	6 ~ 7	3	6 ~ 7	3	6 ~ 7	3	6 ~ 7	3	6 ~ 7	3	6 ~ 7	
...	4	40 ~ 49	2	4 ~ 5	2	4 ~ 5	2	4 ~ 5	2	4 ~ 5	2	4 ~ 5	2	4 ~ 5	2	4 ~ 5	2	4 ~ 5	2	4 ~ 5	
...	3	30 ~ 39	1	2 ~ 3	1	2 ~ 3	1	2 ~ 3	1	2 ~ 3	1	2 ~ 3	1	2 ~ 3	1	2 ~ 3	1	2 ~ 3	1	2 ~ 3	
0	0 ~ 9	0	0 ~ 9	0	0 ~ 9	0	0 ~ 1	0	0 ~ 1	0	0 ~ 1	0	0 ~ 1	0	0 ~ 1	0	0 ~ 1	0	0 ~ 1	0	0 ~ 1	0	0 ~ 1	

Dy. Au. is dynamic audio.

Dy. Sou. is dynamic sound. Sp.

Au. is spectrum audio.

Sp. Sou. is spectrum sound.

Positive order indicates that the animation is played from the first frame forward, and reverse order indicates that the animation is played from the last frame forward.

If the channel color sequence of luminaires is not R-G-B-W, the brightness channel shall be switched accordingly.

Flick is set to insert x frames between each frame.

6. ADDRESSABLE OPERATION

6. 1. CHIP SUPPORTED

Chip	Addressing	Custom Channel	Set parameters					
			No signal State	Power-on Setting	Current	Forward	Issue	GAMMA
UCS512A	✓	✗	✗	✗	✗	✗	✗	✗
UCS512B	✓	✗	✗	✗	✗	✗	✗	✗
UCS512C0	✓	✗	✗	✗	✗	✗	✗	✗
UCS512C4	✓	✗	✗	✓	✗	✗	✗	✗
UCS512CN	✓	✗	✓	✓	✗	✗	✗	✗
UCS512D	✓	✗	✓	✓	✓	✗	✗	✗
UCS512E0	✓	✓	✓	✓	✓	✓	✗	✗

Chip	Addressing	Custom Channel	Set parameters					
			No signal State	Power-on Setting	Current	Forward	Issue	GAMMA
UCS512EH	✓	✓	✓	✓	✓	✓	×	×
UCS512G4	✓	×	✓	✓	✓	×	×	✓
UCS512G6	✓	×	✓	✓	✓	×	×	✓
UCS512K	✓	✓	✓	✓	✓	✓	×	✓
UCS512H	✓	×	✓	✓	✓	×	×	✓
DMX512AP	✓	×	×	×	×	×	×	×
SM16511	✓	×	×	×	×	×	×	×
SM16512	✓	×	×	×	×	×	×	×
SM16520	✓	×	×	×	×	×	×	×
SM16500	✓	×	✓	✓	×	×	×	×
SM17500	✓	✓	✓	✓	✓	×	×	×
SM17512	✓	×	✓	✓	✓	×	×	×
SM17522	✓	×	✓	✓	✓	×	×	×
SM18522PH	✓	×	✓	✓	✓	×	×	✓
SM18522P	✓	×	✓	✓	✓	×	×	✓
SW-D	✓	×	×	×	×	×	×	×
Hi512A0	✓	✓	×	×	×	×	×	×
Hi512A4	✓	×	✓	✓	×	×	×	×
Hi512A6	✓	×	✓	✓	×	×	×	×
Hi512E	✓	×	×	×	×	×	×	×
Hi512D	✓	×	×	×	×	×	×	×
TM512AB3	✓	×	×	×	×	×	×	×
TM512AL1	✓	×	×	×	×	×	×	×
TM512ACx	✓	×	×	×	×	×	×	×
TM512AD	✓	×	✓	✓	✓	×	×	×
QED512P	✓	×	×	×	×	×	×	×
GS8511	✓	×	×	×	×	×	×	×
GS8512	✓	×	×	×	×	×	✓	✓
GS8513	✓	×	×	×	✓	×	✓	✓
GS8515	✓	×	×	×	✓	×	✓	✓

6. 2. SUCCESSFULLY ADDRESSED AND SET PARAMETERS

Chip	Lighting color after power on	Addressed		Byte + No signal + No signal		Current parameter		Self-Channel Setting	
		First chip	Other chip	First chip	Other chip	First chip	Other chip	First chip	Other chip
UCS512A	White	Blue	Blue	-	-	-	-	-	-
UCS512A1	White	Blue	Blue	-	-	-	-	-	-
UCS512A2	White	Blue	Blue	-	-	-	-	-	-
UCS512B3	White	Blue	Blue	-	-	-	-	-	-
UCS512C	Custom	White	White	-	-	-	-	-	-
UCS512C0	-	White	White	-	-	-	-	-	-
UCS512C3	Custom	White	White	Red	Red	-	-	-	-

Chip	Lighting color after power on	Addressed		Byte + No signal + No signal		Current parameter		Self-Channel Setting	
		First chip	Other chip	First chip	Other chip	First chip	Other chip	First chip	Other chip
UCS512C4	Custom	White	White	Red	Red	-	-	-	-
UCS512CN	Custom	Yellow	White	Yellow	Power on	-	-	-	-
UCS512D	Custom	Yellow	White	Yellow	Power on	Yellow	Red	-	-
UCS512E0	Custom	Yellow	White	Yellow	Power on	-	-	Yellow	Green
UCS512EH	Custom	Yellow	White	Yellow	Power on	Yellow	Red	Yellow	Green
UCS512G4	Custom	Yellow	White	White (Or custom)	White (Or custom)	White	White	-	-
UCS512G6	Custom	Yellow (Or custom)	White (Or custom)	White (Or custom)	White (Or custom)	White	White	-	-
DMX512AP	-	White	White	-	-	-	-	-	-
SM16512	-	Green	Green	-	-	-	-	-	-
SM16511	-	Green	Green	-	-	-	-	-	-
SM16520	-	Green	Green	-	-	-	-	-	-
SM16500	Custom	Red	Green	Red	Power on	-	-	-	-
SM17500	Custom	Red	Green	Red	Power on	Red	Yellow	Red	Purple
SM17512	Custom	Red	Green	Blue	Blue	-	-	-	-
SM17522	-	Red	Green	Red	Blue	Red	Yellow	-	-
SM18522	Custom	Red	Green	Blue	Blue	-	-	-	-
SM18522PH	-	Red	Green	Red	Blue	Red	Yellow	-	-
SW-D	-	Yellow	Green	-	-	-	-	-	-
Hi512A4	Custom	Red	Green	Red_	Green	-	-	-	-
Hi512A6	Custom	Red	Green	Red	Green	-	-	-	-
Hi512A0	-	White	White	White	White	-	-	-	-
Hi512D	-	Red	Green	Green	Green	Green	Green	-	-
Hi512E	-	Red	Green	Green	Green	Green	Green	-	-
TM512AB3	White	Blue	Blue	-	-	-	-	-	-
TM512AL1	White	Blue	Blue	-	-	-	-	-	-
TM512AC0	-	White	White	-	-	-	-	-	-
TM512AC2	Custom	White	White	-	-	-	-	-	-
TM512AC3	Blue	White	White	-	-	-	-	-	-
TM512AC4	Blue	White	White	-	-	-	-	-	-
TM512AD	Blue	Yellow	White	Yellow	Power on	Yellow	Red	-	-
GS8512	Custom	Red	Cyan	-	-	-	-	-	-
GS8513	Red+Cyan	Red	Cyan	-	-	-	-	-	-
GS8515	Red+Cyan	Red	Cyan	-	-	-	-	-	-

6. 3. ONLINE ADDRESSING BY MAGIC PLAYER

1. It should connect all the devices correctly. Open the Magic Player and click “Address” of “Effect” to open the addressing window.
2. Select the controllers needed to address in the interface.
3. Click “Apply Checked Controller” after setting the pixel of chip, the start address value.
4. Click “Address Checked Controller” to send the addressing parameters to all controllers. And it will show “Finish addressing” when finish addressing.

Note,

- 1) We can select a single port, a single controller or all controllers to send addressing instructions according to the actual application.
- 2) The addressing successful is according to the luminaire light color.

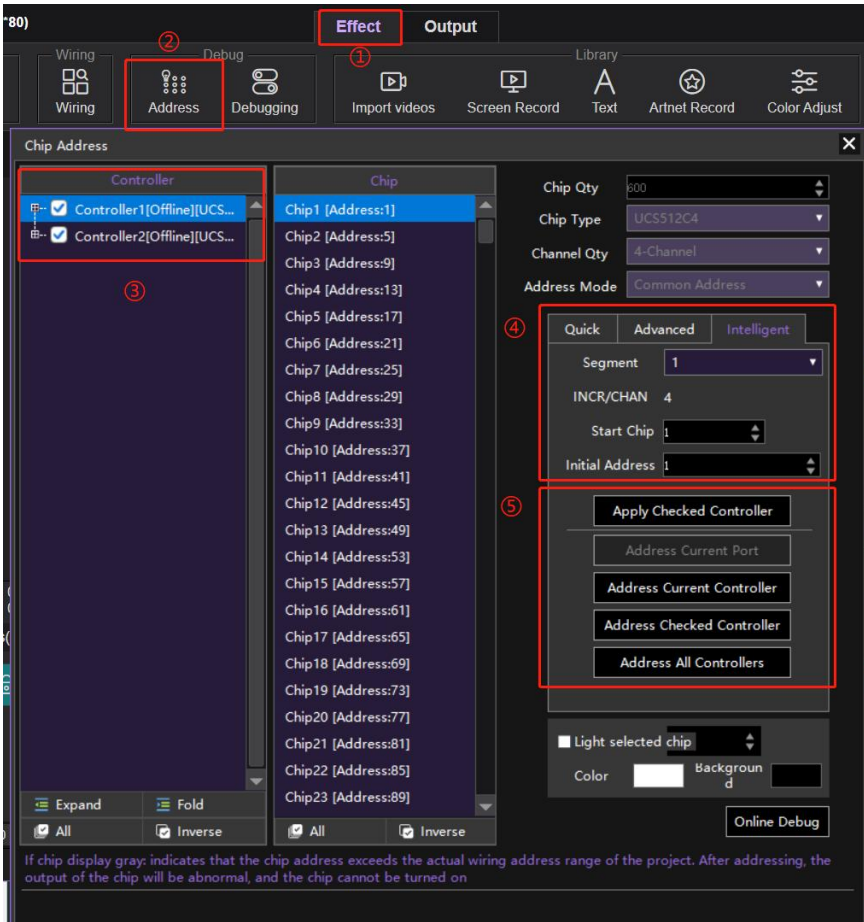

Selection	Introduction
Apply Checked Controller	Click and save the chip date of all checked controllers.
Address Current Port	Click and address the chips of selected port.
Address Current Controller	Click and address the chips of selected controller.
Address Checked Controller	Click and address the chips of all checked controllers.
Address All Controller	Click and address all chips.

6. 4. ADDRESSING ON CONTROLLER BY SD CARD FILE

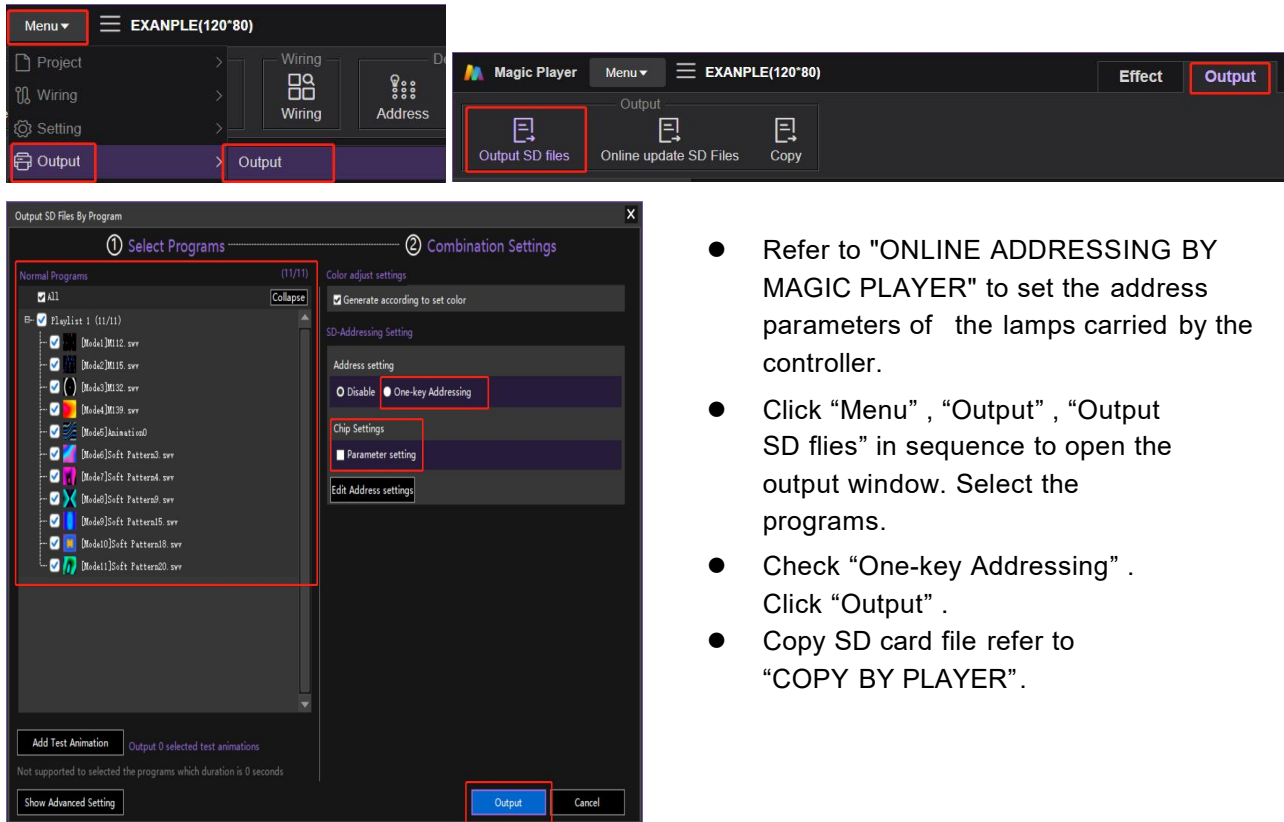

- Refer to "ONLINE ADDRESSING BY MAGIC PLAYER" to set the address parameters of the lamps carried by the controller.
- Click "Menu", "Output", "Output SD files" in sequence to open the output window. Select the programs.
- Check "One-key Addressing". Click "Output".
- Copy SD card file refer to "COPY BY PLAYER".

- Insert SD card and power on.
- Long press "MENU" to enter the menu settings. Select Addressing and press "SPD/EN". Select Pre-set Address and press "SPD/EN" to start addressing. It shows "One Key Addr OK" when it finish addressing.

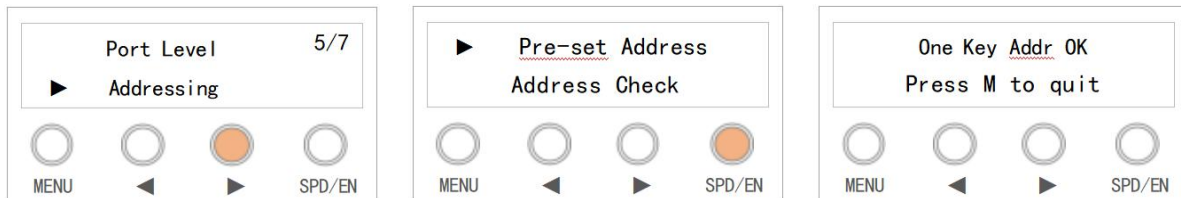

Note, the addressing successful is according to the luminaire light color.

6. 5. ADDRESSING CHECK

After the luminaire has been written to the address, we need to verify twice that the luminaire has successfully written to the address parameter.

6. 5. 1. CHECK THE ADDRESSING ON CONTROLLER

1. Select Addr. Check in the Addressable under the menu settings to enter.
2. Press "SPD/EN" to move the cursor and press "◀" or "▶" to set value.



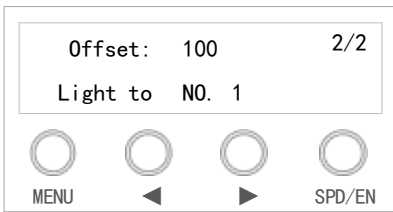

6.5.2. CHECK THE ADDRESSING BY PLAYER

Method 1, under the “Effect” in Magic Player click “Debugging” to open “Pixel Test” . Set the a Point Count and Operation mode to light up luminaires.

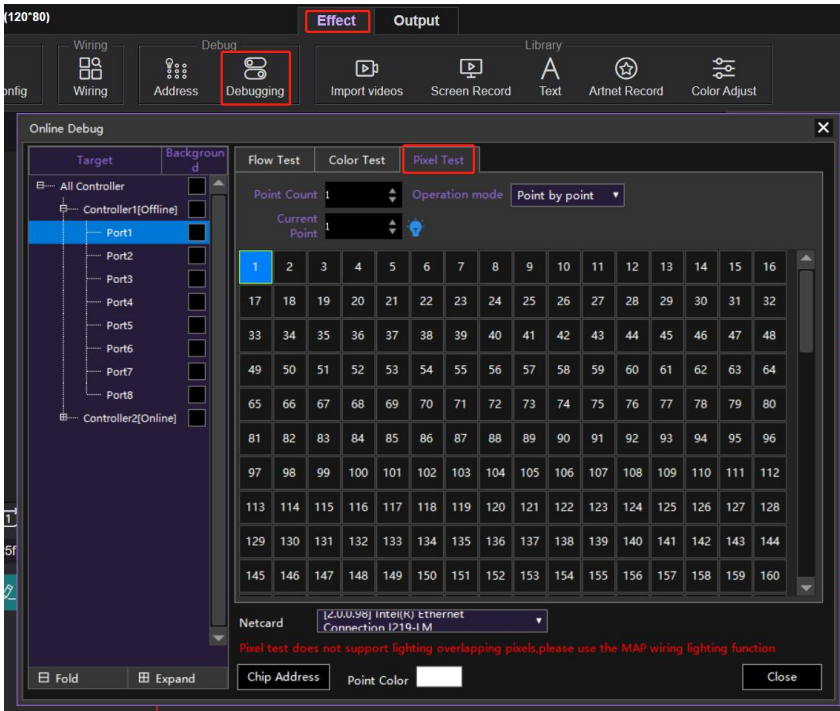

Method 2, under the “Effect” in Magic Player click “Address” and check the “ Light selected chip” in the pop window.

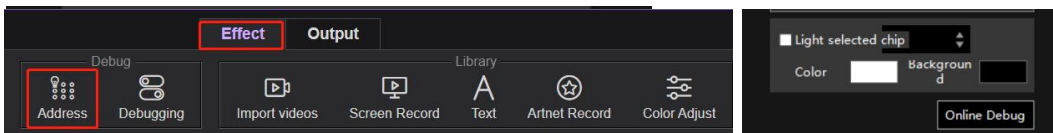

Note, check “ Light selected chip” , the player will light up the luminaire which chip is select.

7. IP SETTING ON PC

When the controller connects to a computer, assign a static IP address to the network adapter.

1. Open “Network Connection” on the PC, right click “Local Connection” and select “Properties” .

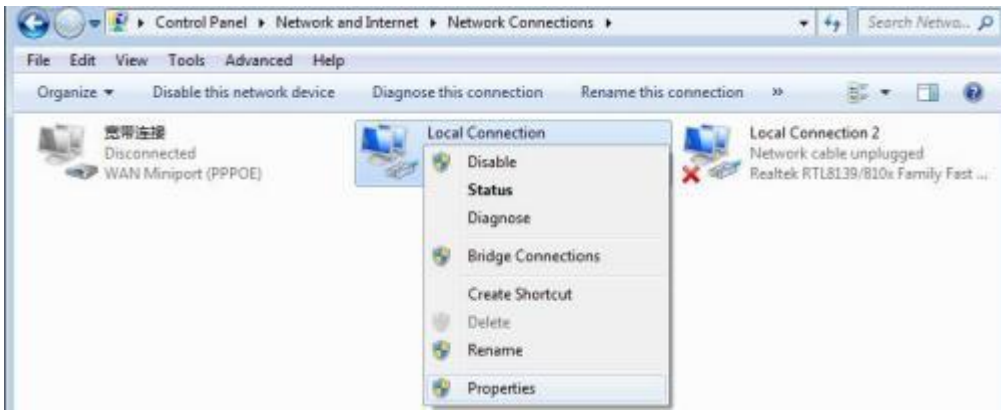

2. Select Internet Protocol (TCP/IP), then click “Properties”. Set the IP address as below.



3. Click “OK” after the setting is finished.

8. ART-NET SETTINGS ON SOFTWARE

In addition to setting art-net parameters on the controller, it can also be set online through the software ArtNet Tool.

8.1. OBTAINING CONTROLLER INFORMATION

1. Click “网卡设置” and select the network adapter for connecting to the controller. (Set the static IP address of the network adapter that does not conflict with the controller in advance.)
2. Click “退出”, and click “搜索” to obtain the controllers’ information.



8.2. SET BASIC PARAMETERS OF THE CONTROLLER

1. Select the controllers which we want to set after the controllers are correctly connected and read.
2. Click "更新勾选控制器参数" to update after setting IP address, chip type, baud rate, channel.



We can click "快速设置" to set the same parameter to multiple selected controllers.

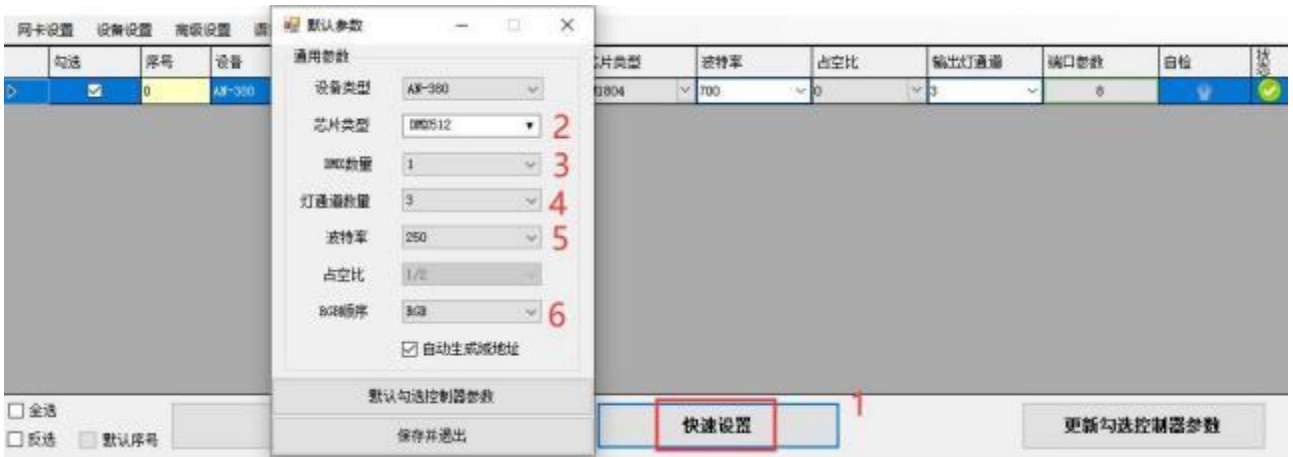

3. We can set the number of channels and universes for each port on the "端口参数" interface.



4. Click "保存并退出" to save.

8. 3. SELF-CHECKING FUNCTION

1. Select the controllers which we want to set after the controllers are correctly connected and read.
2. Click the light gun to light it up. (Yellow indicates that the self-test effect is playing, and gray indicates that the self-test is stopped.)



9. OPERATIONS RELATED TO SD CARD FILES

9.1. GENERATE THE SD CARD FILE

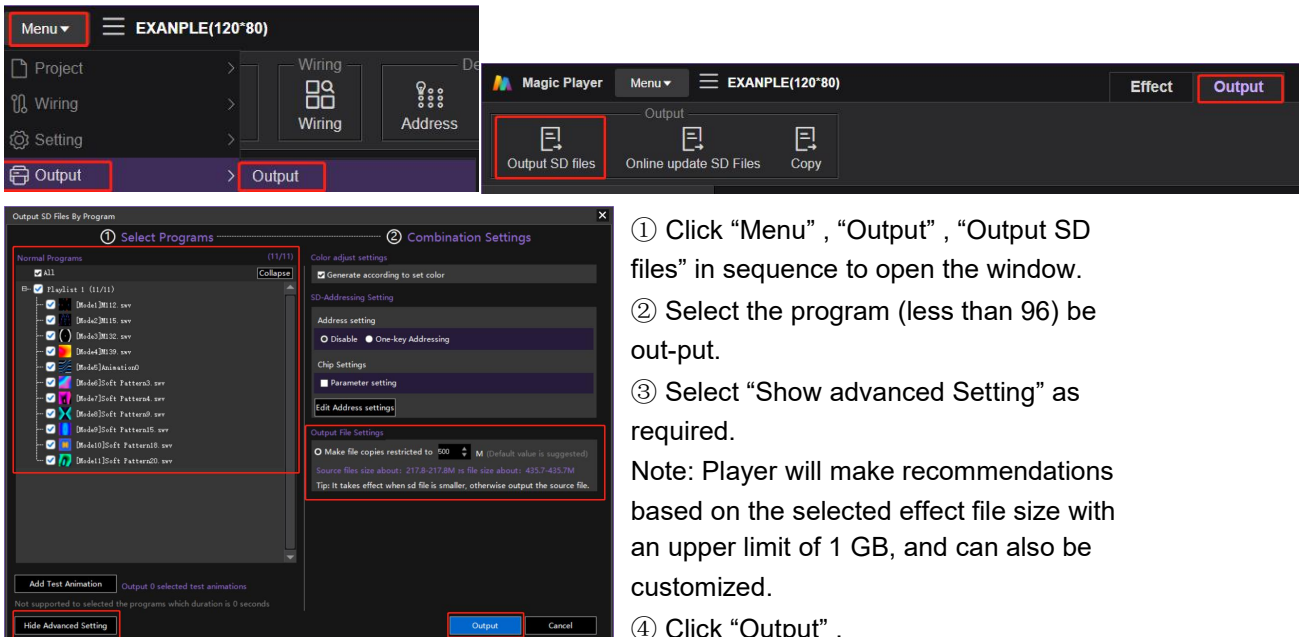

- ① Click “Menu” , “Output” , “Output SD files” in sequence to open the window.
- ② Select the program (less than 96) be out-put.
- ③ Select “Show advanced Setting” as required.
- ④ Click “Output” .

Note: Player will make recommendations based on the selected effect file size with an upper limit of 1 GB, and can also be customized.

Note: The expanded file size does not exceed 80% of the total capacity of the SD card. For a 32GB card, ensure that the file size is within 29GB.

The calculation formula is: $\text{File copies} = \frac{\text{total SD card capacity (G)} \times 1024 \times 80\%}{\text{source file size (M)}} - 1$
For example: 4G SD card storage, source file size is 100M, it needs to set 31 copies.

9. 2. UPDATES THE SD CARD ONLINE THROUGH NETWORK CABLE

- ① Click “Online update SD Files” under the “Update Config” .
- ② Select the online controller which needs to update.
- ③ Click “Send SD effect” .

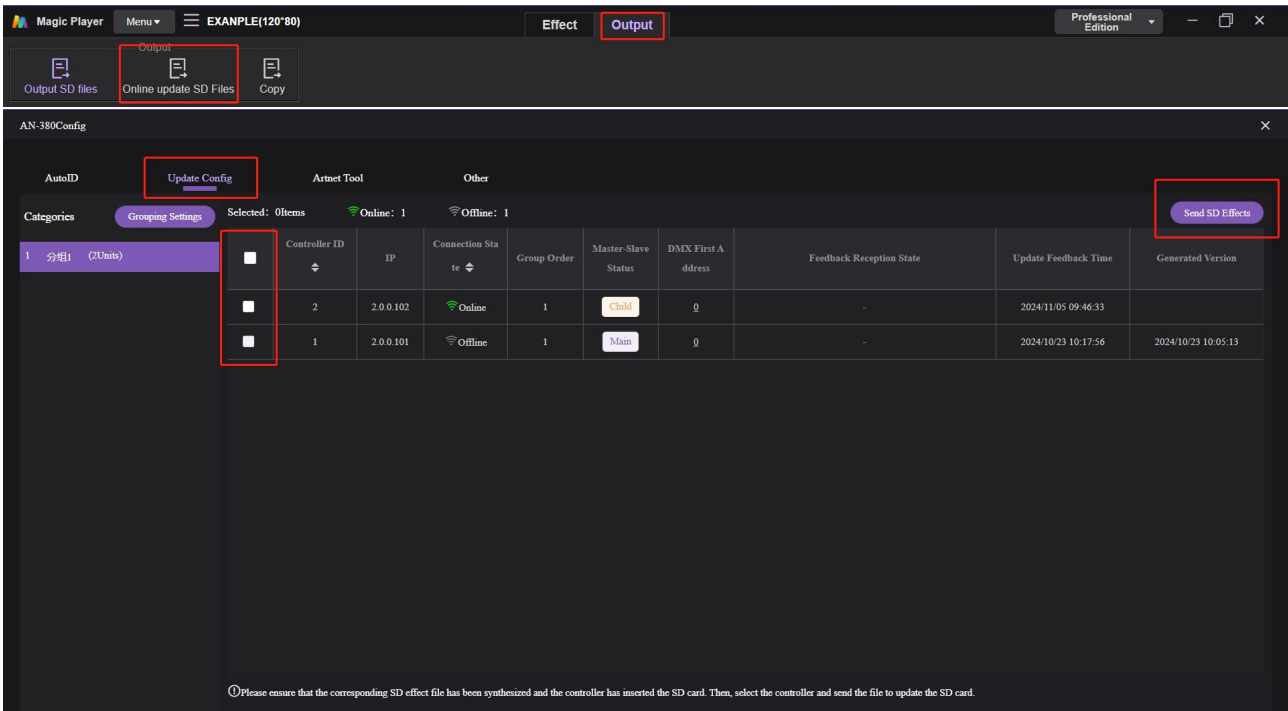

9. 3. COPY BY LED PLAYER

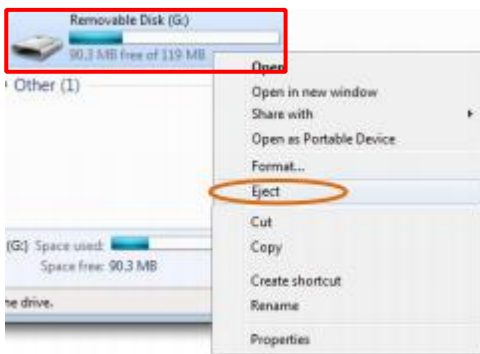
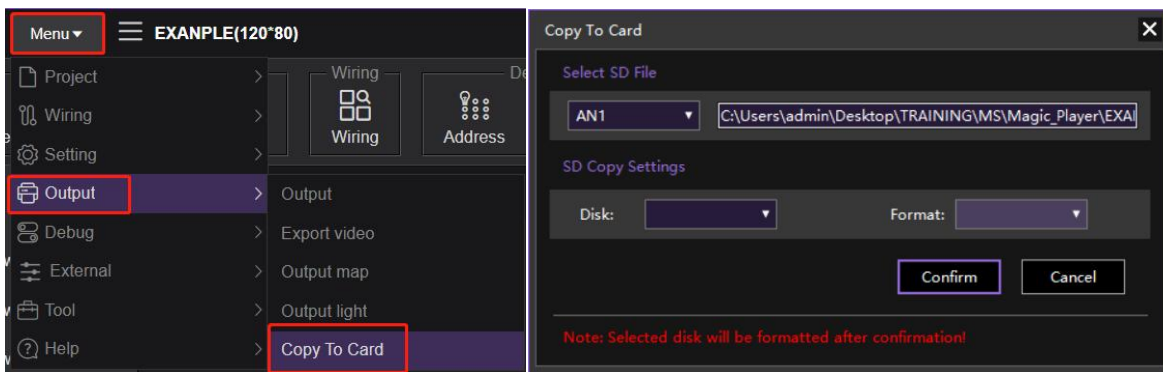

- ① Click “Menu” , “Output” , “Copy to Card” in sequence to open the window.
 - ② Select the controller number to be copied from the drop-down list.
 - ③ Click “Confirm”.
- Right click removable disk and select “ Eject” if finishing copy.

9. 4. SD CARD COPY

1) Right click the disk where the SD card locates.

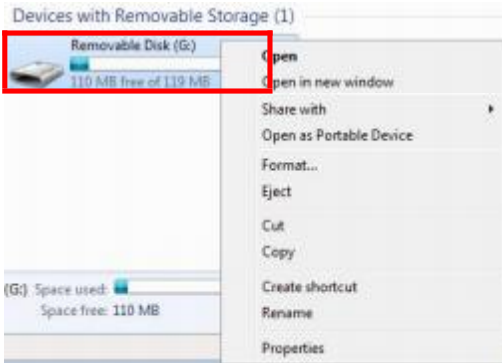

2) Select FAT and 32kb unit (Can check "Quick Format") and click

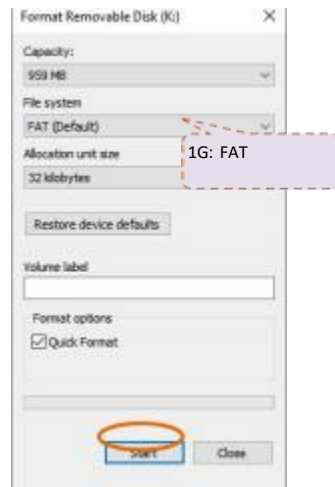

3) Right click A8_*.Bin file, send the file to Removable Disk.

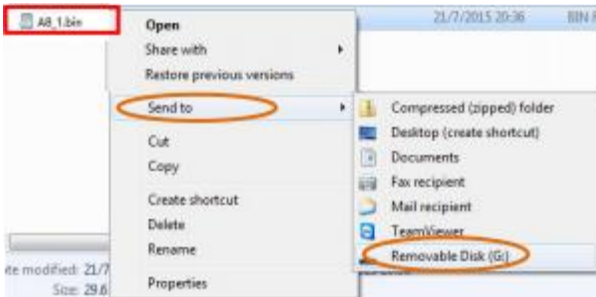

4) Right click removable disk and select "Eject".

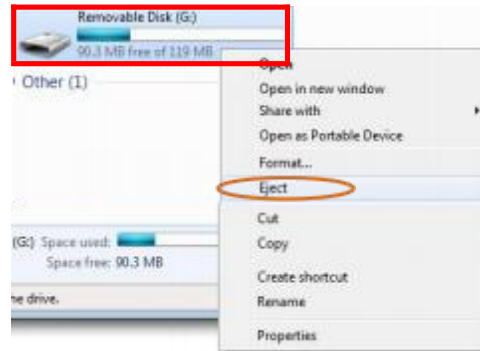



10. ERROR CODE AND TROUBLE SHOOTING

Display		Measure
E01	No SD card or SD card port is broken.	<ol style="list-style-type: none"> 1. Insert the SD card. 2. If an error occurs when inserting the SD card, the SD card holder is damaged. Contact us.
E02	SD card no response or breakdown.	<ol style="list-style-type: none"> 1. Please replace the new SD card. 2. If an error occurs when inserting the SD card, the SD card holder is damaged. Contact us.
E03	There is no file in the SD card or SD card is breakdown.	Copy SD card file again.
E18	The number of loaded pixels exceeds the upper limit.	Please reduce the number of project pixels.
E19	Invalid file, please check whether the project and master control match.	Please check whether the project and master control match.
E27	The SD card has too many bad areas.	Please replace the new SD card.
E29	SD card format unit is incorrect,	Please use "32K" to reformat and copy the card.

Display		Measure
	please use "32K" to reformat and copy the card.	
E30	The controller is damaged.	The parameters of the Flash primary area and backup area are saved incorrectly. Contact us.
E37	Multiple hosts in the same group are connected to the same link.	Check whether the primary/secondary Settings are correct.
E38	The file SD.BIN does not match the ID of the controller.	Copy the correct SD card file again.
E39	Lost saved parameters	<ol style="list-style-type: none"> 1. Saved parameters are lost due to unknown exceptions, and running parameters are restored to default values. 2. It is normal that the parameters are saved and restored to default values after firmware upgrade.
E46	Auto addressing is timed out.	<ol style="list-style-type: none"> 1. Ensure the controller's wiring is correct. 2. Ensure the number of controllers in a link to less than 30. 3. Ensure all controllers are powered on. Wait 10 seconds and try again. 4. Ensure the faulty machines exist on the network.
E51	The slave effect file does not match the host	Copy the correct SD card file again.

11. FITTINGS

Shows	Item	Number	Remark
	SD Card (1G)	1	
	Power line	1	
	3P terminal blocks	8	