



# E108 MANUAL

Version: 3.8

2025-7

# CONTENTS

1. FUNCTION OVERVIEW .....	1
2. PRODUCT INFORMATION .....	1
2.1. TECHNICAL PARAMETERS .....	1
2.2. COMPONENT .....	2
2.3. PORT INTRODUCTION .....	2
3. CONNECTION MODE .....	3
3.1. CONNECTION DIAGRAM OF CONTROLLER .....	3
3.2. CONNECT WITH LIGHTING FIXTURE .....	3
3.3. PRECAUTIONS FOR GIGABIT SWITCH APPLICATION .....	4
3.4. OPTICAL FIBER COMMUNICATION .....	4
3.5. TRANSMISSION DISTANCE .....	5
4. BASIC OPERATION .....	5
4.1. MENU INTRODUCTIION .....	5
4.2. PARAMETERS SETTINGS .....	6
4.2.1. <i>STARTING UP DISPLAY</i> .....	6
4.2.2. <i>ID SETTINGS</i> .....	6
4.2.3. <i>AUTO SET ID OF CONTROLLER</i> .....	6
4.2.4. <i>CONFIGURE ADDRESSING</i> .....	8
5. IP ADDRESS SETTING (PC) .....	8
6. ADDRESSING BY LED PLAYER .....	9
7. APPENDIX (CHIPS ADDRESSING) .....	10
7.1. CHIP SUPPORT .....	10
7.2. UCESSFULLY ADDRESSED AND SET PARAMETERS .....	11
8. ART-NET SETTINGS ON SOFTWARE .....	13
8.1. OBTAINING CONTROLLER INFORMATION .....	13
8.2. SET BASIC PARAMETERS OF THE CONTROLLER .....	13
9. ERROR CODE AND TROUBLE SHOOTING .....	14
10. PARTS LIST .....	16

# 1. FUNCTION OVERVIEW

1. Support access and control by LED Player software or Master controller.
2. It supports 1,000,000 channels or cascade connection of 400 pieces controllers.
3. Support quickly address function, LED Player software search equipment.
4. Use button of the controller to set the IP address of the controller.
5. 8-port data-independent signal output (with the isolation), control variety of regular chips in LED digital tube screen, LED pixel light screen, and etc.

SW Single chip: D\*\*S, D\*\*J.

SPI: TM180\*-400K/800K, UCS19\*\*, UCS29\*\*, WS2811/12, TLS3001(1Mhz), SM167\*\*, SM16823E, SM16824E.

DMX512: SW-D, SW-U, UCS512A/B/C0/C4/D/E0/EH/G4/G6, DMX512AP/SM512, SM16500P/511/512, SM17500P/512P/522P, SM17512/522, SM18522P/PH, Hi512A0/A4/A6, TM512AB3/AL1/ACx/AD/AE, QED512P, GS8512/513/515,

standard DMX512 lighting fixture on the market.

Please refer to the "CHIP SUPPORT" section for addressing.

Break-point resume: UCS5603, WS2818, GS8206, P9883, TM1914, XT1506S.

65536 gray scale: UCS8903, UCS8904, UCS9812, SM16813.

6. With professional LED Player software, user can make any effect by themselves.
7. The load capacity of different lighting fixtures is different. (If frame frequency is not required, load capacity of each channel can be increased independently, and must test it in the factory.)

## 2. PRODUCT INFORMATION

### 2.1. TECHNICAL PARAMETERS

Cover material: Iron

Input voltage: AC100V - 240V

Input signal: SW Ethernet Protocol

Output port: E108: TTL & RS-485 \* 8 ports

Pixel driven: LED Player software:

Single chip: 512 channels ×8 ports, SPI chip: 3072 channels ×8 ports,

Standard DMX512: 512 channels ×8 ports, Extensible DMX: 1024 channels ×8 ports,

Break-point resume: 2160 channels ×8 ports, 65536 gray scale: 2160 channels ×8 ports.

Output power: 5W

Working temperature: -25°C ~ 70°C

Relative humidity: ≤50%

Connecting mode: In parallel (address manually)

IP grade: IP20 (Prevent people from touching the components inside electrical appliance, prevent object which diameter is more than 12.5mm from getting in, no special protection to water or moisture.)

Working environment: 1. Please do not install the controller in magnetic, high pressure, high temperature or seriously wet environment.

2. Please do connect the earth safely in order to reduce risks of fire and damage which cause by short circuit.
3. Please ensure AC100-240V power supply is used, and same polarity is connected between transformer and controller in order to guarantee the proper supply voltage.
4. No waterproof function in the control system, please pay attention on rainproof and waterproof during installing.

Net weight: 1 kg  
 Size: L253\*W137\*H45  
 Unit mm

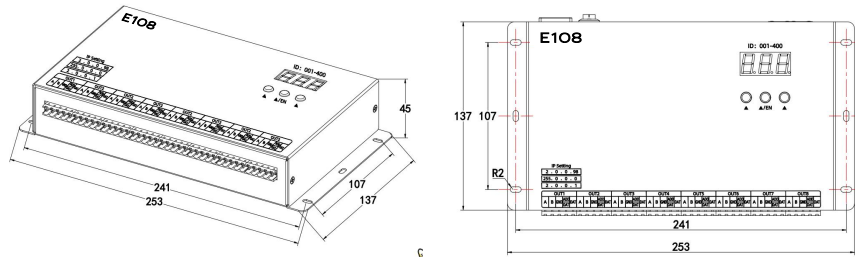

## 2.2. COMPONENT

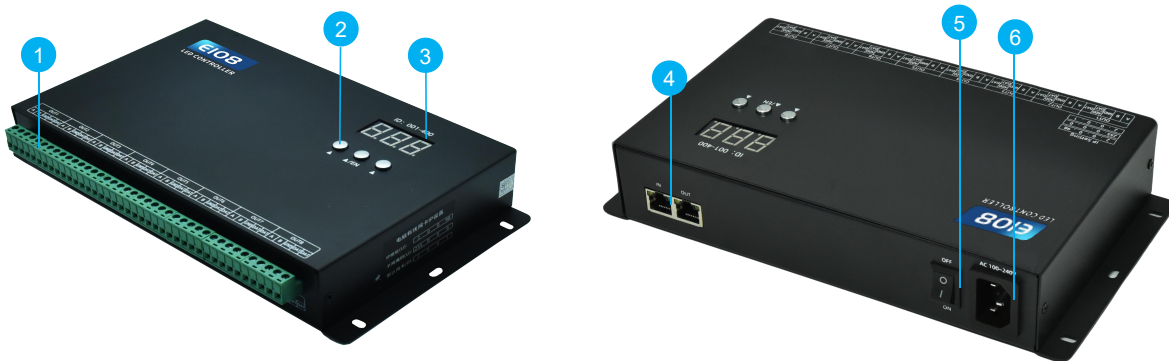

- ① Output control lighting fixture      ② Button      ③ Nixie display  
 ④ Uplink port      ⑤ Power switch      ⑥ Power input AC100-240V

## 2.3. PORT INTRODUCTION

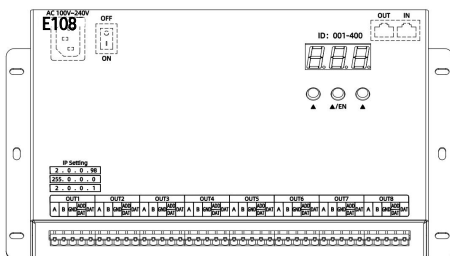

Port	Description	
IN	Connect with PC / Master controller / E108 controller.	
	Top left light	Signal indicator, flicker when the 8 input port output the correct signal.
	Top right light	Nonuse.
OUT	Connect with EN controller.	
	Top left light	Receive data indicator, flicker when the control gain the data completely..
	Top right light	Nonuse.

### 3. CONNECTION MODE

#### 3.1. CONNECTION DIAGRAM OF CONTROLLER

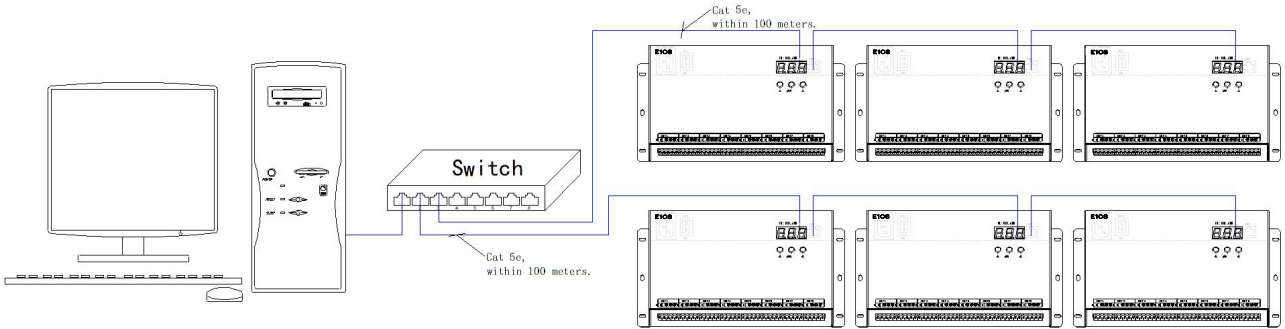

#### 3.2. CONNECT WITH LIGHTING FIXTURE

Please connect the cables in accordance with silk print on lighting fixture.

DMX lamps with AB line control and AB line code writing

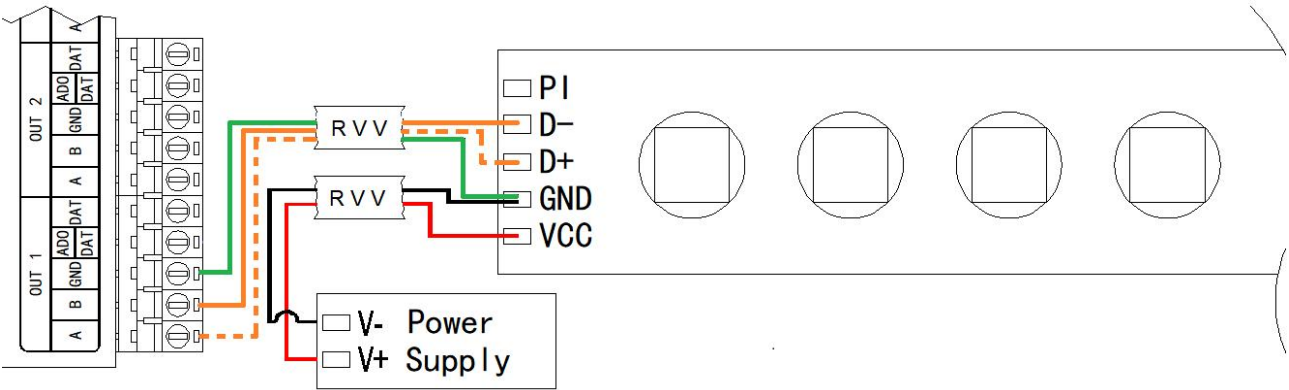

DMX lamps with AB line control and address line code writing

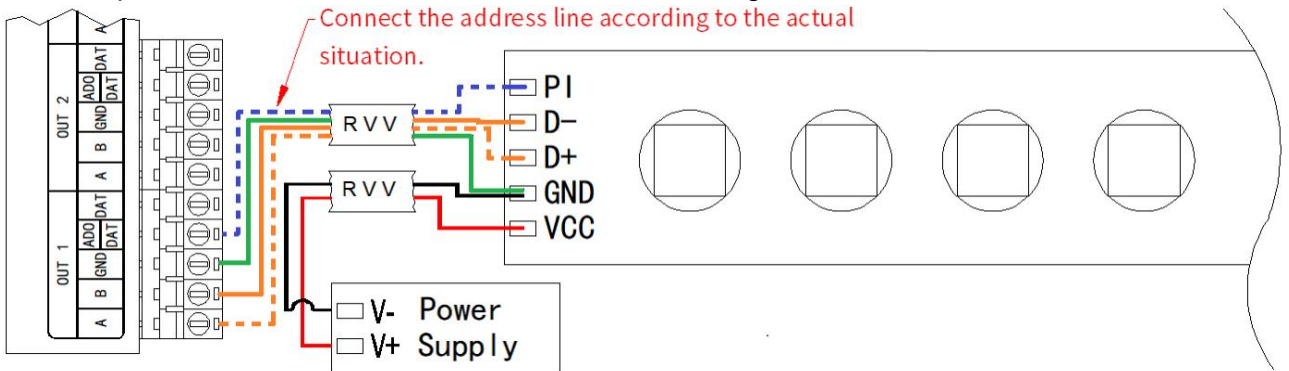

Output control TTL signal, address line write code DMX lamps and lanterns

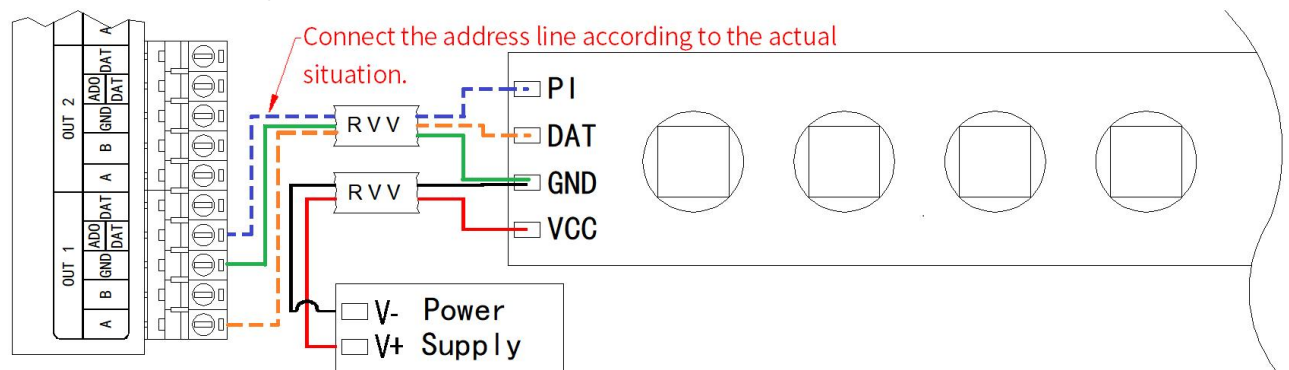

### SPI single-wire lamps

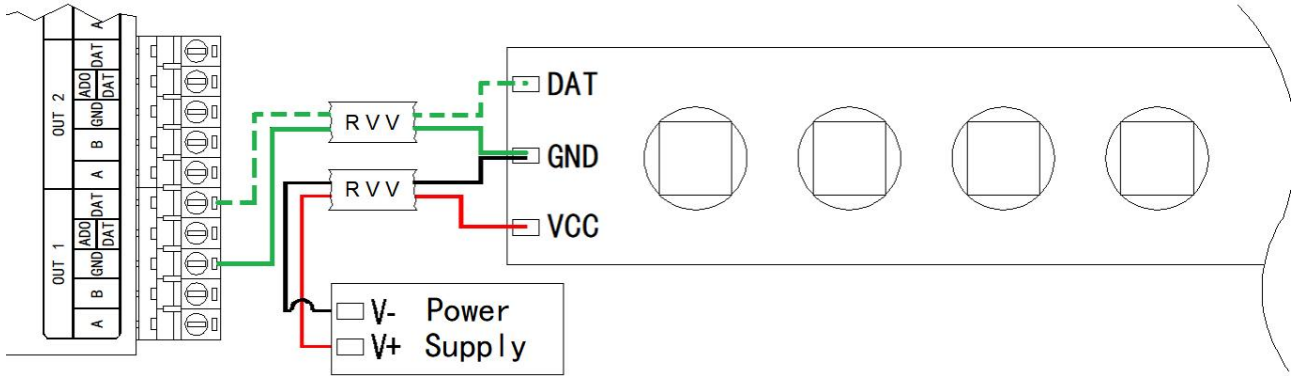

★ Signal cables connection cautions:

1. Use UTP—Unshielded Twisted Pair (resistance per 100M<10Ω), low quality Ethernet cables, telephone cables and copper wires are unavailable.
2. Use one group twisted pair, suggest green + green white or orange + orange white. The quality and color of the cable are very important. Blue and brown wires greatly influence the signal transmission. Please don't use several groups of twisted pairs together.
3. Controller signal output GND must connect directly with input GND of lighting fixture. Cannot connect with lighting fixture through power supply.
4. Switch on the controller after all hardware signal and power cables are connected. Please don't CONNECT / DISCONNECT the signal cables while the controller is power on; avoid back-flow current burning circuit and components of output port.

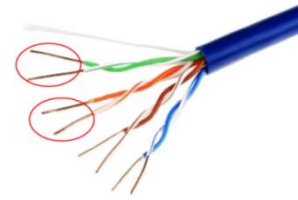

### 3.3. PRECAUTIONS FOR GIGABIT SWITCH APPLICATION

When the gigabit switch is used to expand more than 300,000 on-load channels, note the following.

1. Set the output mode of unicast for LED Player.
2. Based on the transmission speed between controllers is 100Mbps, a single port of the Gigabit switch cannot carry more than 300,000 channels at 25fps, otherwise the frame rate will slow down.
3. If the controller is not fully connected during the debugging phase, the frame rate may slow down. Because the data of the unconnected controller will be broadcast to all switch ports, resulting in network congestion.
4. In the normal working state, a controller is damaged or poorly connected and it is connected to more controllers, the frame rate may slow down. Because the disconnected controller data will be broadcast to all switch ports, resulting in network congestion.

### 3.4. OPTICAL FIBER COMMUNICATION

Must use single mode transceivers. User can use single fiber or double fiber (alternative) according to on-site condition. The double fiber transceiver must be connected with two optical fibers.

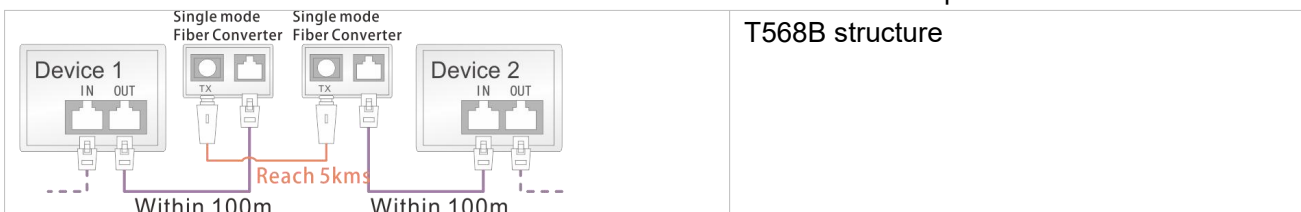

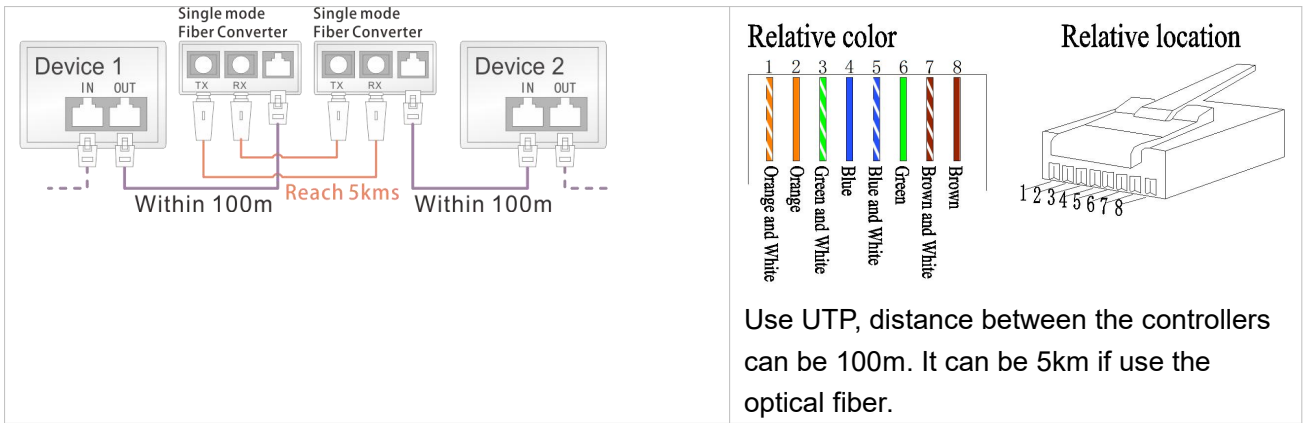

### 3.5. TRANSMISSION DISTANCE

Transmission Type	Signals	Medium	Distance (M)	Remark
MP / PC → EN controller	100M	UTP CAT5e	50-80	
EN controller → EN controller	Ethernet			
EN controller → DMX lighting	RS-485	UTP CAT5e	30-50	The address wire must be within 5m.
DMX lighting → DMX lighting		Core wire	1-20	
EN controller → SPI lighting	TTL	UTP CAT5e	5-20	Controllable pixels reduce if wire is over 5m.
DMX lighting → DMX lighting		Core wire	1-5	
SPI lighting → SPI lighting	TTL	UTP CAT5e	1-2	Pixels controlled less if over 1m.
		Core wire	0.1-1	

## 4. BASIC OPERATION

### 4.1. MENU INTRODUCTIONS

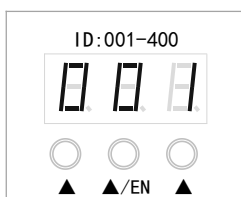

Button		Description
▲ (left)	Long press	Non-support.
	Short press	Increase the left data. (Range is 0-4.)
▲/EN	Long press	1) enter the ID setting. 2) Confirm ID.
	Short press	Increase the middle data. (Range is 0-9.)
▲ (right)	Long press	Non-support.
	Short press	Increase the right data. (Range is 0-9.)
▲/EN +	Long press	Auto addressing.
▲ (right)	Short press	Non-support.
▲ (left) +	Long press	Configure addressing.
	Short press	Non-support.

## 4.2. PARAMETERS SETTINGS

### 4.2.1. STARTING UP DISPLAY

1. Power on when PC connects with controller by network cable. Controller nixie display will show “- - -”. After few seconds, it jumps to the ID address information and the network of the controller is accessible.

Note: When the controller-level networking ports are not all connected to the main control or sub-control, the system will briefly prompt "E44" and enter the main interface, which is normal.

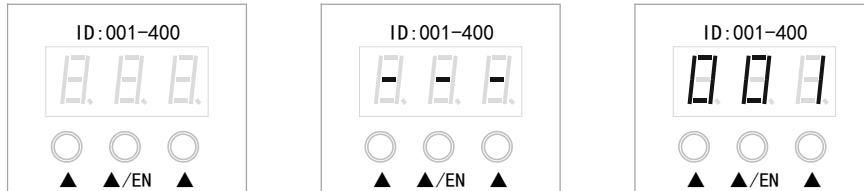

### 4.2.2. ID SETTINGS

1. Long press “▲/EN” button and enter ID Setting. The lower right of each value of the digital tube flick “•”.

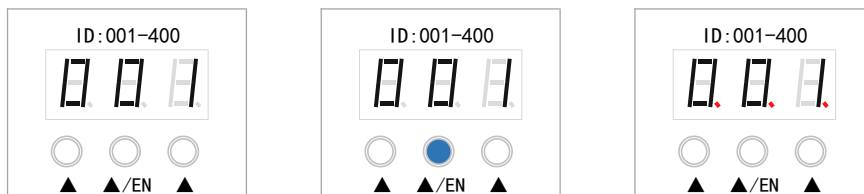

2. Press “▲” under each value to increase data. (From 0 to 9, and it will return 0 while get to 9. The range is 001-400.)

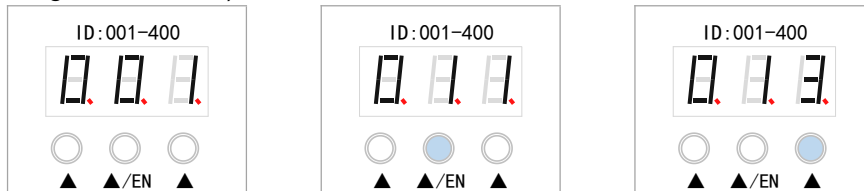

3. Long press “▲/EN” button to save ID if it is confirmed.

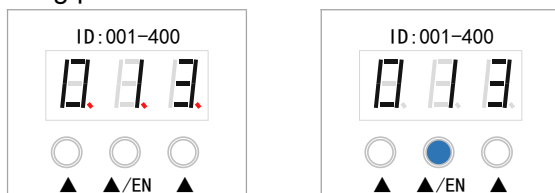

Note, In the process of setting ID, the key does not operate for 30s, It will exit the setting state and restore the ID.

### 4.2.3. AUTO SET ID OF CONTROLLER

It should cascade all the sub-controls together. Set the ID data of the first controller or set by LED Player, the follow controllers in the same link will be automatically order the continuation of ID.

Note,

- A. A maximum of 30 sub-controller IDs can be addressed at a time. The duration of setting depends on the number of sub-controllers. It takes about 3 seconds to write the ID of each sub-controller
- B. Please don not open the LED Player to avoid setting up failed during the ID set by controller.
- C. Automatic ID compilation is only effective for the current sub-control and its subsequent access sub-control, and the previously accessed sub-control is not affected by this operation.
- D. Before operating the automatic ID function, please ensure that the cascade connection is correct. The IN port of the current sub-control should be connected to the OUT port of the previous

sub-control, and the OUT port of the current sub-control should be connected to the IN port of the next sub-control.

**Set the ID by the first controller.**

1. Long press “▲/EN” button and enter ID Setting. The lower right of each value of the digital tube flick “.”.

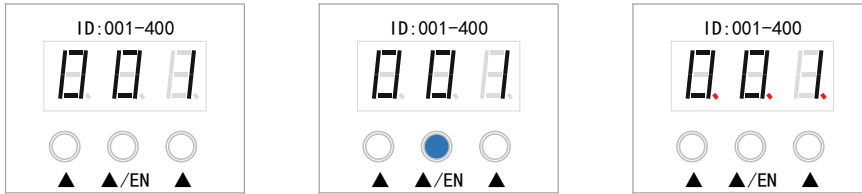

2. Press “▲” under each value to increase data. (From 0 to 9, and it will return 0 while get to 9. The range is 001-400.)

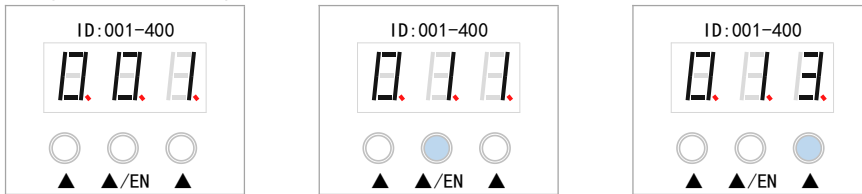

3. Long press “▲/EN” and “▲(right)” if confirm the ID value. The value of the nixie tube screen enters the 80-second countdown (keep blinking). And it issues automatic address ID instruction to subordinate sub - controllers. After all subordinate sub-controllers receive the instruction, the nixie tube enters the flashing state.

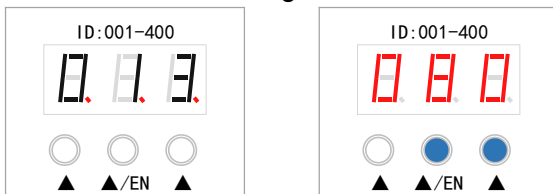

4. When all sub-controllers finish automatically writing the ID address, the nixie tube of the first sub-controller will speed up flashing and display the number of sub-controllers successfully programmed into the ID automatically.

After 10 seconds, all the nixie tubes of the sub-control will blink and stop and display the corresponding ID code.

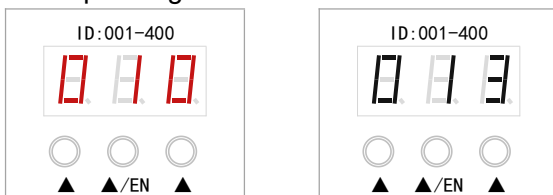

**Set the ID by LED Player. (Version only for 3.2.8 or above.)**

1. Click “Software” to open the software settings window.

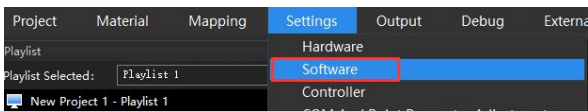

2. Click “Network” and set the first ID value. Click “Set” after select “Single link” or “Multi link”. Then the ID value of all controller will be setup.

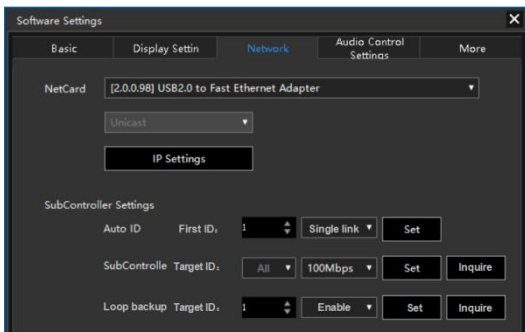

#### 4.2.4. CONFIGURE ADDRESSING

1. Long press “▲/EN” button and enter ID Setting. The lower right of each value of the digital tube flick “•”.

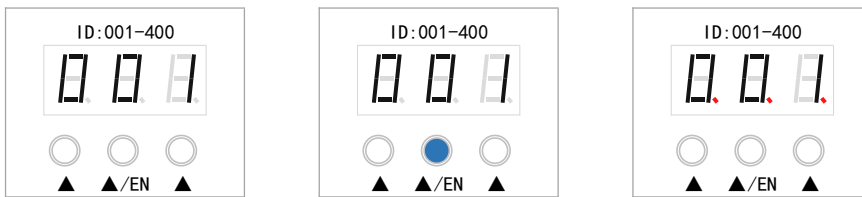

2. Long press “▲(left)” and “▲(right)” until the nixie tube shows “888”. And the lower right of each value of the digital tube flick “•”. It is start addressing.

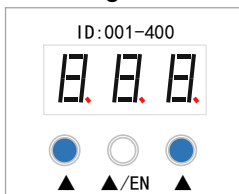

3. The “•” stops flashing when the address operation is completed.

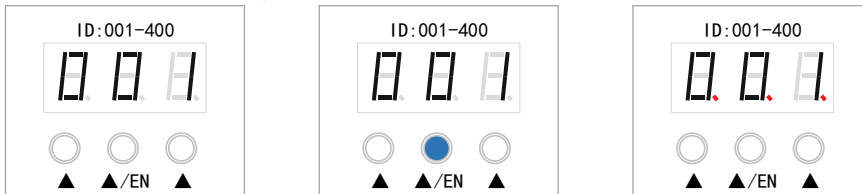

Note, the feature requires LED Player to send address parameters to the controller by the addressing function. Otherwise, E47 will be prompted.

Whether the light-fixture amp is successfully addressed actually depends on the display color of the light-fixture, refer to "UCCESSFULLY ADDRESSED AND SET PARAMETERS".

#### 5. IP ADDRESS SETTING (PC)

1. Open “Network Connection” on the PC, right click “Local Connection” and select “Properties”.

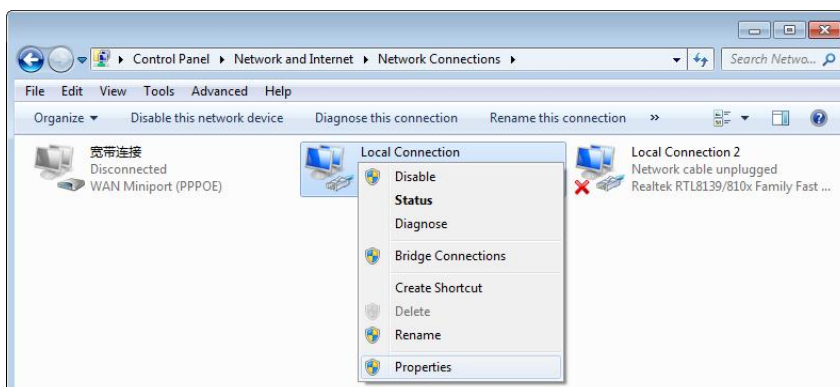

2. Select Internet Protocol (TCP/IP), then click “Properties”. Set the IP address as below.

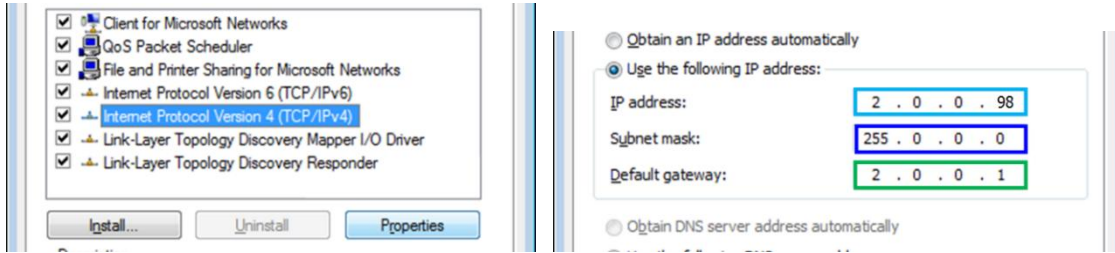

3. Click “OK” after the setting is finished.

## 6. ADDRESSING BY LED PLAYER

Access the controller correctly and open LED Player. Click Address of Debug to open the interface.

After setting the chip address drove by the controller, click "Address All Controllers" to save address data into controllers.

Note, If the controller is offline, there is a probability that the address data cannot be sent to the controller normally if it is offline.

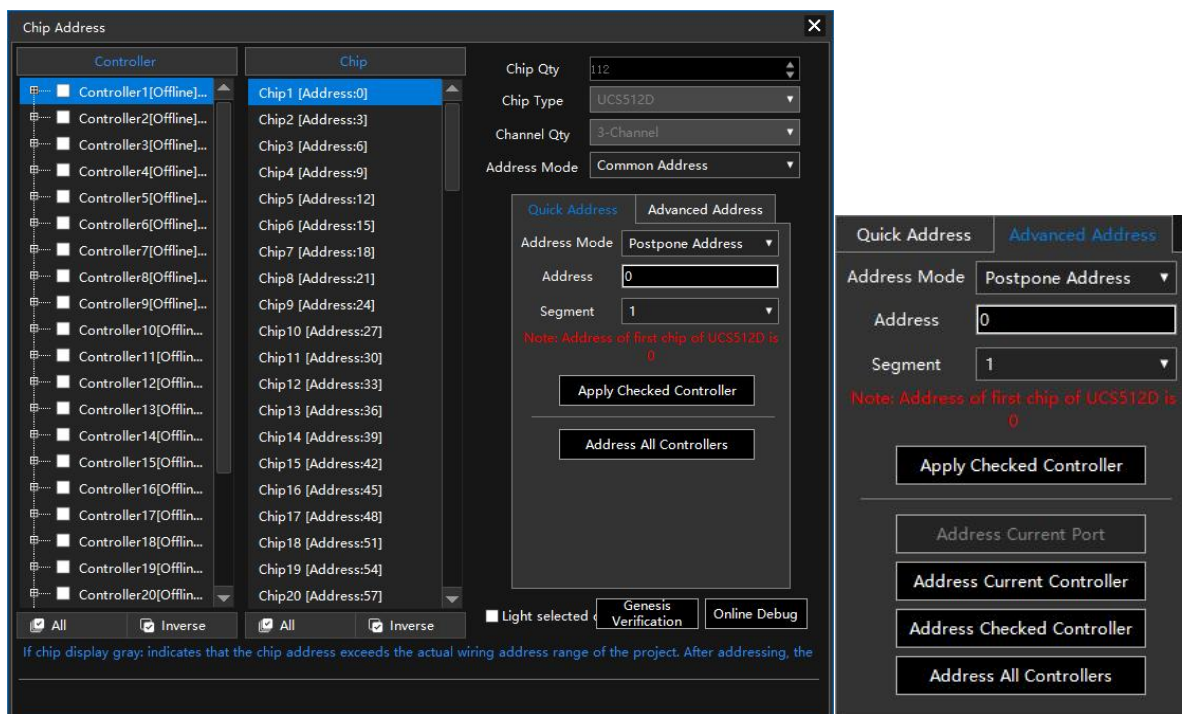

Hardware	Controller	Shows the number of controllers in the project. [Online] Indicates that the controller is connected properly. [Offline] Indicates that the controller will not be able to address the lighting fixtures. [Forbidden] Indicates that the driven chip is not DMX. It can be set at “Hardware” of “Settings”.
	Chip	Shows the number of chips and address information. Maximum 960 chips per port. If the chip address is beyond the actual wiring of project, the selected chip will not "light up".
	Online Debug	Click and jump into the One Debug interface.
Chip Address	Chip Qty.	The number of single drive points set by Hardware Settings.
	Chip Type	The chip set by Hardware Settings.
	Channel Qty.	The channel set by Hardware Settings.
	Address Mode	“Common Address” and “Auto-Increment”

	Address Mode	<p>“Un-select”, “Postpone Address”, “Use Same Address”.</p> <p>Un-select: When saving the current chip address parameter, the address of others will not change accordingly.</p> <p>Postpone Address: When saving the current chip address parameter, the subsequent will automatically change according to the original channel value.</p> <p>Use Same Address: When saving the current chip address parameter, all chips are set the same address.</p>
	Address	<p>Set the selected chip address. The chip list will be updated automatically after it is fill in the address.</p> <p>Note, Please do not fill in the value exceeding total chips to avoid abnormal output.</p>
	Segment	<p>Sets the number of pixels driven by the selected chip. The chip list is automatically updated after it be selected the number of segments.</p>
Address Application	Address All Controllers	<p>Send the address parameters to all controllers.</p>
	Advanced Address	<p>Apply Checked Controller: Click to save the address parameter of the checked controllers.</p> <p>Address Current Port: Click to address the lighting fixture of current port.</p> <p>Address Current Controller: Click to address the lighting fixture of current controllers.</p> <p>Address Checked Controller: Click to address the lighting fixture of the checked controllers.</p> <p>Address All Controllers: Click to address the lighting fixture of all controllers. It would be addressed correctly if the controller is offline.</p>
Light-up	<p>Check it and click the chip under a port. The chip will light up RGB (of RGBW). And the location of this chip can be seen in the LED Player preview area.</p> <p>Please ensure that the data of LED Player is consistent with the address of the actual lighting fixture. (It is recommended that the luminaire be addressed once before lighting up.)</p>	

## 7. APPENDIX (CHIPS ADDRESSING)

### 7.1. CHIP SUPPORT

Chip	Addressing	Custom Channel	Set parameters					
			No signal	Power-on	Current	Forward	Serial	GAMMA
UCS512A	√	×	×	×	×	×	×	×
UCS512B	√	×	×	×	×	×	×	×
UCS512C0	√	×	×	×	×	×	×	×
UCS512C1	√	×	√	√	√	×	×	×
UCS512C2	√	×	√	√	√	×	×	×
UCS512CBL	√	×	√	√	√	×	×	×
UCS512C4	√	×	×	√	×	×	×	×
UCS512CN	√	×	√	√	×	×	×	×
UCS512D	√	×	√	√	√	×	×	×
UCS512E0	√	√	√	√	√	√	×	×
UCS512EH	√	√	√	√	√	√	×	×
UCS512G4	√	×	√	√	√	×	×	√
UCS512G6	√	×	√	√	√	×	×	√

Chip	Addressing	Custom Channel	Set parameters					
			No signal	Power-on	Current	Forward	Serial	GAMMA
UCS512K series	√	√	√	√	√	√	×	√
UCS512H series	√	×	√	√	√	×	×	√
DMX512AP	√	×	×	×	×	×	×	×
SM16511	√	×	×	×	×	×	×	×
SM16512	√	×	×	×	×	×	×	×
SM16500	√	×	√	√	×	×	×	×
SM16520	√	×	×	×	×	×	×	×
SM16522P	√	×	×	×	×	×	×	×
SM16522PS	√	×	×	×	×	×	×	×
SM17500	√	√	√	√	√	×	×	×
SM17512	√	×	√	√	√	×	×	×
SM17520P	√	×	√	√	×	×	×	×
SM17522	√	×	√	√	√	×	×	×
SM18522P	√	×	√	√	√	×	×	√
SM18522PH	√	×	√	√	√	×	×	√
SW-D	√	×	×	×	×	×	×	×
Hi512A0	√	√	×	×	×	×	×	×
Hi512A4	√	×	√	√	×	×	×	×
Hi512A6	√	×	√	√	×	×	×	×
Hi512D	√	×	×	×	×	×	×	×
TM512AB3	√	×	×	×	×	×	×	×
TM512AL1	√	×	×	×	×	×	×	×
TM512ACx	√	×	×	×	×	×	×	×
TM512AD	√	×	√	√	√	×	×	×
QED512P	√	×	√	√	√	×	×	×
GS8512	√	×	×	×	×	×	√	√
GS8513	√	×	×	×	√	×	√	√
GS8515	√	×	×	×	√	×	√	√
GS8516	√	×	√	√	√	×	√	×
GS8516B	√	×	√	√	√	×	√	×
GS8523	√	×	√	√	√	×	√	×
GS8524	√	×	√	√	√	×	√	×
GS8525	√	×	√	√	√	×	√	×
GS8525T2	√	×	√	√	√	×	×	×
GS8526	√	×	√	√	√	×	√	×

## 7.2. SUCCESSFULLY ADDRESSED AND SET PARAMETERS

Chip	Lighting color after power on	Addressed		Byte + No signal + No signal		Current parameter		Self-Channel Setting	
		First chip	Other chip	First chip	Other chip	First chip	Other chip	First chip	Other chip
UCS512A	White	Blue	Blue	-	-	-	-	-	-
UCS512A1	White	Blue	Blue	-	-	-	-	-	-
UCS512A2	White	Blue	Blue	-	-	-	-	-	-
UCS512B3	White	Blue	Blue	-	-	-	-	-	-
UCS512C	Custom	White	White	-	-	-	-	-	-

Chip	Lighting color after power on	Addressed		Byte + No signal + No signal		Current parameter		Self-Channel Setting	
		First chip	Other chip	First chip	Other chip	First chip	Other chip	First chip	Other chip
UCS512C0	-	White	White	-	-	-	-	-	-
UCS512C1	-	Yellow	White	Power on	Power on	Yellow	White	-	-
UCS512C2	-	Yellow	White	Power on	Power on	Yellow	White	-	-
UCS512CBL	Blue	Yellow	White	Power on	Power on	White	White	-	-
UCS512C3	Custom	White	White	Red	Red	-	-	-	-
UCS512C4	Custom	White	White	Red	Red	-	-	-	-
UCS512CN	Custom	Yellow	White	Yellow	Power on	-	-	-	-
UCS512D	Custom	Yellow	White	Yellow	Power on	Yellow	Red	-	-
UCS512E0	Custom	Yellow	White	Yellow	Power on	-	-	Yellow	Green
UCS512EH	Custom	Yellow	White	Yellow	Power on	Yellow	Red	Yellow	Green
UCS512G4	Custom	Yellow	White	White (Custom)	White (Custom)	White	White	-	-
UCS512G6	Custom	Yellow (Custom)	White (Custom)	White (Custom)	White (Custom)	White	White	-	-
UCS512K series	Custom	Yellow	White	White	White	White	White	Yellow	White
UCS512H series	Custom	Yellow	White	White	White	White	White	-	-
DMX512AP	-	White	White	-	-	-	-	-	-
SM16512	-	Green	Green	-	-	-	-	-	-
SM16511	-	Green	Green	-	-	-	-	-	-
SM16500	Custom	Red	Green	Red	Power on	-	-	-	-
SM16520	-	Green	Green	-	-	-	-	-	-
SM16522P	Custom	Green	Green	-	-	-	-	-	-
SM16522PS	Custom	Green	Green	-	-	-	-	-	-
SM17500	Custom	Red	Green	Red	Power on	Red	Yellow	Red	Purple
SM17512	Custom	Red	Green	Blue	Blue	-	-	-	-
SM17520P	-	Red	Green	Red	Blue	Red	Yellow	-	-
SM17522	-	Red	Green	Red	Blue	Red	Yellow	-	-
SM18522P	-	Red	Green	Red	Blue	Red	Yellow	-	-
SM18522PH	-	Red	Green	Red	Blue	Red	Yellow	-	-
SW-D	-	Yellow	Green	-	-	-	-	-	-
Hi512A4	Custom	Red	Green	Red_	Green	-	-	-	-
Hi512A6	Custom	Red	Green	Red	Green	-	-	-	-
Hi512A0	-	White	White	White	White	-	-	-	-
Hi512D	-	Red	Green	Green	Green	Green	Green	-	-
Hi512E	-	Red	Green	Green	Green	Green	Green	-	-
TM512AB3	White	Blue	Blue	-	-	-	-	-	-
TM512AL1	White	Blue	Blue	-	-	-	-	-	-
TM512AC0	-	White	White	-	-	-	-	-	-
TM512AC2	Custom	White	White	-	-	-	-	-	-
TM512AC3	Blue	White	White	-	-	-	-	-	-
TM512AC4	Blue	White	White	-	-	-	-	-	-

Chip	Lighting color after power on	Addressed		Byte + No signal + No signal		Current parameter		Self-Channel Setting	
		First chip	Other chip	First chip	Other chip	First chip	Other chip	First chip	Other chip
TM512AD	Blue	Yellow	White	Yellow	Power on	Yellow	Red	-	-
GS8512	Custom	Red	Cyan	-	-	-	-	-	-
GS8513	Red+Cyan	Red	Cyan	-	-	-	-	-	-
GS8515	Red+Cyan	Red	Cyan	-	-	-	-	-	-
GS8523	-	Red	Cyan	-	-	-	-	-	-
GS8516	-	Red	Cyan	-	-	-	-	-	-
GS8516B	-	Red	Cyan	Blue	Blue	Blue	Blue	-	-
GS8524	-	Red	Cyan	-	-	-	-	-	-
GS8525	-	Red	Cyan	-	-	-	-	-	-
GS8525T2	-	Red	Cyan	-	-	-	-	-	-
GS8526	-	-	-	-	-	-	-	-	-

## 8. ART-NET SETTINGS ON SOFTWARE

### 8.1. OBTAINING CONTROLLER INFORMATION

1. Select the network adapter for connecting to the controller. (Set the static IP address of the network adapter that does not conflict with the controller in advance.)
2. Click "Refresh" to obtain the controllers' information.

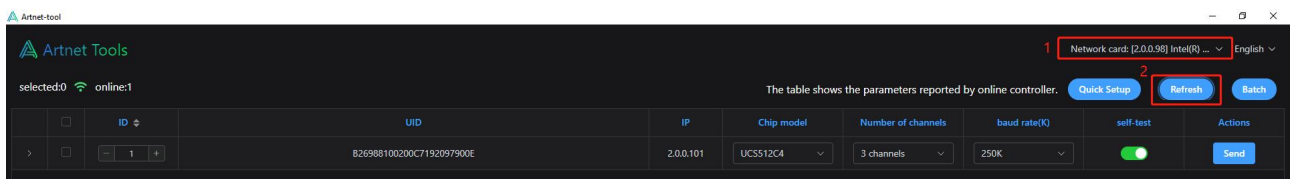

### 8.2. SET BASIC PARAMETERS OF THE CONTROLLER

1. Select the controllers which we want to set after the controllers are correctly connected and read.
2. Click "Send" to update after setting IP address, chip type, baud rate, channel.

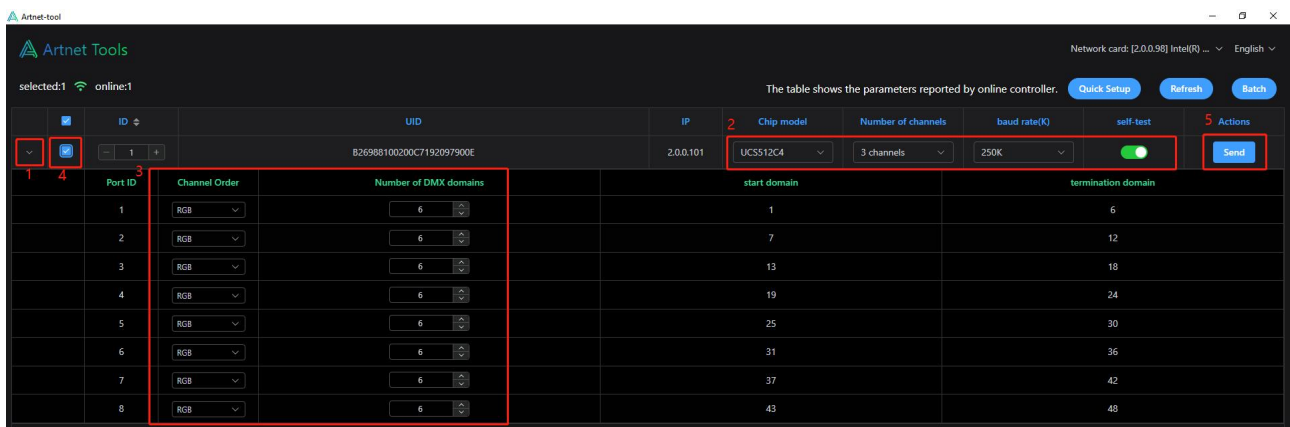

We can click "Quick Setup" to set the same parameter to multiple selected controllers.

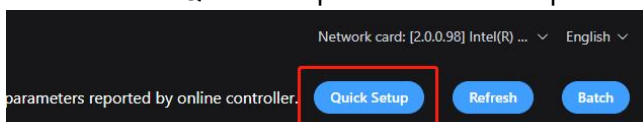

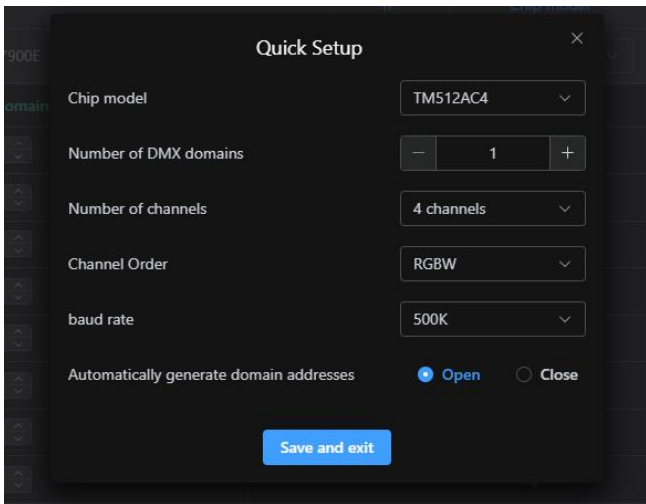

## 9. ERROR CODE AND TROUBLE SHOOTING

Display		Measure
E08	UID does not match	Use the corresponding code to play.
E09	UID in player does not match the one in controller.	The controller is bound with a specific engineering code. Use the corresponding code to play.
E11	The UID of controller does not match the LED player.	<p>The engineering code of the controller is inconsistent with that of the project. The solution is as follows:</p> <ol style="list-style-type: none"> <li>1. The controller is bound with a specific engineering code. Use the corresponding code to play.</li> <li>2. The controller is not bound to a engineering code. Use a general project to play.</li> </ol>
E40	Failed to write the parameters into the flash primary area.	The controller hardware is damaged. Contact us please.
E41	Failed to write the parameters into the flash spare area.	The controller hardware is damaged. Contact us please.
E42	Failed to read the parameters into the flash primary area.	The controller hardware is damaged. Contact us please.
E43	Failed to read the parameters into the flash spare area.	The controller hardware is damaged. Contact us please.
E44	The network of the controller is unavailable.	<p>There is no output of the controller or the next one:</p> <ol style="list-style-type: none"> <li>1. Ensure all ports of the controller is correctly connected.</li> <li>2. Ensure the controller is good contact with the network cable.</li> <li>3. Ensure the sequence of the cable is T568B.</li> <li>4. Switch to a normal controller and check whether the network cable is faulty.</li> <li>5. Ensure that the length of the network cable does not exceed 100 m. Or replace the network cable with a better one .</li> <li>6. After the above has been excluded, the controller hardware is damaged. Contact us please.</li> </ol>
E45	No program is written to the main board or the program is	<ol style="list-style-type: none"> <li>1. Wait until the controller upgrade is complete.</li> <li>2. If no program upgrade is performed, the program may be removed</li> </ol>

Display		Measure
	lost.	unexpectedly. Contact us please. 3. If the program is not upgraded and the program cannot be burned online, the hardware is damaged. Contact us please.
E46	Auto addressing is timed out.	1. Ensure the controller's wiring is correct. 2. Ensure the number of controllers in a link to less than 30. 3. Ensure all controllers are powered on. Wait 10 seconds and try again. 4. Ensure the faulty machines exist on the network.
E47	Without the configure addressing data.	Please use software to address first.
- - -		Power off the controller and check that the internal cable connections are normal.
None		Ensure that the power supply is properly connected and supplied. The controller hardware is damaged. Contact us please.
None	If the controller keeps switching on/off while the LED Player is working properly, it may cause data congestion.	In this case, we can directly plug and remove the network cable from the IPC, or restart the output network adapter on the IPC.

To restart the NIC follows.

1. Right click "This PC" to select "Manage".

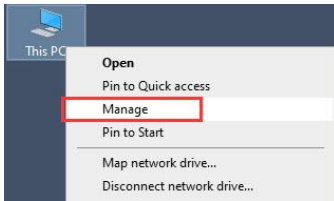

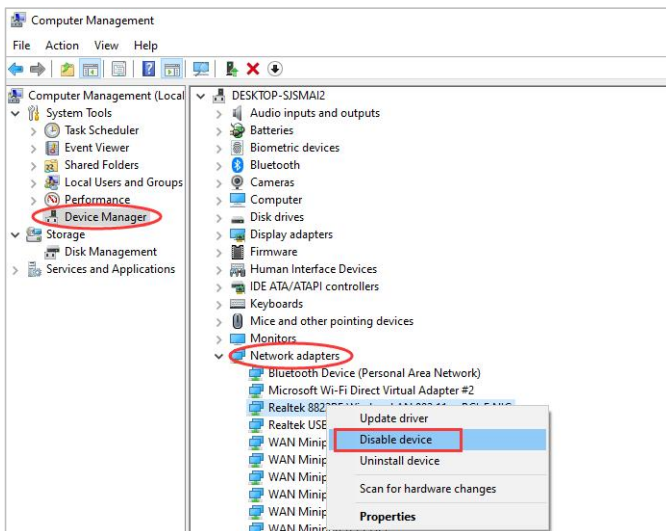

2. Click "Network adapters" of "Device Manager", and right click the NIC which output control luminaires to select "Disable device".

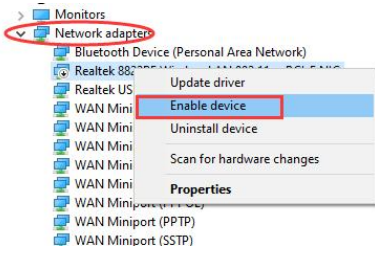

3. Right click the NIC again and select “Enable device”.



## 10. PARTS LIST

Picture	Model	Number	Remark
	Power cord	1	
	5P Female terminal stud	8	
	Cat 5e (T568B)	1	