

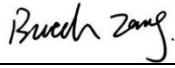

<b>TEST REPORT VDE-AR-N 4105 Power generation systems connected to the low-voltage distribution network</b>	
<b>Report Reference No.:</b>	2401B1675SHA -001
<b>Tested by (name + signature):</b>	Butch Zang 
<b>Approved by (name + signature):</b>	Kevin Zhu 
<b>Date of issue :</b>	2024-03-06
<b>Contents:</b>	26 pages
<b>Testing Laboratory:</b>	<b>Intertek Testing Services Shanghai.</b>
<b>Address:</b>	Building No.86, 1198 Qinzhou Road (North), Shanghai 200233, China.
<b>Testing location / procedure:</b>	<b>TL</b> <input checked="" type="checkbox"/> <b>SMT</b> <input type="checkbox"/> <b>TMP</b> <input type="checkbox"/>
<b>Testing location / address:</b>	Same as above
<b>Applicant's name :</b>	Shenzhen Lvyou Energy Technology Co., Ltd
<b>Address:</b>	103-104, Building 12, Dawangshan 2nd Industrial Zone, Shajing, Baoan District, Shenzhen, Guangdong, China
<b>Test specification:</b>	
<b>Standard :</b>	VDE-AR-N 4105:2018 conjunction with DIN VDE V 0124-100:2020
<b>Test procedure:</b>	Type Test
<b>Non-standard test method:</b>	N/A
<b>Test Report Form/blank test report</b>	
<b>Test Report Form No. :</b>	VDE_4105_TTRF_V1.0
<b>TRF Originator :</b>	Intertek Shanghai
<b>Master TRF :</b>	2020-06
This publication may be reproduced in whole or in part for non-commercial purpose as long as Intertek is acknowledged as copyright owner and source of the material. Intertek takes no responsibility and will not assume liability for damages resulting from the reader's interpretation of the reproduced material due to its placement and context.	

This report is for the exclusive use of Intertek's Client and is provided pursuant to the agreement between Intertek and its Client. Intertek's responsibility and liability are limited to the terms and conditions of the agreement. Intertek assumes no liability to any party, other than to the Client in accordance with the agreement, for any loss, expense or damage occasioned by the use of this report. Only the Client is authorized to permit copying or distribution of this report and then only in its entirety. Any use of the Intertek name or one of its marks for the sale or advertisement of the tested material, product or service must first be approved in writing by Intertek. The observations and test results in this report are relevant only to the sample tested. This report by itself does not imply that the material, product, or service is or has ever been under an Intertek certification program.

Test item description:	Micro Grid-tied Inverter
Trade Mark:	N/A
Manufacturer:	Same as applicant
Model/Type reference:	ES-800
Rating:	See below Specifications table

Specifications table	
Model	ES-800
Input:	
Vmax PV (Vdc)	55
Isc PV (absolute Max.) (A)	24
Number MPPT trackers	2
Number input strings	2
Max. PV input current(A)	14*2
MPPT voltage range (Vdc)	16 to 55
Output	
Normal Voltage(V)	<input checked="" type="checkbox"/> 1/N/PE 230Vac <input type="checkbox"/> 3 $\phi$ /N/PE 230/400Vac
Frequency (Hz)	<input checked="" type="checkbox"/> 50 Hz <input type="checkbox"/> 60Hz
Current (Max. continuous) (A)	3.13
Power rating (W)	720
Power Rating (VA)	720
Power factor /rated	$\geq 0.99$
others	
Protective class	Class I
Ingress protection (IP)	IP 67
Temperature (°C)	-40°C to +65°C
Inverter Isolation	<input type="checkbox"/> Non-isolated <input checked="" type="checkbox"/> High frequency isolated
Overtoltage category	OVC III (AC Main), OVC II (PV)
Weight (kg)	1.8
Dimensions (WxHxD) (cm)	22.3 x 4.3 x 23

<b>Test item particulars</b>	
PGU connect to Grid System	<input checked="" type="checkbox"/> 1/N/PE <input type="checkbox"/> 3/PE <input type="checkbox"/> 3/N/PE
PGS( kVA)	<input checked="" type="checkbox"/> ≤3.68 <input type="checkbox"/> ≤13.8 <input type="checkbox"/> >13.8
Default cos φ- reactive power adjusted	<input checked="" type="checkbox"/> a fixed displacement factor, cos φ=1 <input type="checkbox"/> Standard characteristic curve for cos φ (P) <input type="checkbox"/> non-Standard characteristic curve for cos φ (P)
Function of cos φ/Q- reactive power adjusted	<input checked="" type="checkbox"/> Not adjusted <input type="checkbox"/> a fixed displacement factor cos φ. <input type="checkbox"/> Characteristic curve for cos φ (P) <input type="checkbox"/> Characteristic curve for Q(U) <input type="checkbox"/> Dynamic network supporting (FVRT)
Function of active power adjusted	<input checked="" type="checkbox"/> Active power reduction <input type="checkbox"/> Active power output by over-frequency <input type="checkbox"/> Active power output by under-frequency <input type="checkbox"/> P <sub>AV,E</sub> monitoring
NS protection	<input type="checkbox"/> Central NS protection <input checked="" type="checkbox"/> Integrated NS protection
Voltage –Line to line	<input type="checkbox"/> Arithmetically from the three line-to-neutral voltages <input checked="" type="checkbox"/> Measured separately. <input checked="" type="checkbox"/> N/A
IP protection class :	IP65
Remark PGS: Power Generation System, PGU: Power Generation unit.	
<b>Possible test case verdicts:</b>	
- test case does not apply to the test object:	N/A
- test object does meet the requirement:	P(Pass)
- test object does not meet the requirement:	F(Fail)
Testing:	
Date of receipt of test item :	2023-09-26
Date (s) of performance of tests :	2023-09-27 to 2023-12-28
<b>General remarks:</b>	
<p>The test results presented in this report relate only to the object (single PV inverter unit) tested. The testing voltage is 230Vac single phase. The information about Generating Plant is not considered and tested.</p> <p>Installer and relevant persons shall comply with VDE-AR-N4105 and relevant standard and Grid Code in this standard.</p> <p>This report shall not be reproduced, except in full, without the written approval of the Issuing testing laboratory.</p> <p>"(see Enclosure #)" refers to additional information appended to the report.</p> <p>"(see appended table)" refers to a table appended to the report.</p> <p>Throughout this report a point is used as the decimal separator.</p> <p>Determination of the test result includes consideration of measurement uncertainty from the test equipment and methods.</p> <p>Determination of the test conclusion is based on IEC Guide 115 in consideration of measurement uncertainty.</p> <p>The test results presented in this report relate only to the item tested. See general product information next for details information.</p> <p>The test does not include the faults inside the CPU and software evaluation as agreed with client. All the tests are performed on a single unit.</p> <p>The clause number in first is about VDE-AR-N 4105 The clause number in bracket is about DIN V VDE V 0124-100</p>	

**General product information:**

1. The Hybrid inverter is isolated (transformer) inverter which works convert PV to the grid and load, it intends to be connected into household generation systems and utilizes solar power, utility power and battery power to ensure continuous power supply.
2. In order to protect the inverter, user and installer, external DC and AC circuit breaker shall be equipped for all source port (battery, AC grid) at the end-use application.
3. If certain functions are not permitted by local regulation, the function shall be disabled by hardware or software setting (if applicable) by the manufacturer before putting into the market. For example, it's not permissible to draw electricity from the grid and then feed it back in order to claim statutory reimbursement in some nations.
4. Low voltage electrical installations shall comply with national and local regulations. Only qualified electricians are allowed to install and maintain the converter.

Block diagram:

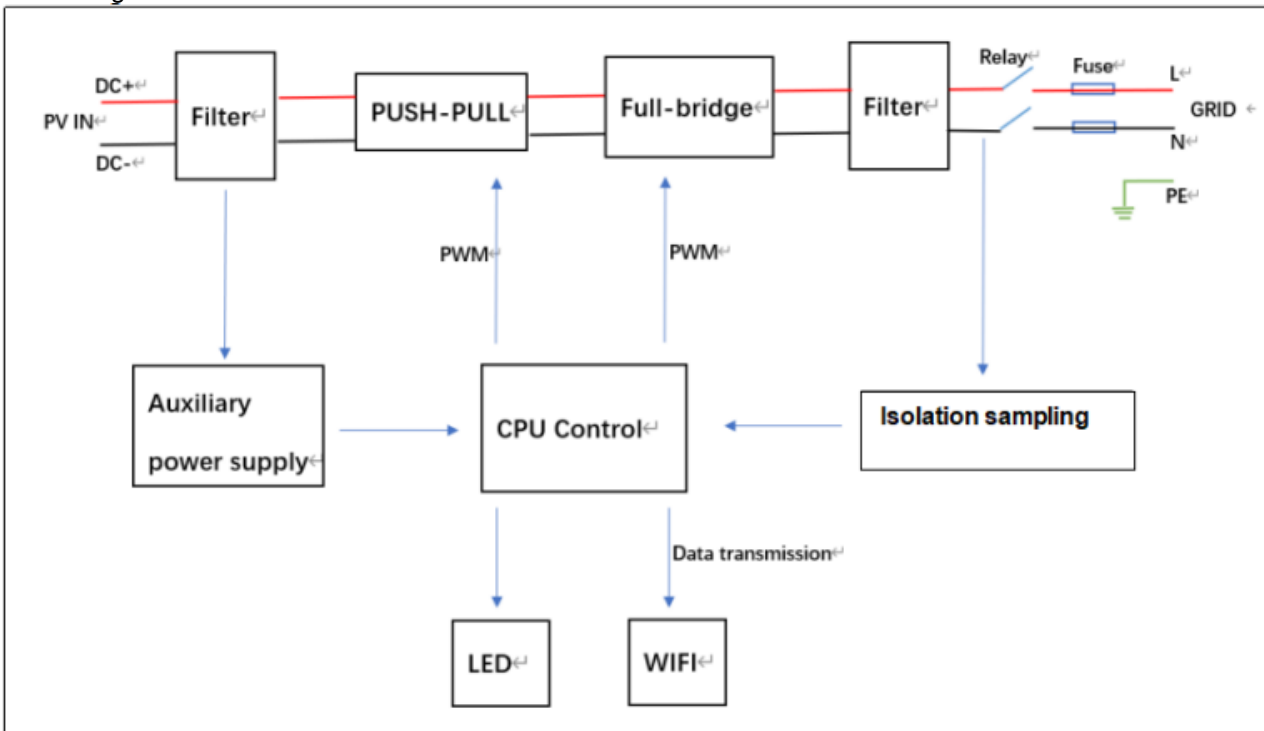

Version Number:

Software versioning: KS-01

Hardware version number: 0900302

**Abbreviations used in the report:**

PGU: Power Generation unit.

PGS: Power Generation System

In: Rated current of power generation unit.

Copy of marking plate:

## PV Microinverter

Model	ES-800
Max. Input Voltage (DC)	55V
PV Operating Voltage (DC)	18V-55V
Max. Continuous Input Current (DC)	2 x 14A
Nominal Output Voltage (AC)	230V
Max. Continuous Output Current (AC)	3.47A
Max. Continuous Output Power	800W
Nominal Output Frequency	50Hz
Peak Efficiency	92%
Type of Enclosure	IP67
Protective Class	Class I
Operating Ambient Temp.	-40°C~+65°C



VDE-AR-N 4105			
Clause	Requirement - Test	Result - Remark	Verdict
4	General framework conditions		--
4.1	Provisions and regulations	NA for PGU testing	N/A
4.2	Application procedure and connection relevant documents	NA for PGU testing	N/A
4.3	Initial start-up of the power generation system	NA for PGU testing	N/A
5	Network connection		--
5.1	Principles for determination of the network connection point	NA for PGU testing	N/A
5.2	Rating of the network equipment	NA for PGU testing	N/A
5.3	Permissible voltage change	NA for PGU testing	N/A
5.4	Network interactions		N/A
5.5	Connection criteria		--
5.5.1	General		P
	When connecting a power generation system or a storage unit, the technical connection conditions of the network operator shall be observed.	Shall be considered full feed-in that in accordance with VDE-AR-N 4100 in the power system	P
5.5.2	PAV, E monitoring (feed-in limitation)	The independent equipment shall be installed at end use.	N/A
5.5.3	Power generation systems ready for connection		N/A
5.6	Three-phase inverter systems	No Three-phase inverter system will be combined.	N/A
5.7	Behaviour of the power generation system at the network		P
5.7.1	General		P
	For frequencies between 47,5 Hz and 51,5 Hz, automatic disconnection from the network due to a frequency deviation is not permitted. The actual operating principle and the associated exceptions are detailed in 5.7.4.3. Frequency-dependent active power control is implemented in the open-loop control of the power generation units.		P
5.7.2	Steady-state voltage stability/reactive power supply	No such function, the independent equipment shall be installed at end use.	N/A
5.7.2.1	General boundary conditions		N/A
5.7.2.2	Reactive power supply at $\Sigma SE_{max}$		N/A
5.7.2.2.1	General		N/A
	It is permissible in certain cases described in 5.7.2.2.2 and 5.7.3 to reduce the active power supply to the benefit of the reactive power supply. This is not considered a reduction of the active power supply in the context of network security management. Power generation systems shall comply with the reactive power supply irrespective of the number of feed-inphases under normal operating conditions in the voltage tolerance band $U_n \pm 10\%$ .		N/A
5.7.2.2.2	Type 2 systems – inverters only		N/A
5.7.2.2.3	Type 2 systems – Asynchronous generators (directly connected to the network and principally not able to control any reactive power)	Inverter only	N/A
5.7.2.2.4	Type 1 systems and type 2 systems – stirling generators and fuel cells	Inverter only	N/A

VDE-AR-N 4105			
Clause	Requirement - Test	Result - Remark	Verdict
5.7.2.3	Reactive power supply smaller than P <sub>E</sub> max	No such function, the independent equipment shall be installed at end use.	N/A
5.7.2.4	Methods for reactive power supply	No such function, the independent equipment shall be installed at end use.	N/A
	a) reactive power voltage characteristic curve Q(U); or		N/A
	b) displacement factor/active power characteristic curve cos φ (P); or		N/A
	c) fixed displacement factor cos φ.		N/A
	The Q(U) rule applies only to three-phase power generation units connected to the three-phase current system.		N/A
5.7.2.5	Requirements for reactive power methods of type 2 systems (inverters only) and type 1 systems	No such function, the independent equipment shall be installed at end use.	N/A
	In the delivery state, none of the three reactive power methods specified in 5.7.2.4 is set as default. During the commissioning of power generation units, the method specified by the network operator shall be set by the system installer. Without the setting of the method specified by the network operator, power generation units shall not feed in any power.		N/A
5.7.2.6	Special aspects regarding the extension of power generation systems	No such function, the independent equipment shall be installed at end use.	N/A
5.7.3	Dynamic network stability	No such function, the independent equipment shall be installed at end use.	N/A
5.7.3.1	General		N/A
5.7.3.2	Dynamic network stability for type 1 units Transient stability – Reaction to network faults		N/A
5.7.3.3	Dynamic network stability for type 2 units and storage units	No such function, the independent equipment shall be installed at end use.	N/A
	The following conditions apply to all type 2 power generation units and storage units: As long as the line-neutral-voltages at the generator terminals of the power generation unit or storage unit do not exceed the limit curves shown in Figure 12 (red for the under-voltage limit curve, blue for the over-voltage limit curve), both the power generation unit and the storage unit shall neither become unstable nor disconnect from the network throughout the operating range.		N/A

VDE-AR-N 4105			
Clause	Requirement - Test	Result - Remark	Verdict
	For evaluating the curves, the smallest respective value of the line-neutral-voltages at the power generation unit or the storage unit shall be used in case of a voltage drop, and the highest respective value of the line-neutral- voltages at the power generation unit or the storage unit shall be used in case of a voltage rise. As far as the set values for the NS protection given in Table 2 (column "Inverter(s)") anticipate the requirements given in Figure 12 in certain working points, merely the checking of the set values for NS protection is required for the verification procedure.		N/A
	If the voltage at the generator terminals falls below $< 0,8 U_n$ or exceeds $> 1,15 U_n$ (onset of fault), type 2 power generation units and storage units shall ride through voltage drops without feeding current into the network of the network operator (limited dynamic network stability).		N/A
	This requirement is deemed to be met, if the current fed in by the power generation unit(s) and/or the storage unit in any line conductor does not exceed 20 % of the rated current $I_r$ within 60 ms and 10 % of $I_r$ within 100 ms upon a voltage drop below $0,8 U_n$ or a voltage rise above $1,15 U_n$ .		N/A
	Behaviour after the end of a fault. If, after the end of a fault, the network voltage resumes a value within the voltage band from $-15 \% U_n$ to $+10 \% U_n$ and the active current of the power generation unit and/or the storage unit has been reduced during the network fault, it shall, immediately after the end of the fault, be increased to its pre-fault value as quickly as possible. The transient period shall not exceed a maximum of 1 s. The reactive power supply follows 5.7.2.5 in its time-related behaviour. In case of rotating machinery, the transient period shall not exceed a maximum of 6 s. At voltages of $1,15 U_n$ , the power generation units and storage units shall not disconnect from the network for a period of up to 60 s after the onset of the fault. If the tripping of the self-protection of the power generation units and/or the storage unit is imminent, these units can adjust their reactive power behaviour such as to prevent self-protection tripping.		N/A
5.7.4	Active power output		P
5.7.4.1	General		P
	In cases where set-points are specified by a third party (e. g. direct marketing) and of network security management in accordance with 5.7.4.2, the new set-point shall be approached with the customer installation's power gradients listed below in relation to the network connection point. Implementation of those power gradients directly at the power generation units or storage units is sufficient for meeting the requirement.	The active power can be remote-controlled on the communication interface	P
5.7.4.2	Network security management		P
5.7.4.2.1	Types of power generation systems and storage units	The active power can be remotely controlled on the communication interface	P

VDE-AR-N 4105			
Clause	Requirement - Test	Result - Remark	Verdict
	Photovoltaic systems		P
	Cogeneration of power and heat (CHP) systems, wind, biogas, hydroelectric power as well as landfill and sewage gas systems		N/A
	Storage units buffering EEG or KWKG systems		N/A
	Any EEG and KWKG systems with an intelligent measurement system		N/A
	Any power generation systems and storage units other than those indicated above		N/A
5.7.4.2.2	Implementation of network security management	No such function, the independent equipment shall be installed at end use.	N/A
5.7.4.2.3	Active power adjustment at over-frequency and under-frequency	No such function, the independent equipment shall be installed at end use.	N/A
5.7.4.4	Voltage-dependent active power reduction	No such function, the independent equipment shall be installed at end use.	N/A
5.7.5	<p>Short-circuit contribution</p> <p>Due to the operation of a power generation system, the short-circuit current of the low-voltage network is increased by the short-circuit current of the power generation system. Therefore, the short-circuit current of the power generation system to be expected at the network connection point shall be indicated in accordance with 4.2. For the determination of the initial short-circuit AC current contribution I<sub>kA</sub> of a power generation system, the following roughly estimated values can be assumed:</p> <ul style="list-style-type: none"> <li>– for synchronous generators: 8 times the rated current;</li> <li>– for asynchronous generators: 6 times the rated current;</li> <li>– for generators and storage units with inverters: the rated current.</li> </ul> <p>If the power generation system causes a short-circuit current increase in the network operator's network in excess of the rated value, then connection owner and network operator shall agree upon appropriate measures limiting the short-circuit current from the power generation system accordingly.</p>		P
6	Construction of the power generation system/network and system protection (NS protection)		--
6.1	General requirements		N/A
	<p>The network and system protection (NS protection) is a type-tested protective device with a NS protection certificate (see Form E.6) wherein all protective functions specified in 6.5 are installed. The NS protection acts on the interface switch in accordance with 6.4.</p> <p>Depending on the sum of the maximum apparent powers of all power generation systems and storage units connected to the same network connection point <math>\Sigma S_{Amax}</math>, the following conditions apply to the NS protection:</p>		P
6.2	Central NS protection		N/A
6.3	Integrated NS protection	integrated NS protection	P
6.4	Interface switch		P
6.4.1	General		P

VDE-AR-N 4105			
Clause	Requirement - Test	Result - Remark	Verdict
	For the connection of the power generation system to the network operator's low-voltage network or to the remaining customer installation, an interface switch shall be used. The interface switch is controlled by the NS protection and automatically triggers if at least one protective function responds.		P
	The functional check of the interface switch shall be carried out according to a) or b) or c): a) by using an interface switch which, in its active state, requires a control voltage to be applied continuously and which disconnects automatically when this voltage is no longer applied. The operational connection and disconnection processes shall be monitored; b) by connection and disconnection of the interface switch via the NS protection and monitoring its proper functioning (e. g. break contact of a monitoring contact) at least once daily; c) by using the integrated interface switch and the integrated NS protection for PV and battery inverters in compliance		P
6.4.2	Central interface switch		N/A
6.4.3	Integrated interface switch		N/A
	In the case of integrated NS protection, the NS protection can be integrated in the programmable system control of the power generation units (e.g. in the inverter control). If so, then both the test button and the sealing may be omitted, however, password protection is required, if the protective function U > is adjustable. The integrated NS protection acts on an integrated interface switch (see 6.4.3).		N/A
6.5	Protective devices and protection settings		P
6.5.1	General		P
	The purpose of NS protection is to disconnect the power generation system from the network in the event of inadmissible voltage and frequency values (also refer to DIN VDE 0100-551 (VDE 0100-551)). This is meant to prevent inadvertent feed-in from the power generation system into a partial network separated from the main distribution network.		P
6.5.2	Protective functions		P
	The NS protection shall be provided with a means for preventing unauthorised access (z. B. sealable, password protection). The rise-in-voltage protection U > shall be designed such as to be adjustable in the NS protection (see Table 2, Footnote b). Additionally, the time delay of the voltage drop protection U < and U << for directly coupled synchronous and asynchronous generators with Pn > 50 kW shall also be designed such as to be adjustable in the NS protection (see Table 2, Footnote d). Any other protective functions listed in 6.5.1 are either to be installed permanently, i. e. not adjustable, in the NS protection or to be provided with an additional separate protection against unauthorised access (e. g. password protection) for preventing modifications.		P
6.5.3	Islanding detection	(See appended table)	P
6.6	Further requirements for power generation systems	Shall be considered in PGS	NA
7	Metering for billing purposes		NA
8	Operation of the system		P

VDE-AR-N 4105			
Clause	Requirement - Test	Result - Remark	Verdict
8.1	General		P
8.2	Special aspects of the management of the network operator's network		NA
8.3	Connection conditions and synchronisation		P
8.3.1	General		P
	<p>Power generation systems and storage units shall be connected to the network operator's network only if a suitable device determines that both the mains voltage and the mains frequency are within the tolerance range of 85 % Un to 110 % Un or 47,5 Hz to 50,1 Hz, respectively, for a period of at least 60 seconds.</p> <p>Additionally, the delay times for the reconnection of a generator and the staggered times applicable when connecting several generators shall be sufficient for safely finishing any control and adjustment processes within the power generation system and/or the storage unit caused by the connection.</p> <p>In case of power generation systems and storage units being reconnected to the network operator's network at the tripping of the NS protective device or the PAV, E monitoring, the active power of controllable power generation systems and storage units supplied to the network operator's network shall not exceed the gradient of 10 % of the active power P<sub>Amax</sub> per minute. Non-controllable power generation systems and storage units can connect after 1 min to 10 min (random generator) or later.</p>	(See appended table)	P
8.3.2	Connection of synchronous generators		N/A
8.3.3	Connection of asynchronous generators		N/A
8.3.4	<p>Connection of power generation units and storage units with inverters</p> <p>Power generation units with inverters (such as photovoltaic systems) and storage units with inverters shall only be connected with <math>k_{max} \leq 1,2</math>.</p>		P
8.4	Special aspects regarding the planning, installation and operation of power generation systems and storage units each with P <sub>Amax</sub> ≥ 135 kW		NA
9	Verification of electrical properties		P
	Annex A: Explanations (informative)		---
	Annex B: Connection examples and measurement strategies (informative)		---
	Annex C: Examples of meter panel configurations (informative)		---
	Annex D: Examples for the connection evaluation of power generation systems -Connection of a 20 kW PV system (informative)		---

DIN VDE V 0124-100			
Clause	Requirement - Test	Result - Remark	Verdict
5.2.2	Rapid voltage change (Kimax)		P
5.2.3	Flicker		P
5.2.4	Harmonics and Inter-harmonics (I inter, I higher)		P
5.2.5	Commutation notches		N/A
5.2.6	DC current feeding to network (Idc)		P
5.3.2	Tests of three-phase inverter (Imbalance)		N/A
5.3.3	Symmetry operation with a symmetry device		N/A
5.4.2	Measurement of active- and reactive power ranges (P&Q range)		N/A
5.4.3	Active power reduction through setting provision (P control)		P
5.4.4	Active power output of PGU by over-frequency (LFSM-O)		N/A
5.4.5	Active power output of ESS by over-frequency (LFSM-O)		N/A
5.4.6	Active power output of PGU by under-frequency (LFSM-U)		N/A
5.4.7	Active power output of ESS by under-frequency (LFSM-U)		N/A
5.4.8.2	Tests of reactive power / displacement factor setting accuracy (Fixed $\cos\phi$ )		N/A
5.4.8.3	Tests of displacement factor- / active power character curve ( $\cos\phi$ (P))		N/A
5.4.8.4	Tests of reactive power-voltage character curve (Q(U))		N/A
5.5.2	NS-protection		N/A
5.5.3	Central NS-protecton		N/A
5.5.4	Integrated NS-protection		N/A
5.5.6	Interface switch (Functional safety)		P
5.5.7	Protection devices and protection settings (OV/UV, OF/UF)		P
5.5.9	Constructional features of NS protection		P
5.5.10	Islanding detection		P
5.6	Connection conditions and synchronization (Reconnection)		P
5.7	Verification of $P_{AV,E}$ monitoring		N/A
5.8	Verification of dynamic network supporting (FVRT)		N/A

Appendix table1

8.3.4 (5.2.2)	TABLE: Rapid voltage change (Kimax)			P
Test Conditions	Measurements			Limit
	U/Un	I/In	Ki	Ki
Starting to 50%Pn	1.00	0.36	0.12	≤ 1.2
Starting to 100% Pn	1.00	3.14	1.00	≤ 1.2
Stopping at 100% Pn	1.00	3.08	0.98	≤ 1.2
Note(s):				

(5.2.3)	TABLE: Flicker				P
Measurement	Plt	0.11			
	Limit	0.65			
	Pst	dc[%]	dmax[%]	d(t)[ms]	
	1.0	3.3	4.0	500	
1	0.084	0.096	0.178	0.0	
2	0.120	0.127	0.280	0.0	
3	0.129	0.187	0.260	0.0	
4	0.136	0.151	0.399	0.0	
5	0.080	0.136	0.170	0.0	
6	0.080	0.111	0.172	0.0	
7	0.080	0.108	0.180	0.0	
8	0.081	0.098	0.148	0.0	
9	0.082	0.109	0.164	0.0	
10	0.130	0.159	0.350	0.0	
11	0.125	0.082	0.245	0.0	
12	0.129	0.104	0.222	0.0	
Note(s): PGU and ESS with nominal current ≤75A (Per DIN EN 61000-3-3)					

(5.2.4)		TABLE: Harmonics										P
Harmonics												
P/P <sub>n</sub> [%]	0	10	20	30	40	50	60	70	80	90	100	Limit
Order No.	I/In [%]											
2	0.73	0.37	0.35	0.34	0.36	0.37	0.38	0.34	0.41	0.44	0.56	--
3	0.58	0.98	0.36	0.29	0.23	0.21	0.17	0.22	0.19	0.21	0.30	--
4	0.47	0.21	0.19	0.21	0.16	0.15	0.16	0.13	0.12	0.17	0.27	--
5	0.56	1.16	0.69	0.59	0.53	0.51	0.44	0.34	0.32	0.39	0.50	--
6	0.56	0.18	0.03	0.05	0.07	0.07	0.08	0.09	0.09	0.03	0.07	--
7	0.53	0.74	0.56	0.44	0.39	0.38	0.42	0.40	0.36	0.28	0.18	--
8	0.60	0.09	0.03	0.05	0.04	0.02	0.01	0.01	0.04	0.05	0.08	--
9	0.58	0.05	0.40	0.36	0.33	0.28	0.25	0.25	0.25	0.21	0.05	--
10	0.47	0.10	0.09	0.06	0.06	0.03	0.03	0.03	0.22	0.03	0.06	--
11	0.51	0.12	0.25	0.23	0.21	0.20	0.20	0.20	0.17	0.14	0.05	--
12	0.51	0.11	0.04	0.02	0.03	0.03	0.02	0.04	0.29	0.04	0.04	--
13	0.49	0.14	0.03	0.09	0.11	0.10	0.07	0.08	0.08	0.05	0.03	--
14	0.49	0.08	0.06	0.07	0.05	0.02	0.01	0.01	0.02	0.04	0.04	--
15	0.47	0.20	0.02	0.05	0.05	0.07	0.08	0.06	0.05	0.02	0.03	--
16	0.40	0.07	0.06	0.03	0.02	0.02	0.03	0.03	0.01	0.03	0.04	--
17	0.38	0.07	0.09	0.04	0.02	0.01	0.02	0.03	0.05	0.05	0.04	--
18	0.47	0.09	0.04	0.02	0.03	0.02	0.02	0.03	0.04	0.02	0.02	--
19	0.44	0.20	0.07	0.03	0.02	0.03	0.03	0.04	0.04	0.05	0.03	--
20	0.42	0.09	0.07	0.03	0.01	0.02	0.02	0.01	0.03	0.02	0.02	--
21	0.38	0.05	0.05	0.07	0.05	0.04	0.03	0.03	0.06	0.05	0.02	--
22	0.40	0.03	0.08	0.04	0.02	0.03	0.03	0.03	0.04	0.05	0.01	--
23	0.38	0.16	0.08	0.06	0.04	0.04	0.05	0.07	0.09	0.08	0.03	--
24	0.36	0.08	0.02	0.04	0.02	0.01	0.01	0.01	0.03	0.03	0.02	--
25	0.36	0.13	0.05	0.06	0.07	0.07	0.08	0.09	0.11	0.11	0.02	--
26	0.33	0.12	0.04	0.07	0.04	0.04	0.05	0.04	0.02	0.03	0.01	--
27	0.29	0.21	0.08	0.07	0.06	0.07	0.08	0.10	0.11	0.10	0.02	--
28	0.31	0.11	0.03	0.03	0.03	0.02	0.01	0.02	0.01	0.02	0.02	--
29	0.29	0.17	0.09	0.08	0.09	0.08	0.09	0.11	0.10	0.07	0.02	--
30	0.33	0.04	0.01	0.04	0.05	0.04	0.04	0.03	0.01	0.01	0.01	--
31	0.31	0.22	0.13	0.09	0.07	0.08	0.09	0.09	0.10	0.07	0.02	--
32	0.29	0.02	0.02	0.03	0.03	0.02	0.02	0.02	0.01	0.02	0.02	--
33	0.27	0.20	0.11	0.07	0.06	0.06	0.07	0.09	0.07	0.06	0.02	--
34	0.29	0.12	0.04	0.01	0.04	0.03	0.03	0.03	0.02	0.01	0.02	--
35	0.18	0.18	0.11	0.05	0.03	0.03	0.03	0.05	0.04	0.05	0.02	--
36	0.18	0.06	0.03	0.04	0.02	0.01	0.01	0.02	0.02	0.02	0.02	--
37	0.24	0.18	0.10	0.03	0.01	0.01	0.01	0.01	0.02	0.02	0.02	--
38	0.20	0.04	0.03	0.02	0.02	0.02	0.01	0.01	0.03	0.04	0.01	--
39	0.22	0.14	0.08	0.03	0.03	0.02	0.03	0.02	0.02	0.01	0.02	--
40	0.18	0.07	0.04	0.04	0.04	0.03	0.01	0.00	0.02	0.02	0.01	--

(5.2.4)	TABLE: Harmonic current limit test (EN 61000-3-2)						P
Model	NBQ800						
Harmonic	L1		--		--		Limits -A
	Magnitude (A)	% of I	Magnitude (A)	% of I	Magnitude (A)	% of I	
02	0.17	--	--	--	--	--	1.08
03	0.09	--	--	--	--	--	2.30
04	0.08	--	--	--	--	--	0.43
05	0.15	--	--	--	--	--	1.14
06	0.02	--	--	--	--	--	0.30
07	0.05	--	--	--	--	--	0.77
08	0.02	--	--	--	--	--	0.23
09	0.01	--	--	--	--	--	0.40
10	0.01	--	--	--	--	--	0.18
11	0.01	--	--	--	--	--	0.33
12	0.01	--	--	--	--	--	0.15
13	0.01	--	--	--	--	--	0.21
14	0.01	--	--	--	--	--	0.13
15	0.01	--	--	--	--	--	0.15
16	0.01	--	--	--	--	--	0.12
17	0.01	--	--	--	--	--	0.13
18	0.00	--	--	--	--	--	0.10
19	0.00	--	--	--	--	--	0.12
20	0.00	--	--	--	--	--	0.09
21	0.01	--	--	--	--	--	0.11
22	0.00	--	--	--	--	--	0.08
23	0.01	--	--	--	--	--	0.10
24	0.00	--	--	--	--	--	0.08
25	0.00	--	--	--	--	--	0.09
26	0.00	--	--	--	--	--	0.07
27	0.00	--	--	--	--	--	0.08
28	0.00	--	--	--	--	--	0.07
29	0.00	--	--	--	--	--	0.08
30	0.00	--	--	--	--	--	0.06
31	0.00	--	--	--	--	--	0.07
32	0.00	--	--	--	--	--	0.06
33	0.00	--	--	--	--	--	0.07
34	0.00	--	--	--	--	--	0.05
35	0.00	--	--	--	--	--	0.06
36	0.00	--	--	--	--	--	0.05
37	0.00	--	--	--	--	--	0.06
38	0.00	--	--	--	--	--	0.05
39	0.00	--	--	--	--	--	0.06
40	0.00	--	--	--	--	--	0.05
THD	--	3.25	--	--	--	--	--

(5.2.6)	TABLE: Direct current injection						P
Power P/Pn [%]	Measured DC output current						Limit [%]
	L1 [A]	L1 [%]	L2 [A]	L2 [%]	L3 [A]	L3 [%]	
95%	0.017	0.48	--	--	--	--	0.5%
66%	0.016	0.46	--	--	--	--	0.5%
33%	0.016	0.46	--	--	--	--	0.5%

Supplementary information: Main voltage 230V

5.4.3	TABLE: Active power reduction through setting provision (P control)		P
Test Conditions	Measurements		Limit
P/Pn [%]	P/P <sub>E</sub> max [%]	$\Delta P/P_{E\max}$ [%]	$\Delta P/P_n$ [%]
100	98.88	1.12	≤ 5%
90	85.91	4.09	
80	76.54	3.46	
70	67.10	3.90	
60	58.16	1.84	
50	48.98	1.02	
40	39.52	0.48	
30	29.93	0.07	
20	20.13	0.13	
10	10.15	0.15	
No disconnection occurs			

5.4.3	TABLE: Active power reduction through setting provision (P control)		P
Test Conditions	Measurements		Limit
P/Pn [%]	$\Delta P/\Delta t$ [%Pn/s]		$\Delta P/\Delta t$ [%Pn/s]
100->5	0.54		0.33-0.66
5->100	0.56		

5.4.3	TABLE: Active power reduction through setting provision (P control)		P
Test Conditions	Measurements	Limit	
P/Pn [%]	T <sub>response</sub> [s]	T <sub>response</sub> [s]	
100->0	1.5	≤ 5	
Note(s):			

5.5.2, 5.5.3, 5.5.4	TABLE: Interface switch (Functional safety)		N/A				
<input checked="" type="checkbox"/> Integrated interface switch							
<input checked="" type="checkbox"/> Complied with DIN EN 62109-2							
Switch manufacturer and type: Xiamen Hongfa Electroacoustics Co., Ltd; HF115F							
Response time of interface switch for integrated NS protection: 20ms							
The max. initial short-circuited current of PGU I <sub>k</sub> "': 1.52A							
No.	component No.	fault	test voltage (V)	test time	fuse No.	fuse current (A)	result
1.							
Supplement: s-c: short-circuited, o-c: open-circuited, o-l: overload							

6.5.2(5.5.7)		TABLE: Protection devices and protection settings (OV/UV)				P
Condition	Setting U/Un [%]	Measurement				Limitation $\Delta U/Un$ [%]
		Trip value [V]				
		L123	L1	L2	L3	
U>>	125	--	291.43	--	--	$\leq \pm 1.0$
U<	80	--	186.68	--	--	
U<<	45	--	108.25	--	--	
Condition	Setting U/Un [%]	Measurement				Limitation $\Delta U/Un$ [%]
		Trip value [V]				
		L123	L1-L2	L2-L3	L3-L1	
U>>	125	--	--	--	--	$\leq \pm 1.0$
U<	80	--	--	--	--	
U<<	45	--	--	--	--	
Condition	Setting [ms]	Measurement				Limitation [ms]
		Trip time [ms]				
		L123	L1	L2	L3	
U>>	100	--	133	--	--	$\leq 200$
U<	3000	--	3020	--	--	3000-3100
U<<	300	--	373	--	--	300-400
Condition	Setting	Measurement				Limitation [ms]
		Trip time [ms]				
		L123	L1-L2	L2-L3	L3-L1	
U>>	100	--	--	--	--	$\leq 200$
U<	3000	--	--	--	--	3000-3100
U<<	300	--	--	--	--	300-400
Condition	Setting [s]	Measurement				Limitation [s]
		Trip time [s]				
		L123	L1	L2	L3	
U> 230->257.6	500	--	536	--	--	450-550
U> 230->248.4	No disconnect	--	No disconnect	--	--	No disconnect
U> 244->262.2	300	--	322	--	--	225-375
Note(s): Tests on L-L voltages are applicable to product over 30kVA.						

6.5.2(5.5.7) TABLE: Protection devices and protection settings (OF/UF)			P
Condition	Setting f [Hz]	Measurement	Limitation $\Delta f/f_n$ [%]
		Trip value [Hz]	
f>	51.5	51.5	≤±0.5
f<	47.5	47.6	
Condition	Setting [ms]	Measurement	Limitation [ms]
		Trip time [ms]	
f>	100	193.5	≤200
f<	100	170.0	≤200
Note(s):			

6.5.3 (5.5.10) TABLE: Islanding detection (per IEC 62116: 2014)						P
Power 100%						
Conditions	P <sub>R</sub> [W]	Q <sub>L</sub> [Var]	Q <sub>C</sub> [Var]	Q <sub>f</sub>	Trip time [ms]	Limitation [ms]
P <sub>R</sub> : -10% Q <sub>C</sub> : +10%	L1: 658	L1: 871	L1: 769	1.244	960	9000
	L2: --	L2: --	L2: --	--		
	L3: --	L3: --	L3: --	--		
P <sub>R</sub> : -10% Q <sub>C</sub> : +5%	L1: 653	L1: 831	L1: 769	0.224	820	9000
	L2: --	L2: --	L2: --	--		
	L3: --	L3: --	L3: --	--		
P <sub>R</sub> : -10% Q <sub>C</sub> : 0%	L1: 652	L1: 793	L1: 769	1.198	1894	9000
	L2: --	L2: --	L2: --	--		
	L3: --	L3: --	L3: --	--		
P <sub>R</sub> : -10% Q <sub>C</sub> : -5%	L1: 648	L1: 753	L1: 769	1.174	502	9000
	L2: --	L2: --	L2: --	--		
	L3: --	L3: --	L3: --	--		
P <sub>R</sub> : -10% Q <sub>C</sub> : -10%	L1: 646	L1: 714	L1: 769	1.1476	968	9000
	L2: --	L2: --	L2: --	--		
	L3: --	L3: --	L3: --	--		
P <sub>R</sub> : -5% Q <sub>C</sub> : +10%	L1: 692	L1: 871	L1: 769	1.183	500	9000
	L2: --	L2: --	L2: --	--		
	L3: --	L3: --	L3: --	--		
P <sub>R</sub> : -5% Q <sub>C</sub> : -10%	L1: 676	L1: 714	L1: 766	1.0940	833	9000
	L2: --	L2: --	L2: --	--		
	L3: --	L3: --	L3: --	--		
P <sub>R</sub> : 0% Q <sub>C</sub> : +10%	L1: 725	L1: 871	L1: 769	1.129	1083	9000
	L2: --	L2: --	L2: --	--		
	L3: --	L3: --	L3: --	--		
P <sub>R</sub> : -5% Q <sub>C</sub> : +5%	L1: 685	L1: 831	L1: 766	1.164	585	9000
	L2: --	L2: --	L2: --	--		
	L3: --	L3: --	L3: --	--		
P <sub>R</sub> : -5% Q <sub>C</sub> : 0%	L1: 683	L1: 793	L1: 766	1.139	1209	9000
	L2: --	L2: --	L2: --	--		
	L3: --	L3: --	L3: --	--		
P <sub>R</sub> : -5% Q <sub>C</sub> : -5%	L1: 680	L1: 753	L1: 766	1.117	1737	9000
	L2: --	L2: --	L2: --	--		

	L3: --	L3: --	L3: --	--		
PR: 0% QC: +5%	L1: 720	L1: 831	L1: 769	1.111	1782	9000
	L2: --	L2: --	L2: --	--		
	L3: --	L3: --	L3: --	--		
PR: 0% QC: 0%	L1: 719	L1: 793	L1: 769	1.086	800	9000
	L2: --	L2: --	L2: --	--		
	L3: --	L3: --	L3: --	--		
PR: 0% QC: -5%	L1: 714	L1: 753	L1: 769	1.0663	1703	9000
	L2: --	L2: --	L2: --	--		
	L3: --	L3: --	L3: --	--		
PR: +5% QC: +5%	L1: 754	L1: 831	L1: 769	1.0598	619	9000
	L2: --	L2: --	L2: --	--		
	L3: --	L3: --	L3: --	--		
PR: +5% QC: 0%	L1: 753	L1: 793	L1: 769	1.037	729	9000
	L2: --	L2: --	L2: --	--		
	L3: --	L3: --	L3: --	--		
PR: +5% QC: -5%	L1: 749	L1: 753	L1: 769	1.016	737	9000
	L2: --	L2: --	L2: --	--		
	L3: --	L3: --	L3: --	--		
PR: 0% QC: -10%	L1: 710	L1: 714	L1: 769	1.043	671	9000
	L2: --	L2: --	L2: --	--		
	L3: --	L3: --	L3: --	--		
PR: +5% QC: +10%	L1: 758	L1: 871	L1: 769	1.078	774	9000
	L2: --	L2: --	L2: --	--		
	L3: --	L3: --	L3: --	--		
PR: +5% QC: -10%	L1: 745	L1: 714	L1: 769	0.994	1097	9000
	L2: --	L2: --	L2: --	--		
	L3: --	L3: --	L3: --	--		
PR: +10% QC: +10%	L1: 788	L1: 868	L1: 766	1.034	160	9000
	L2: --	L2: --	L2: --	--		
	L3: --	L3: --	L3: --	--		
PR: +10% QC: +5%	L1: 782	L1: 828	L1: 765	1.017	417	9000
	L2: --	L2: --	L2: --	--		
	L3: --	L3: --	L3: --	--		
PR: +10% QC: 0%	L1: 782	L1: 791	L1: 766	0.995	281	9000
	L2: --	L2: --	L2: --	--		
	L3: --	L3: --	L3: --	--		
PR: +10% QC: -5%	L1: 781	L1: 753	L1: 769	0.9745	1126	9000
	L2: --	L2: --	L2: --	--		
	L3: --	L3: --	L3: --	--		
PR: +10% QC: -10%	L1: 779	L1: 714	L1: 769	0.951	331	9000
	L2: --	L2: --	L2: --	--		
	L3: --	L3: --	L3: --	--		
Power 66%						
Conditions	Pr [W]	Ql [Var]	Qc [Var]	Qf	Trip time [ms]	Limitation [ms]
PR: 0%	L1: 471	L1: 476	L1: 461	0.995	635	

Qc: -5%	L2: --	L2: --	L2: --	--		9000
	L3: --	L3: --	L3: --	--		
Pr: 0% Qc: -4%	L1: 472	L1: 482	L1: 461	0.998	360	9000
	L2: --	L2: --	L2: --	--		
	L3: --	L3: --	L3: --	--		
Pr: 0% Qc: -3%	L1: 473	L1: 486	L1: 461	1.001	990	9000
	L2: --	L2: --	L2: --	--		
	L3: --	L3: --	L3: --	--		
Pr: 0% Qc: -2%	L1: 473	L1: 492	L1: 461	1.007	523	9000
	L2: --	L2: --	L2: --	--		
	L3: --	L3: --	L3: --	--		
Pr: 0% Qc: -1%	L1: 474	L1: 497	L1: 461	1.009	292	9000
	L2: --	L2: --	L2: --	--		
	L3: --	L3: --	L3: --	--		
Pr: 0% Qc: 0%	L1: 475	L1: 502	L1: 461	1.013	887	9000
	L2: --	L2: --	L2: --	--		
	L3: --	L3: --	L3: --	--		
Pr: 0% Qc: +1%	L1: 475	L1: 507	L1: 461	1.017	778	9000
	L2: --	L2: --	L2: --	--		
	L3: --	L3: --	L3: --	--		
Pr: 0% Qc: +2%	L1: 476	L1: 512	L1: 461	1.020	283	9000
	L2: --	L2: --	L2: --	--		
	L3: --	L3: --	L3: --	--		
Pr: 0% Qc: +3%	L1: 474	L1: 515	L1: 461	1.029	572	9000
	L2: --	L2: --	L2: --	--		
	L3: --	L3: --	L3: --	--		
Pr: 0% Qc: +4%	L1: 474	L1: 520	L1: 461	1.032	433	9000
	L2: --	L2: --	L2: --	--		
	L3: --	L3: --	L3: --	--		
Pr: 0% Qc: +5%	L1: 475	L1: 525	L1: 461	1.037	822	9000
	L2: --	L2: --	L2: --	--		
	L3: --	L3: --	L3: --	--		
Power 33%						
Conditions	Pr [W]	Ql [Var]	Qc [Var]	Qf	Trip time [ms]	Limitation [ms]
Pr: 0% Qc: -5%	L1: 238	L1: 278	L1: 213	1.022	632	9000
	L2: --	L2: --	L2: --	--		
	L3: --	L3: --	L3: --	--		
Pr: 0% Qc: -4%	L1: 239	L1: 282	L1: 213	1.027	761	9000
	L2: --	L2: --	L2: --	--		
	L3: --	L3: --	L3: --	--		
Pr: 0% Qc: -3%	L1: 239	L1: 284	L1: 213	1.031	511	9000
	L2: --	L2: --	L2: --	--		
	L3: --	L3: --	L3: --	--		
Pr: 0% Qc: -2%	L1: 239	L1: 288	L1: 213	1.036	588	9000
	L2: --	L2: --	L2: --	--		
	L3: --	L3: --	L3: --	--		

P <sub>R</sub> : 0% Q <sub>c</sub> : -1%	L1: 239	L1: 291	L1: 213	1.044	651	9000
	L2: --	L2: --	L2: --	--		
	L3: --	L3: --	L3: --	--		
P <sub>R</sub> : 0% Q <sub>c</sub> : 0%	L1: 239	L1: 294	L1: 213	1.046	976	9000
	L2: --	L2: --	L2: --	--		
	L3: --	L3: --	L3: --	--		
P <sub>R</sub> : 0% Q <sub>c</sub> : +1%	L1: 240	L1: 297	L1: 213	1.048	583	9000
	L2: --	L2: --	L2: --	--		
	L3: --	L3: --	L3: --	--		
P <sub>R</sub> : 0% Q <sub>c</sub> : +2%	L1: 241	L1: 300	L1: 213	1.049	720	9000
	L2: --	L2: --	L2: --	--		
	L3: --	L3: --	L3: --	--		
P <sub>R</sub> : 0% Q <sub>c</sub> : +3%	L1: 234	L1: 303	L1: 213	1.085	401	9000
	L2: --	L2: --	L2: --	--		
	L3: --	L3: --	L3: --	--		
P <sub>R</sub> : 0% Q <sub>c</sub> : +4%	L1: 234	L1: 306	L1: 213	1.087	674	9000
	L2: --	L2: --	L2: --	--		
	L3: --	L3: --	L3: --	--		
P <sub>R</sub> : 0% Q <sub>c</sub> : +5%	L1: 235	L1: 309	L1: 213	1.091	700	9000
	L2: --	L2: --	L2: --	--		
	L3: --	L3: --	L3: --	--		

8.3(5.6)	TABLE: Connection conditions and synchronization (Reconnection)				P
Condition	Measurement		Limitation		
	Reconnection	Delay time [s]	Reconnection	Delay time [s]	
f<47.45Hz	No	--	No	≥60	
f≥47.55Hz	Yes	216.3	Yes	≥60	
f>50.15Hz	No	--	No	≥60	
f≤50.05Hz	Yes	80.1	Yes	≥60	
U<0.84Un	No	--	No	≥60	
U≥0.86Un	Yes	72.8	Yes	≥60	
U>1.11Un	No	--	No	≥60	
U≤1.09Un	Yes	60.4	Yes	≥60	
Note(s):					

Appendix table 2 -Photos of the product

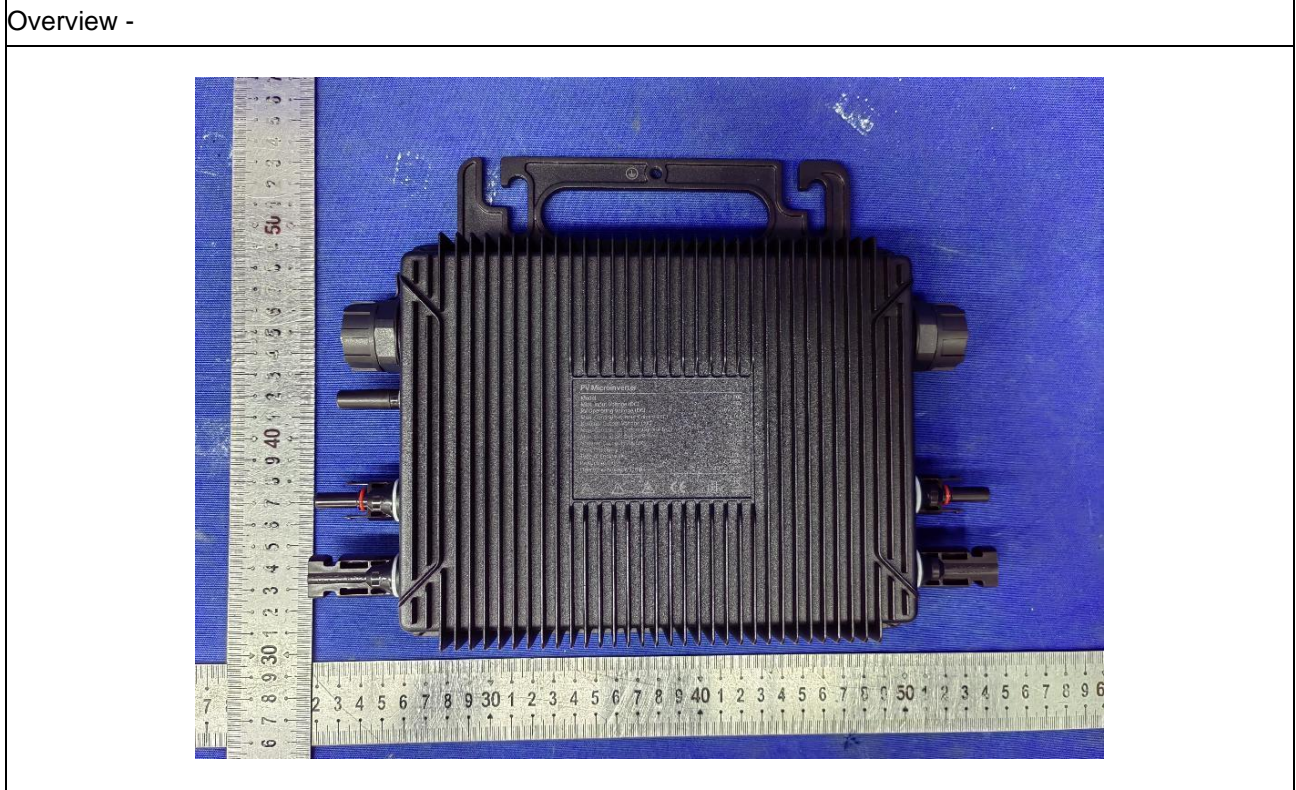
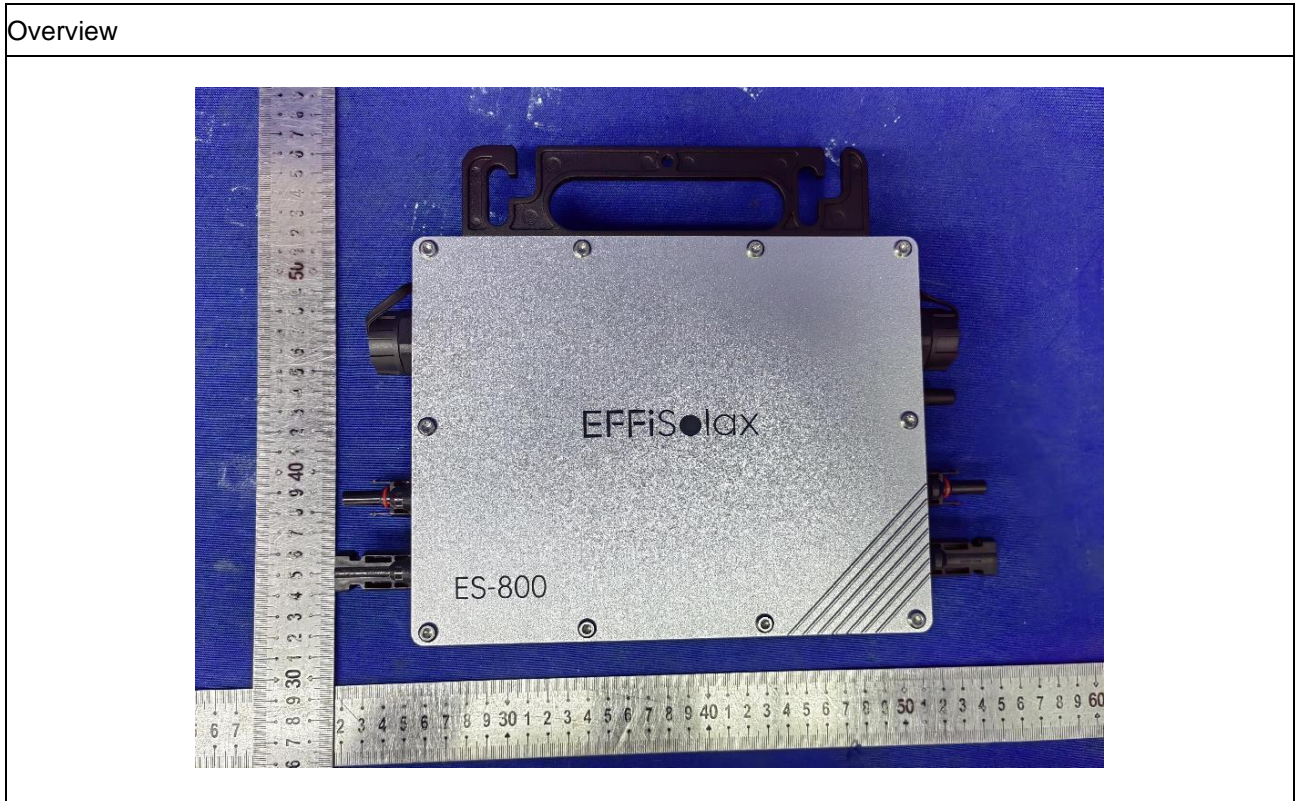

Overview

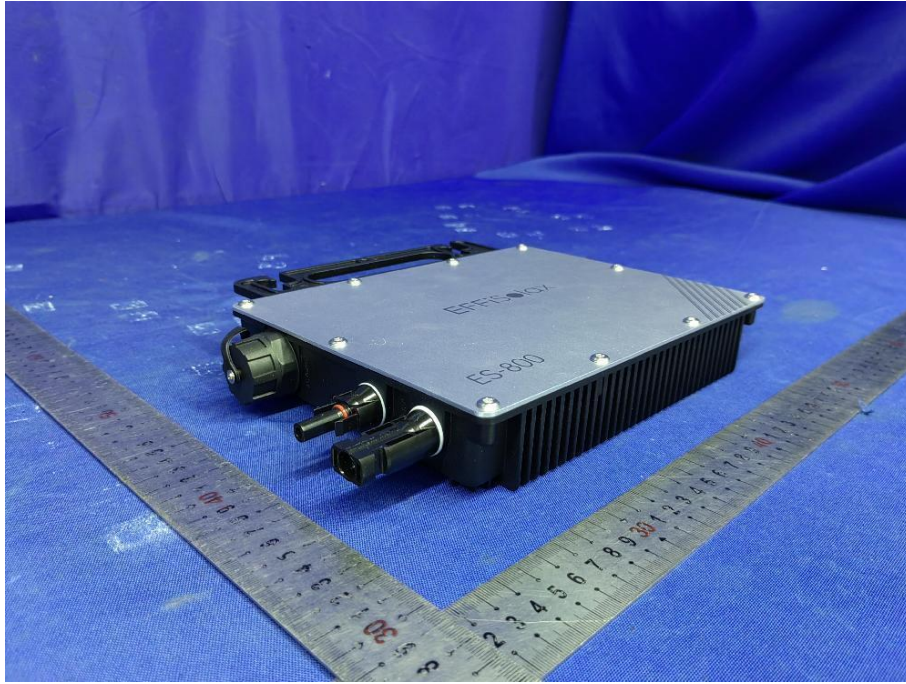

Overview -

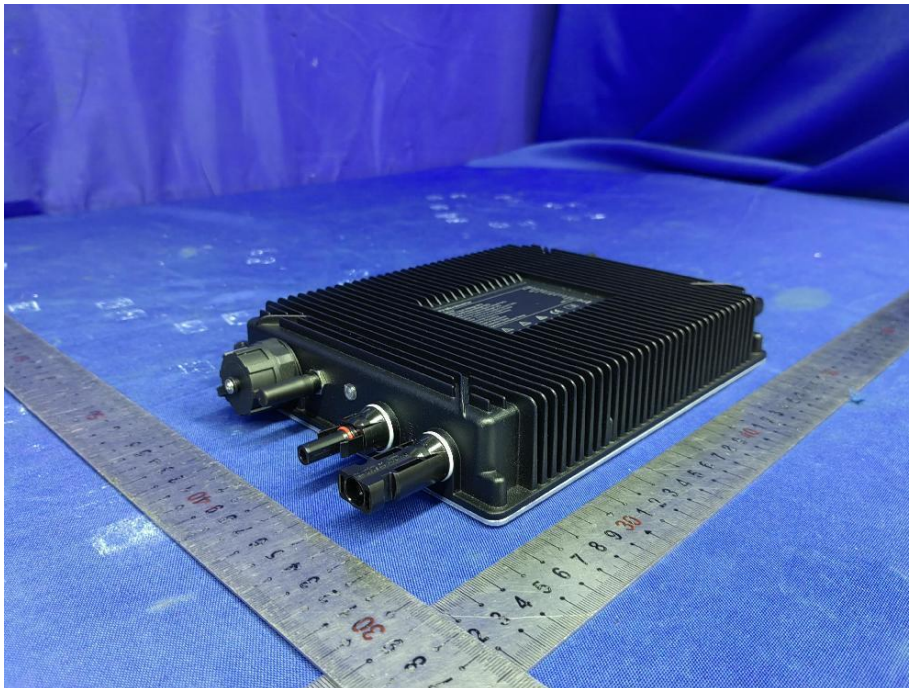

Inside view

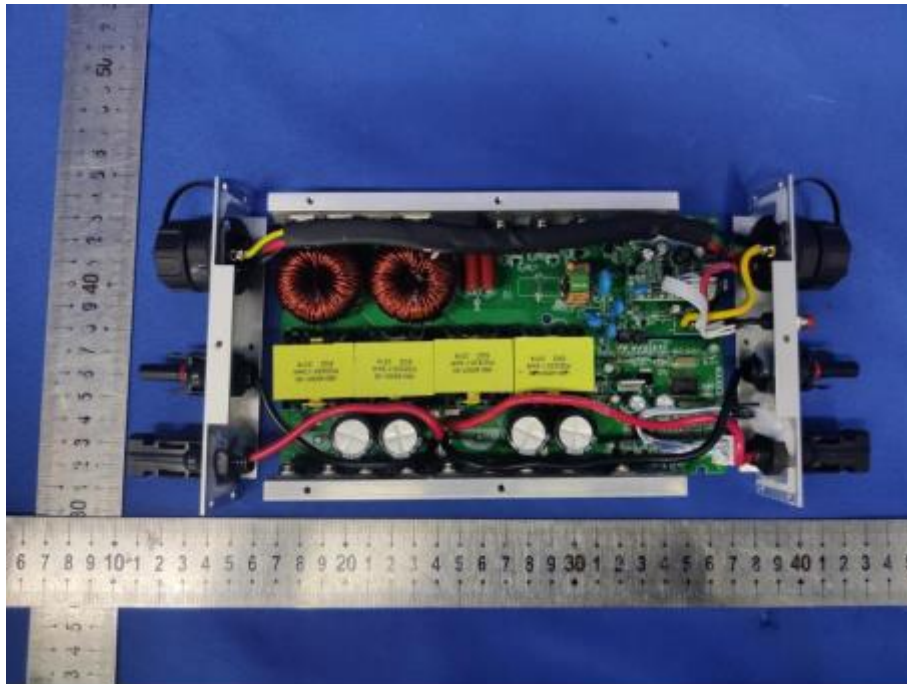

Inside view

