

X Series I/O Modules

2CH RS485/RS232+12DI Module X28

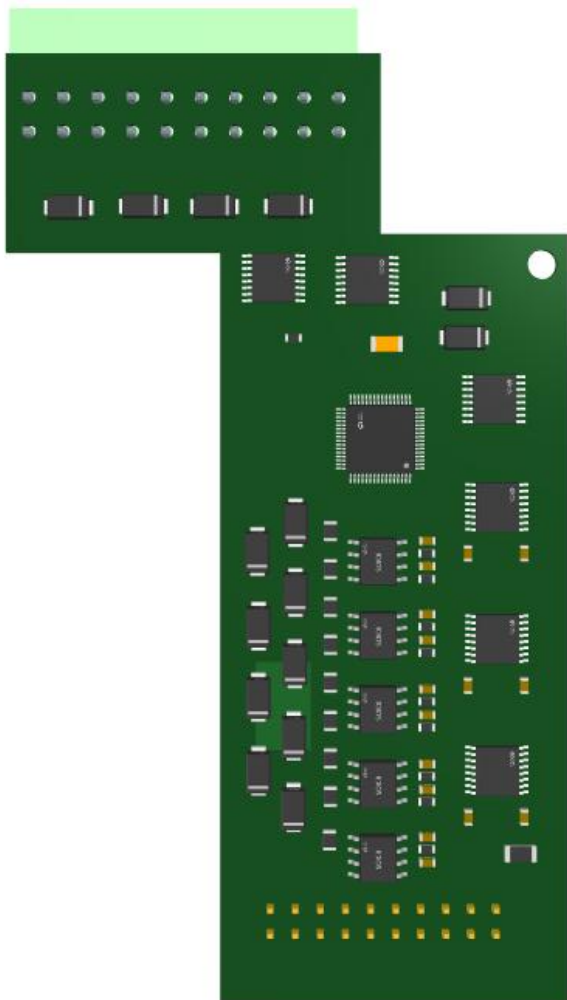

X28 User Manual

Version: V1.0

Date: 2025-4-9

Shenzhen Beilai Technology Co.,Ltd

Website: <https://www.bliiot.com>

Preface

Thanks for choosing BLIIOT X series I/O modules. These operating instructions contain all the information you need for operation of X series I/O modules.

Copyright

This user manual is owned by Shenzhen Beilai Technology Co., Ltd. No one is authorized to copy, distribute or forward any part of this document without written approval of Shenzhen Beilai Technology. Any violation will be subject to legal liability.

Disclaimer

This document is designed for assisting user to better understand the device. As the described device is under continuous improvement, this manual may be updated or revised from time to time without prior notice. Please follow the instructions in the manual. Any damages caused by wrong operation will be beyond warranty.

Revision History

Revision Date	Version	Description	Owner
2025/4/9	V1.0	Initial Release	PH

Table of Contents

1 Introduction	4
1.1 Overview	4
1.2 Technical Specifications	4
1.3 Model Selection	5
2 Wiring	6
2.1 Terminal Definitions	6
2.2 Connection Example	7
2.2.1 RS485 Connection	7
2.2.2 RS232 Connection	8
2.2.3 DI Dry Contact Connection	9
2.2.4 DI Wet Contact Positive Power Connection	10
2.2.5 DI Wet Contact Negative Power Connection	11
3 Warranty Terms	11
4 Technical Support	11

1 Introduction

1.1 Overview

X28 is an I/O expansion module specifically designed for the ARMxy series ARM embedded industrial computers. It features electrical isolation, over-voltage protection, ESD protection, fault protection, and over-current protection circuits to ensure stability and reliability in complex industrial environments.

1.2 Technical Specifications

Name	Parameter	Description
Power Supply	Operating Power	Internal Voltage
	Operating Voltage	12V-24V
	Power Consumption	2W
RS485/RS232	Channel	2 Channels
	Transmission Mode	Optional: 2×RS232 or 2×RS485
	Maximum Baud Rate	RS232: 115kbps RS485: 10Mbps
	Data Bits	RS232: 5-bit, 6-bit, 7-bit, 8-bit (configurable) RS485: 5-bit, 6-bit, 7-bit, 8-bit (configurable)
	Stop Bits	RS232: 1-bit, 2-bit (configurable) RS485: 1-bit, 2-bit (configurable)
	Parity	RS232: Odd parity, Even parity, No parity (configurable) RS485: Odd parity, Even parity, No parity (configurable)
	Flow Control	RS232: Not supported RS485: Not supported
	Impedance	RS232: Input impedance 300 Ω, Output impedance 3 kΩ RS485: 120 Ω
	Measured Distance and Operating Baud Rate	RS232: 15 meters (baud rate ≤ 1200 bps) RS485: 200 meters (baud rate ≤ 115200 bps)
	Supports Multi-Drop Communication	RS232: Not supported RS485: Requires custom development
	Communication Mode	RS232: Full-duplex / Half-duplex / Simplex RS485: Unidirectional Half-duplex / Simplex

	Data Transmission Mode	RS232: Transmit and receive mode, Receive-only mode, Transmit-only mode RS485: Transmit and receive mode, Receive-only mode, Transmit-only mode	
	Logic Level	RS232	Logic "1": 1.5V Logic "0": 2.4V
		RS485	Logic "1": -3V Logic "0": +3V
	Maximum Output Current per Channel	100mA (at 26°C)	
	Isolation Protection	2KVrms (built-in)	
	Communication Cable Requirements	Shielded twisted pair cable	
Digital Input	Channel	12 Channels	
	Trigger Mode	Low-level trigger or high-level trigger (optional)	
	Dry/Wet Contact	Optional	
	Logic Level	Logic "1": +9 to +12VDC Logic "0": -3 to +5VDC	
	Isolation Protection	2KVrms	
Certifications	EMC	IEC 61000-4-2 (ESD) Level 3	
		IEC 61000-4-4 (EFT) Level 3	
		IEC 61000-4-5 (Surge) Level 3	

1.3 Model Selection

No.	Name	Model	Signal Type
1	2CH RS485/RS232 +12DI	X28	DI: High-Level Trigger / Low-Level Trigger RS485: Differential signal RS232: Digital signal

2 Wiring

2.1 Terminal Definitions

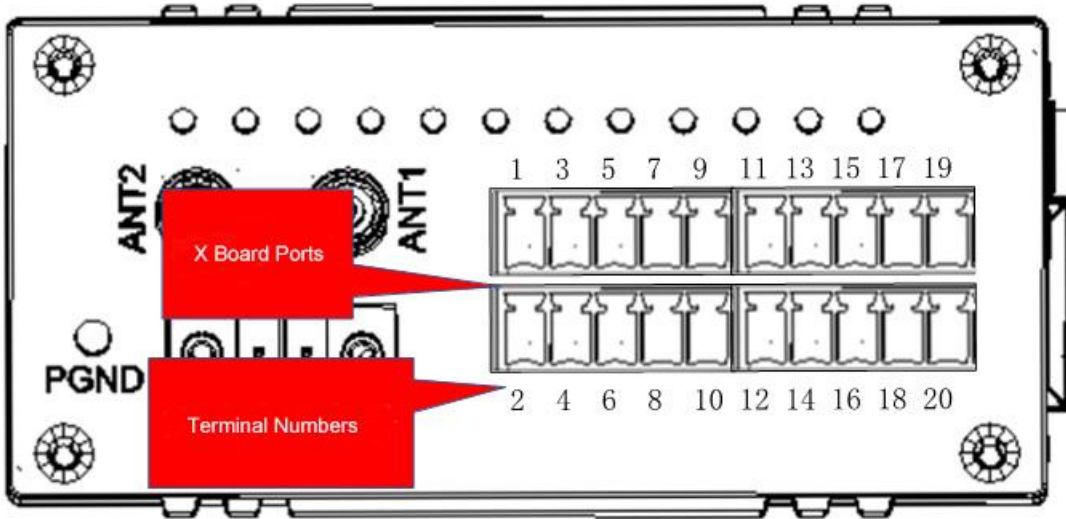

Notice: Please refer to the product's label for the specific terminal numbering sequence.

Terminal NO.	Definition	Description	Terminal NO.	Definition	Description
1	DI6	Digital Input 6	2	DI12	Digital Output 12
3	DI5	Digital Input 5	4	DI11	Digital Output 11
5	DI4	Digital Input 4	6	DI10	Digital Output 10
7	DI3	Digital Input 3	8	DI9	Digital Output 9
9	COM	Wet Contact Input Terminal	10	POWER	Output Protection Terminal
11	GND	Ground Terminal	12	GND	Ground Terminal
13	DI2	Digital Input 2	14	DI8	Digital Input 8
15	DI1	Digital Input 1	16	DI7	Digital Input 7
17	Channel 2-A	RS485-A RS232-TX	18	Channel 2-B	RS485-B RS232-RX
19	Channel 1-A	RS485-A RS232-TX	20	Channel 1-B	RS485-B RS232-RX

2.2 Connection Example

2.2.1 RS485 Connection

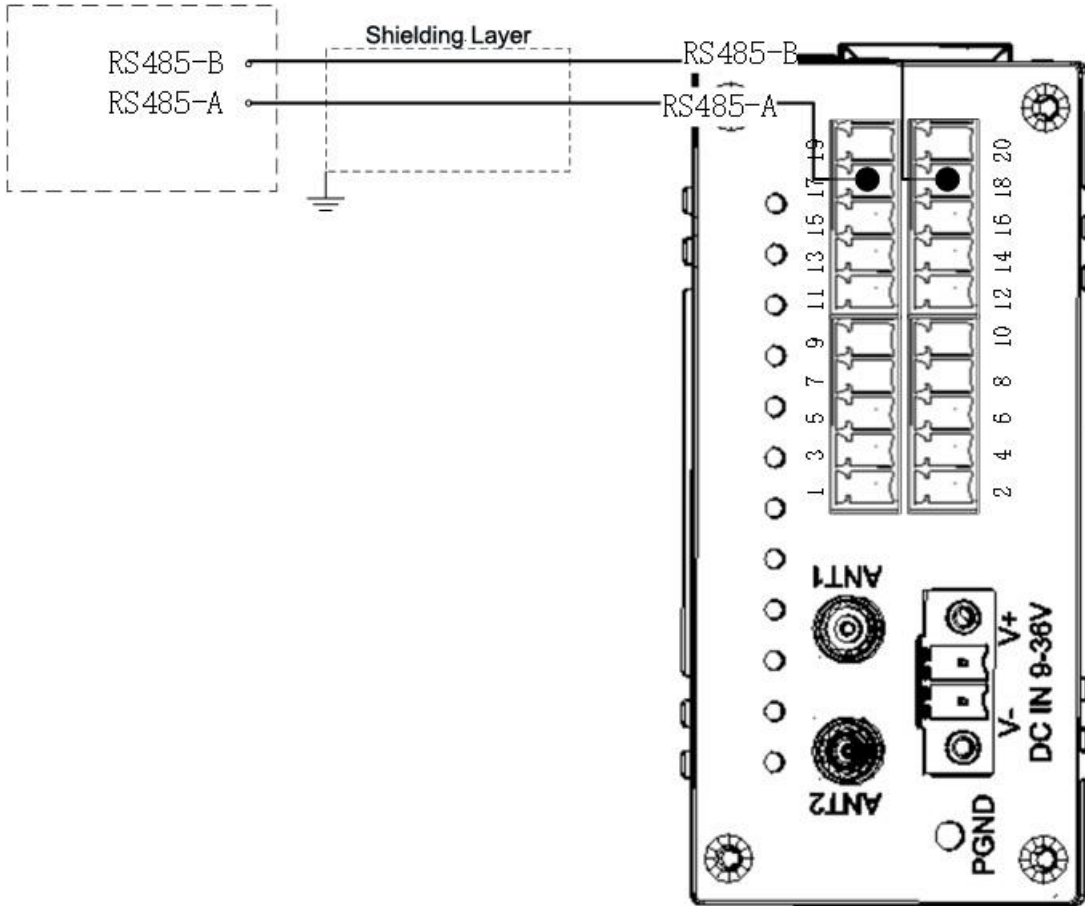

2.2.2 RS232 Connection

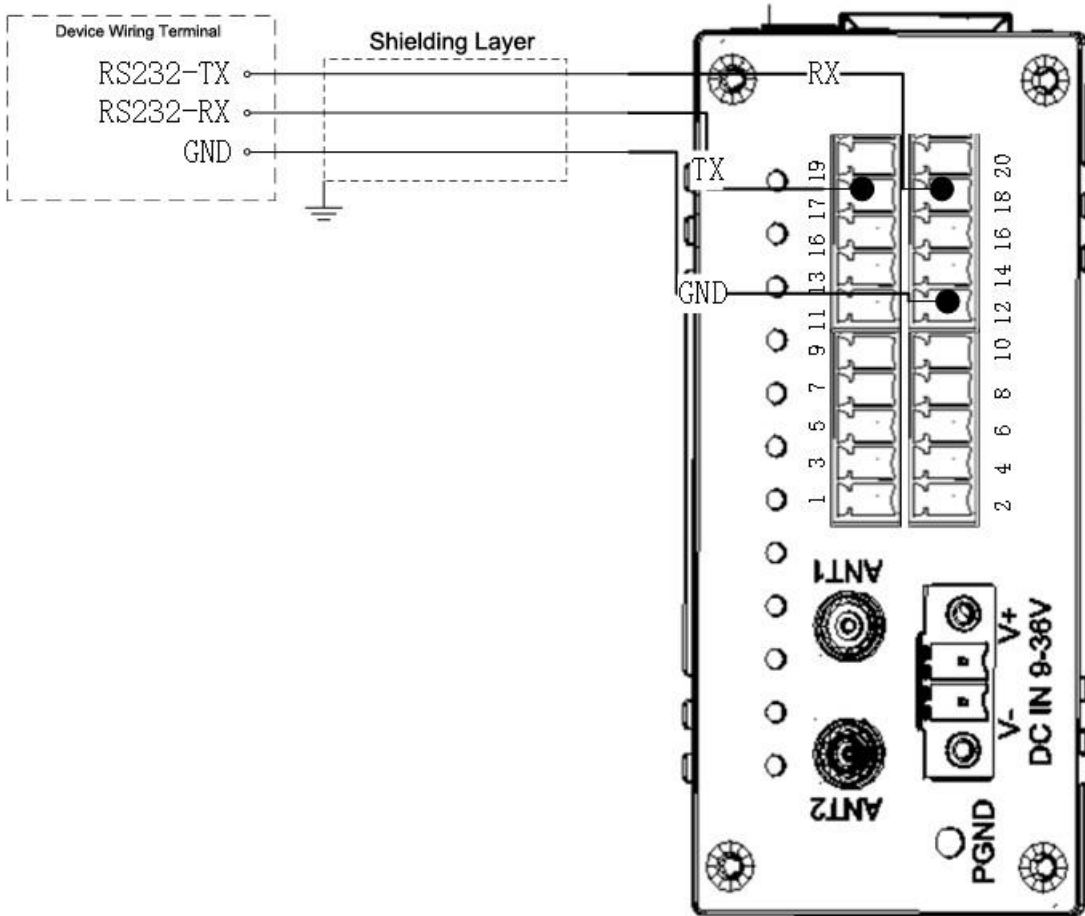

2.2.3 DI Dry Contact Connection

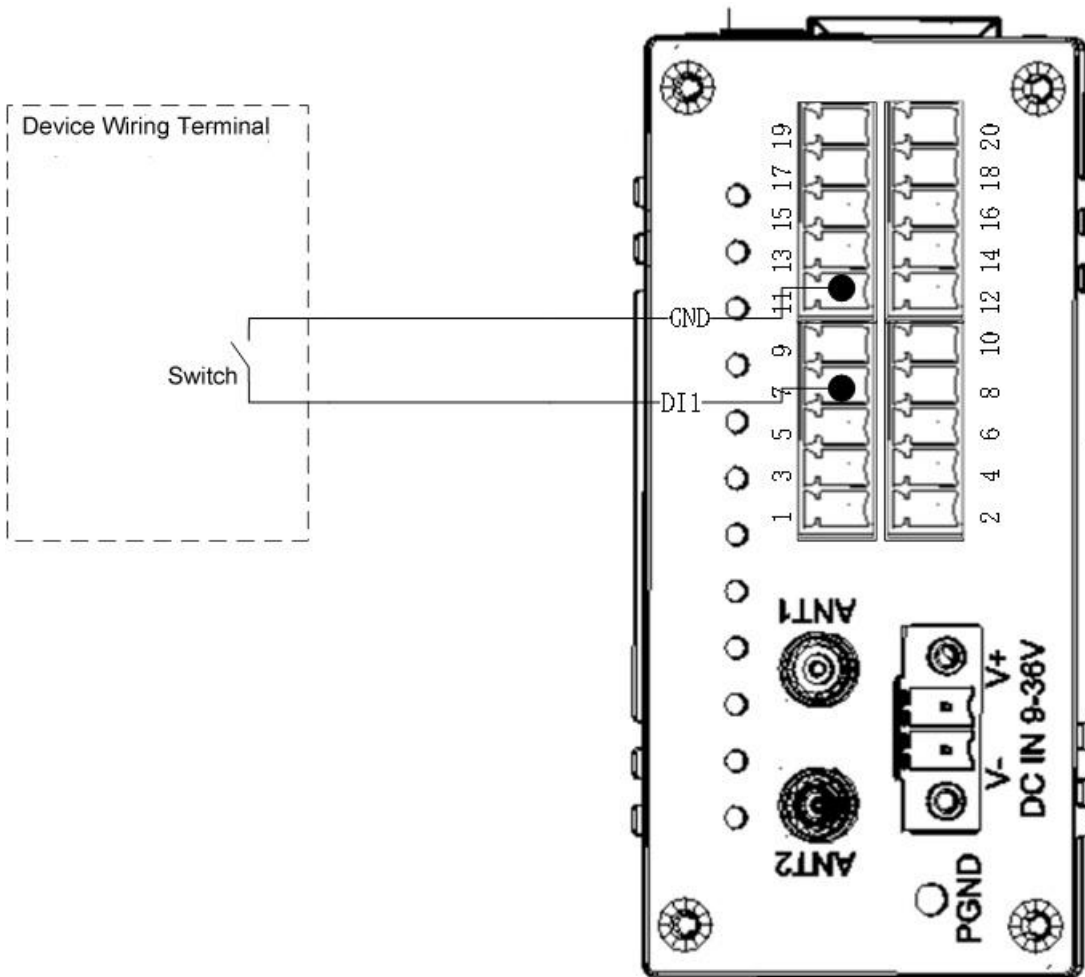

2.2.4 DI Wet Contact Positive Power Connection

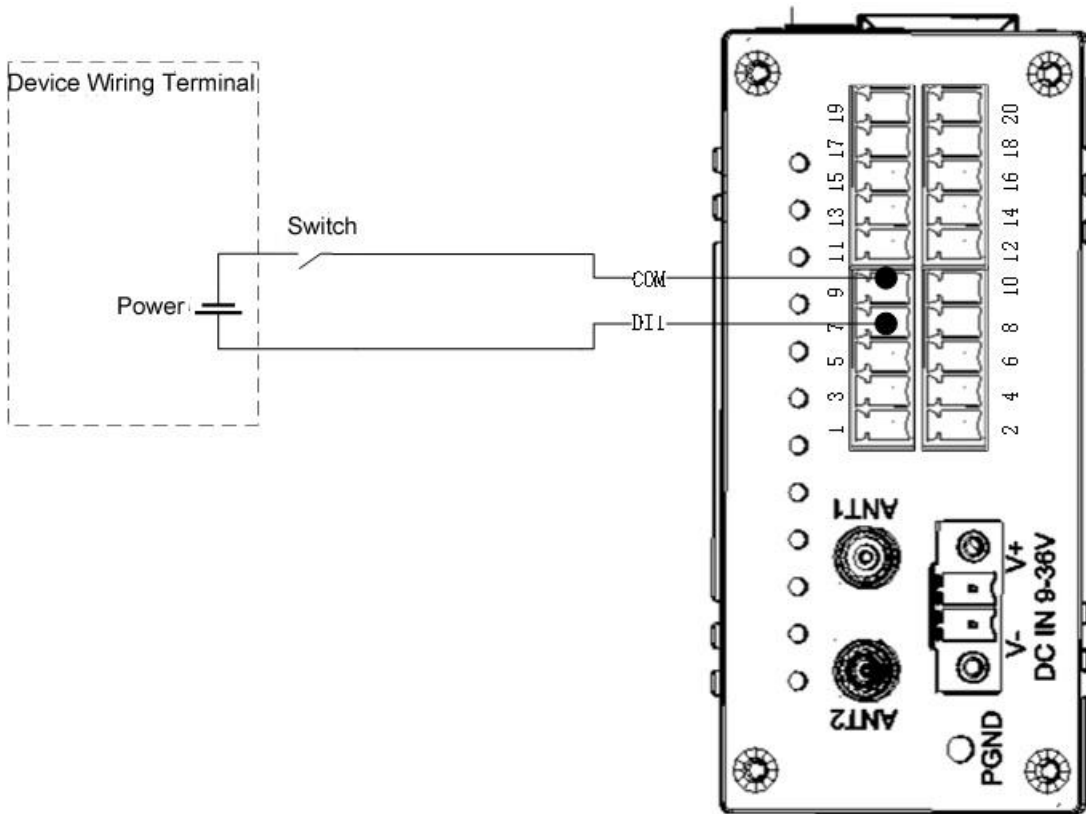

2.2.5 DI Wet Contact Negative Power Connection

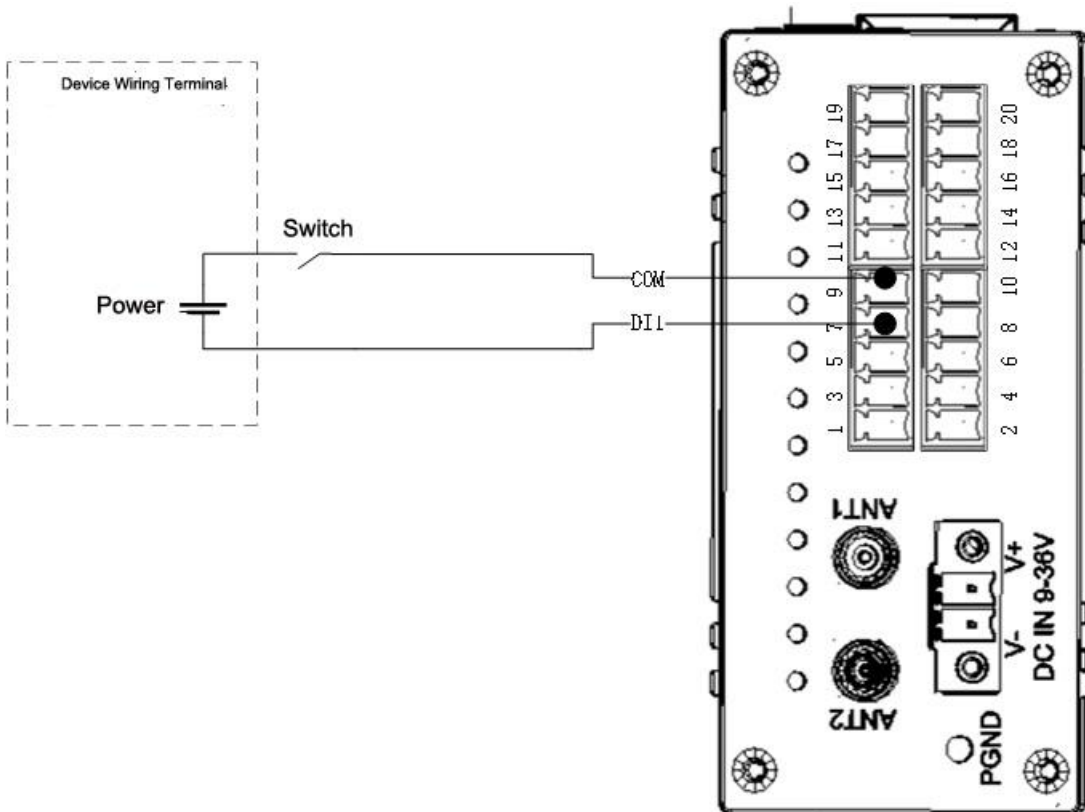

3 Warranty Terms

- 1) This equipment will be repaired free of charge for any material or quality problems within one year from the date of purchase.
- 2) This one-year warranty does not cover any product failure caused by man-made damage, improper operation, etc

4 Technical Support

Shenzhen Beilai Technology Co., Ltd

Website: <https://www.bliiot.com>