

**INSTRUCTION
MANUAL**



1/8 OFF ROAD SCALE

SRX8 GEN 4

**NITRO
POWERED**

SERPENT

INTRODUCTION

Thank you very much for selecting this Serpent rc car and thus become a member of the ever growing worldwide Serpent racing family. Serpent started in 1980 and has been growing its product-line and fan-base ever since.

The Serpent SRX8-Gen 4 is a state of the art 1/8 scale 4wd buggy, designed and developed to give you the true Serpent racing experience. The assembly manual will guide you through all the steps to complete the car, so you can hit the track with a good base-set-up soonest. The Serpent design department succeeded to create a superbly performing car combined with ease of assembly and maintenance. The high quality standards of all parts and hardware will make racing your Serpent car a very rewarding activity!

Through our team, website and social media we will keep you up-to-date on all developments of the Serpent cars. We hope to meet you on the track and through our various media! Enjoy the drive!

Team Serpent
Multiple World Champions

INSTRUCTIONS

Serpent's long tradition of excellence extends to the instruction manuals, and this instruction manual is no exception. The easy-to-follow layout is richly illustrated with 3D-rendered full-color images to make your building experience quick and easy. Following the instructions will result in a well-built, high-performance race-car that will soon be able to unleash its full potential at the racetrack. The kit includes bags, with bag numbers, which refer to the same step in the manual. Open only the indicated bag(s) per step and finish that part of the assembly. Remaining parts will be needed later on in the assembly process.

PLASTIC PARTS

The Serpent moulded parts are very durable and hard. When assembling longer screws in new composite parts, make sure to use new hex bits in your (power) tools. Pre-threading also helps to avoid screw damage.

SETUP

In certain assembly steps you will need to make basic adjustments, which will give you a good initial setup for your Serpent SRX8-Gen4. Fine-tuning the initial setup is an essential part of building a high-performance race car like your SRX8-Gen 4.

EXPLODED VIEWS AND PARTS LIST

The exploded views and parts list for the Serpent SRX8-Gen 4 are presented in the Reference Guide section in the back of this manual. The exploded views show all the parts of a particular assembly step along with the Serpent part number and hotlink to the Serpent website. Part numbers in orange indicates that this part is an optional. Optionals part names and numbers are showed below.

CUSTOMER SERVICE

Serpent has made a strong effort to make this manual as complete and clear as possible. Additional info may be published in our website: www.serpent.com or you may ask your dealer or the Serpent distributor for advice, or email Serpent direct: info@serpent.com. The Serpent Facebook, Twitter and Youtube pages give additional means of support and communications.

SAFETY

Read and take note of the 'Read this First section' before proceeding to assemble the car-kit. This car-kit is intended for persons aged 16 or older.

READ THIS FIRST!

- This is a highly technical hobby product, intended to be used in a safe racing environment. This car is capable of speeds in excess of 80 km/h or 50mph. Please follow these guidelines when building and operating this model.
- Parental guidance is required when the builder/user of this car is under 16.
- Follow the building instructions. If in doubt, contact your dealer or importer.
- Be sure to use the proper tools when assembling the car. Always exercise caution when using electric tools, knives and other sharp objects.
- Be careful when using liquids like lubrication oil, fuel or glue. Do not swallow.
- Follow the manufacturer's instruction in case you experience irritation after using the product.
- Be careful when operating the car. Stay away from any rotating parts such as wheels, gears and transmission. Stay away from motor, engine and exhaust pipe system or speedo during and immediately after use, as these parts may be very hot. We advise to use protective hand gloves.
- Only operate this car in a safe environment, like a special racing track or a closed parking lot. Avoid using this car on public roads, crowded places or near infants.
- Before operating this car, always check the mechanical status of the car. Also check that the transmitter and receiver frequencies correspond and are not used by any other racer at the same time. Check that the batteries of the transmitter and receiver- are fully charged.
- After use, always check all the mechanics of the car. We advise to clean the car immediately after use, and inspect the parts for wear or fractures. Replace when necessary. Do not use water, methanol, thinner or other solvents to clean the car.
- Empty the fuel tank (depending on model) if needed and disconnect the receiver battery.
- Store the car in a dry and heated place to avoid corrosion of metal parts.
- Avoid using this car in wet conditions as the water will cause corrosion on the metal parts and bearings and these parts will cease to function properly. If driven in the wet, ensure that all the electric equipment is waterproofed and after use, that all moving parts are dried immediately.

CONTENTS

• CENTER DIFF ASSEMBLY	4
• FR/RR DIFF ASSEMBLY	6
• REAR ASSEMBLY	8
• FRONT ASSEMBLY	17
• STEERING ASSEMBLY	23
• RADIO ASSEMBLY	27
• SHOCKS ASSEMBLY	34
• FINAL ASSEMBLY	38
• EXPLODED VIEWS	45
• TEAM SERPENT NETWORK	60

LINES DESCRIPTION

Each step contains a variety of numbers, lines, and symbols. The numbers represent the order in which the parts should be assembled. The lines are described below.



Step number; the order in which you should assemble the indicated parts



Length after assembly



Assembly path of one item into another



Group of items (within lines) should be assembled first



Direction the item should be moved



Glue one item to another



Press/insert one item into another



Connect one item to another



Gap between two items

ICONS DESCRIPTION

Each step contains a variety of symbols described below.



Carefully, read and check very well.



Apply a small amount of cyano glue. Use wear protection for eyes and hands.



Detail view to explain assembly or order of parts better.



Default set-up: This symbol indicates the default setup.



Grease: apply a small amount of grease to the parts shown.



Left and right parts should be assembled in the same way.



Thread lock: apply a small amount on the parts shown. Before to apply the threadlock, make sure to degrease the parts very well, as otherwise the threadlock will not work.



Silicone oil: use the indicated silicone oil for the shocks and differentials.



Parts or items not included in the kit.



Optional part, not standard in the kit.

STEP 1

CENTER DIFF BAG

1.1



1.2

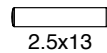
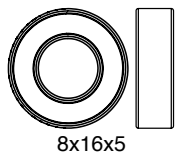
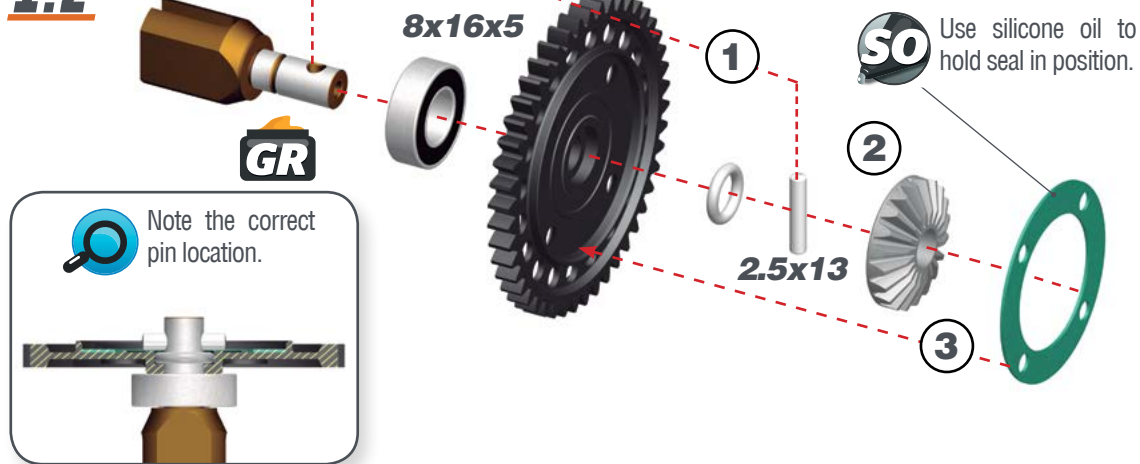

STEP 2

2.1

Add just enough oil to cover the large gear before assembling the small satellite gears and cross pins.

Use the silicone oil supplied in the kit. For the correct cst value please check the default setupsheet.

SO

2.2

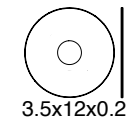
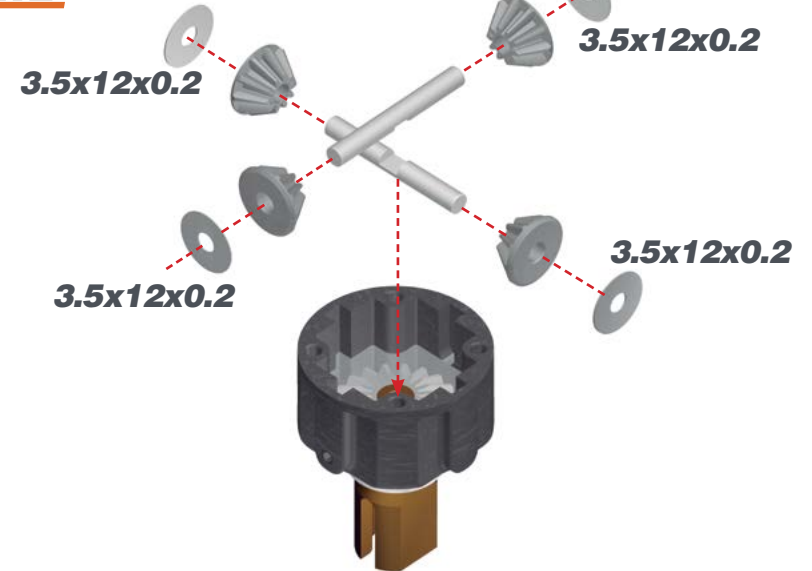

STEP 3

! Fill the differential with silicone oil 1 mm above the crosspin, do NOT overfill. Use the silicone oil supplied in the kit. For the correct cst value please check the default setupsheet.

SO



OIL LEVEL

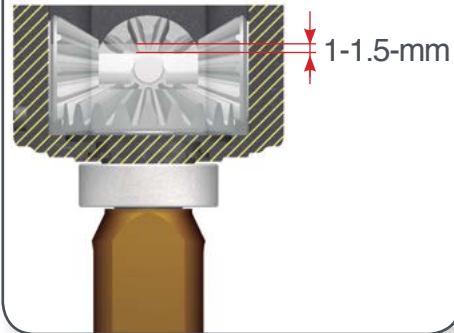

AMOUNT OF OIL IN THE DIFFS

Use a digital scale to measure the exact amount of oil in the diff.

Differential weight should be 44.2-44.4 grams.



STEP 4

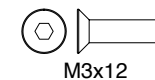
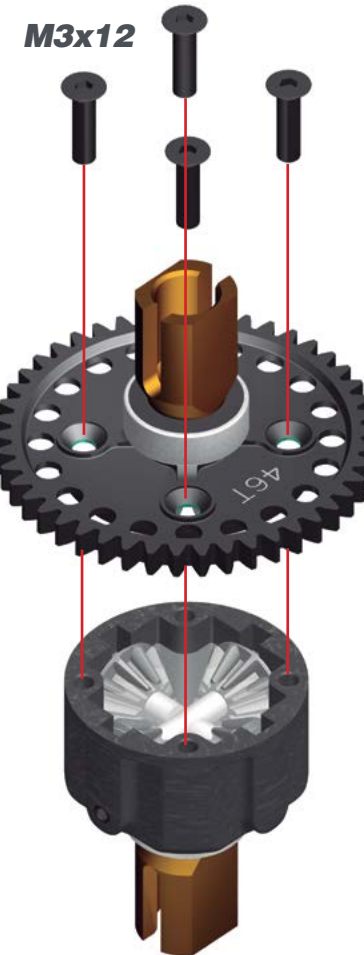

M3x12

STEP 5

FR/RR DIFF BAG

5.1



5.2

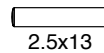
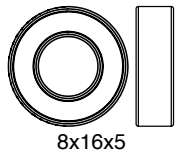
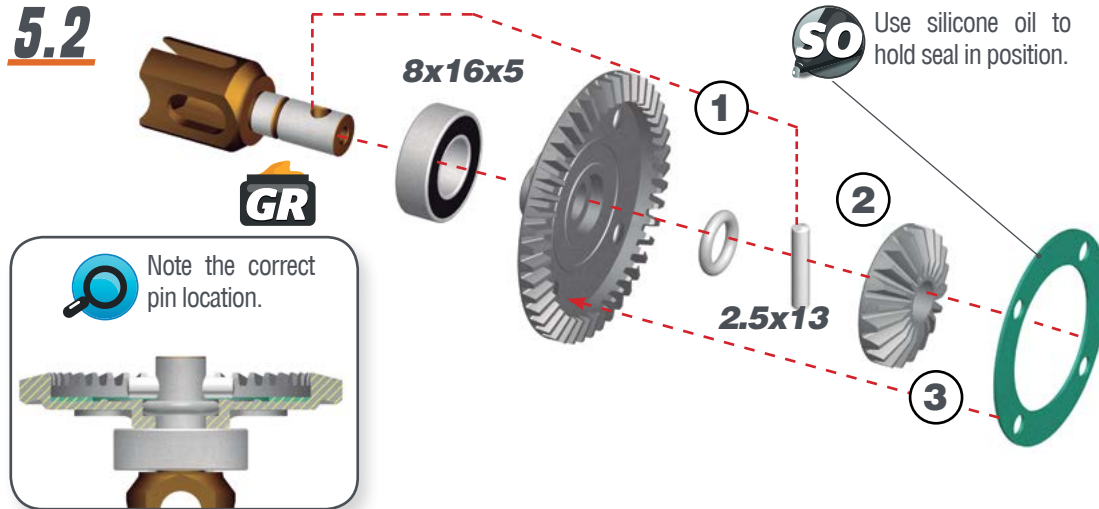

STEP 6

6.1

Add just enough oil to cover the large gear before assembling the small satellite gears and cross pins.

Use the silicone oil supplied in the kit. For the correct cst value please check the default setupsheet.

6.2

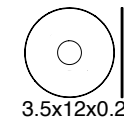
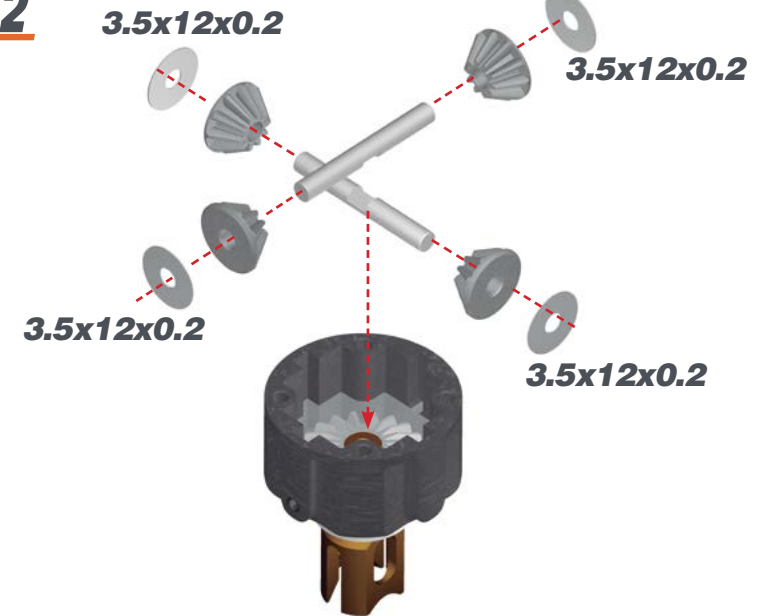

STEP 7

! Fill the differential with silicone oil 1 mm above the crosspin, do NOT overfill. Use the silicone oil supplied in the kit. For the correct cst value please check the default setupsheet.

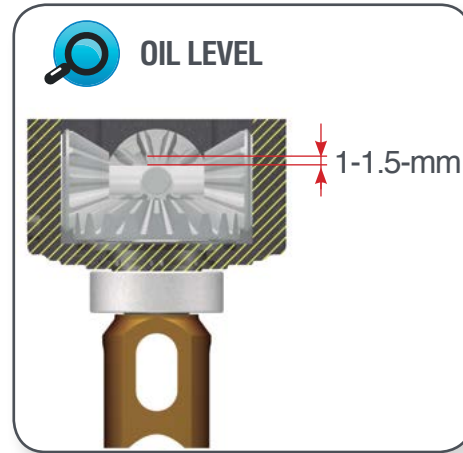

AMOUNT OF OIL IN THE DIFFS

Use a digital scale to measure the exact amount of oil in the diff.

Differential weight should be 42.6-42.9 grams.



STEP 8

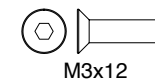
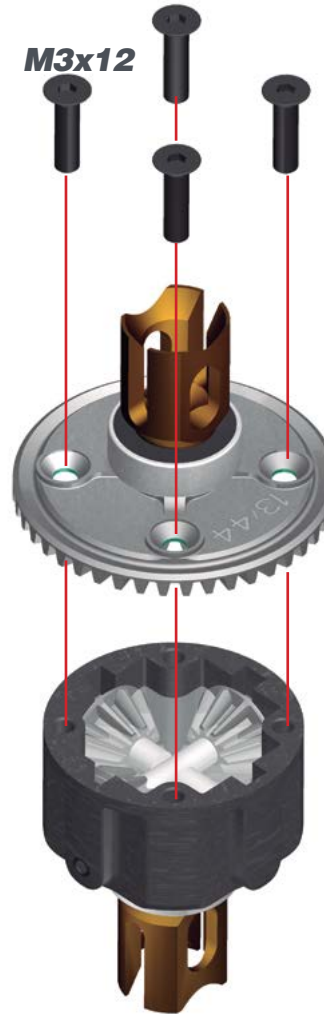

M3x12

STEP 9

BAG 1

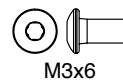
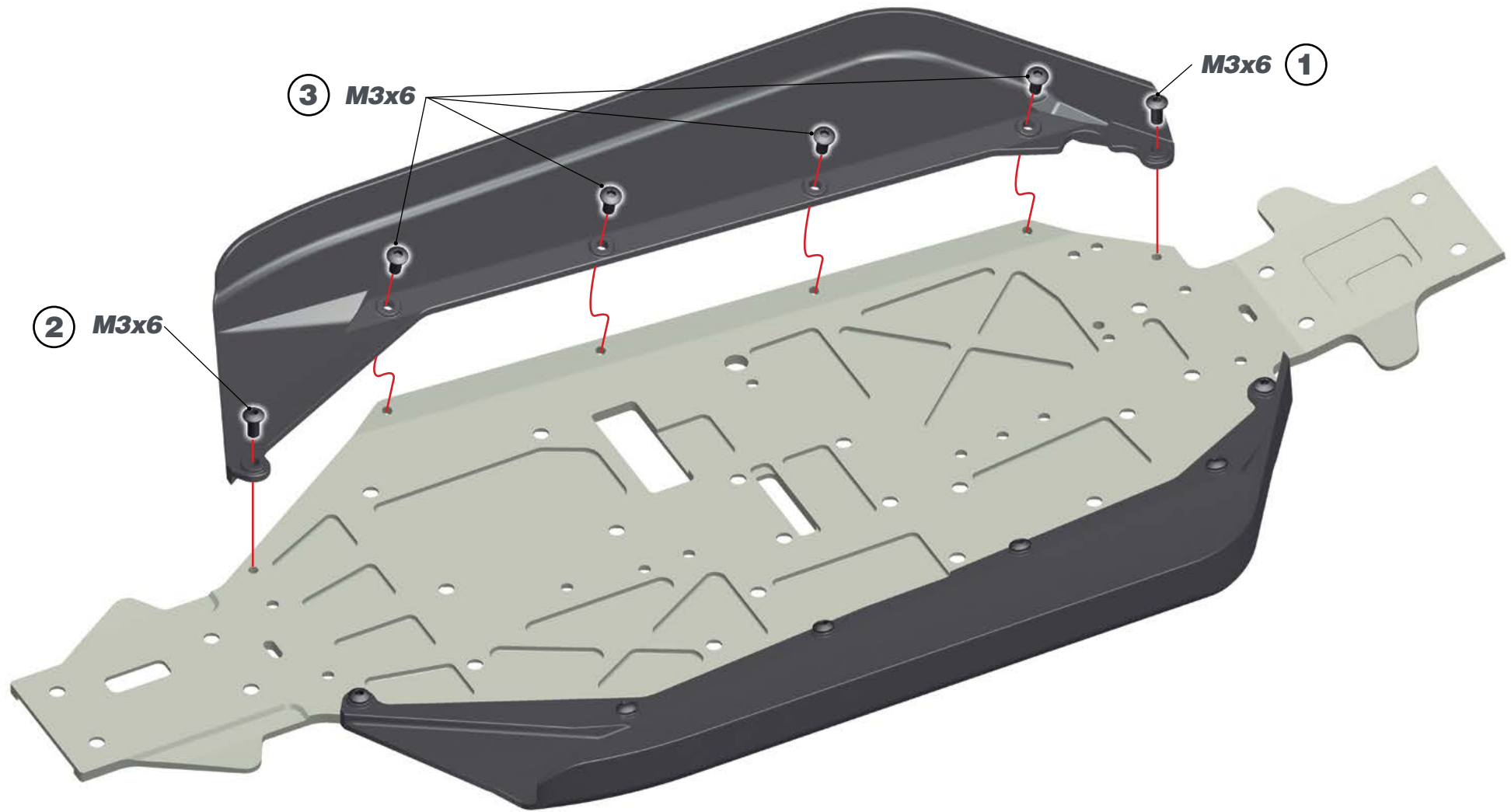

STEP 10

10.1

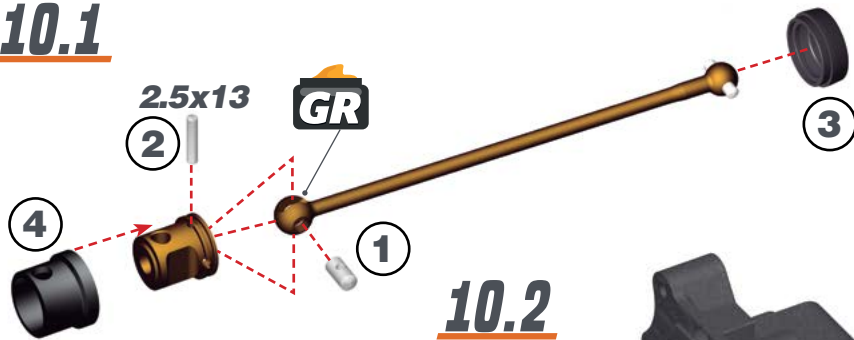

10.2

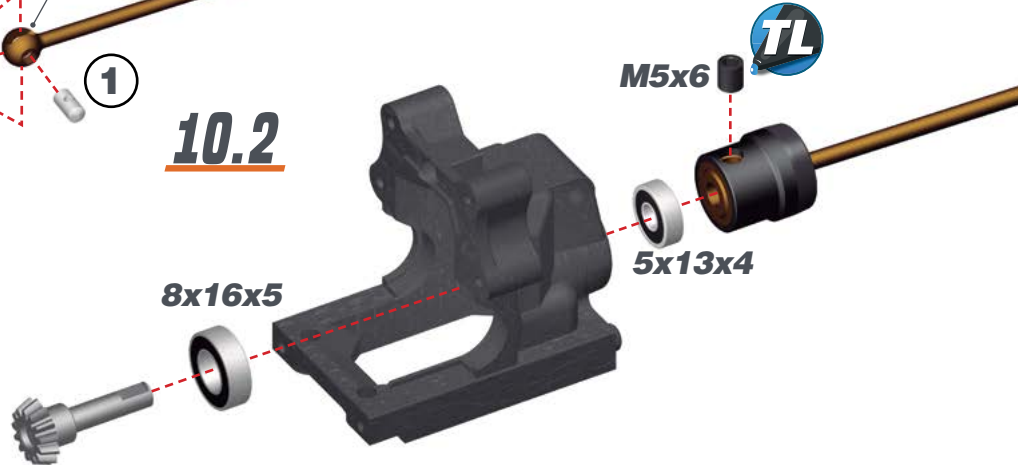

After building the differential with new gears, new differential case and bearings, the diff may feel a little tight. The connected parts need at least an hour run-time to create a perfect match. Attention: When you assemble the diff with too much initial play, the gears will not run-in properly and may wear quickly. After 1 or 2 hours of running the car, re-check the gear-mesh between the ring gear and the pinion. All parts should have run-in properly now. You may add or remove 8x11x0.1 shims as needed.

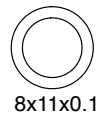
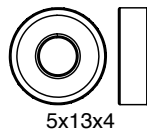
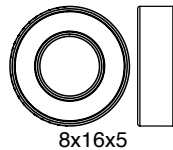
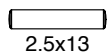
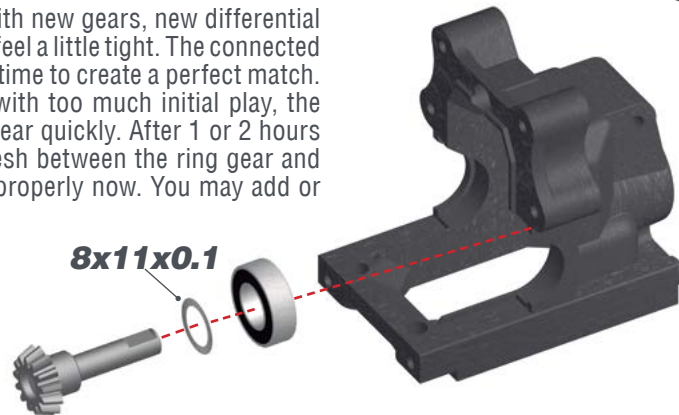

STEP 11

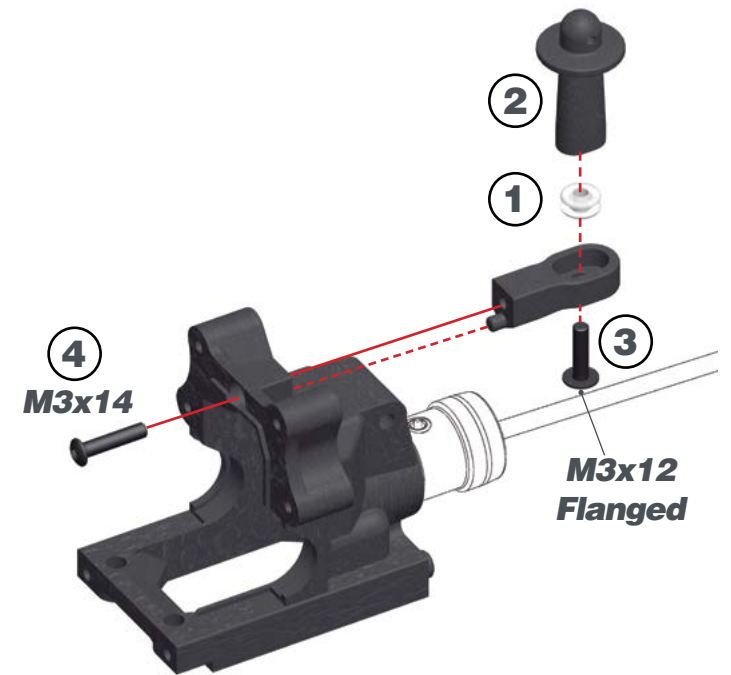

Note the correct grommet position.

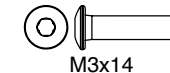
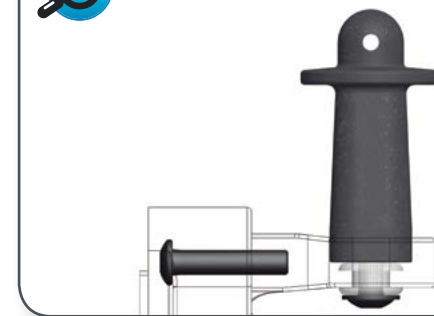

STEP 12

12.1  On the initial build, you will not be able to fit this shim. After 1 or 2 hours of running the car, re-check the gear-mesh between the ring gear and pinion. All the parts should have run in properly. You may need to add this 13x16x0.1 shim.

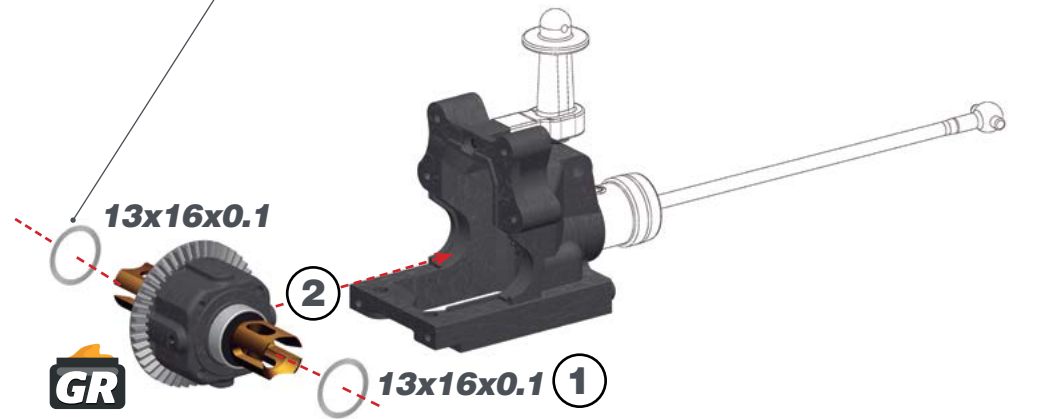
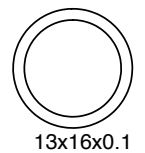
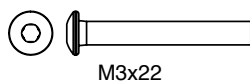
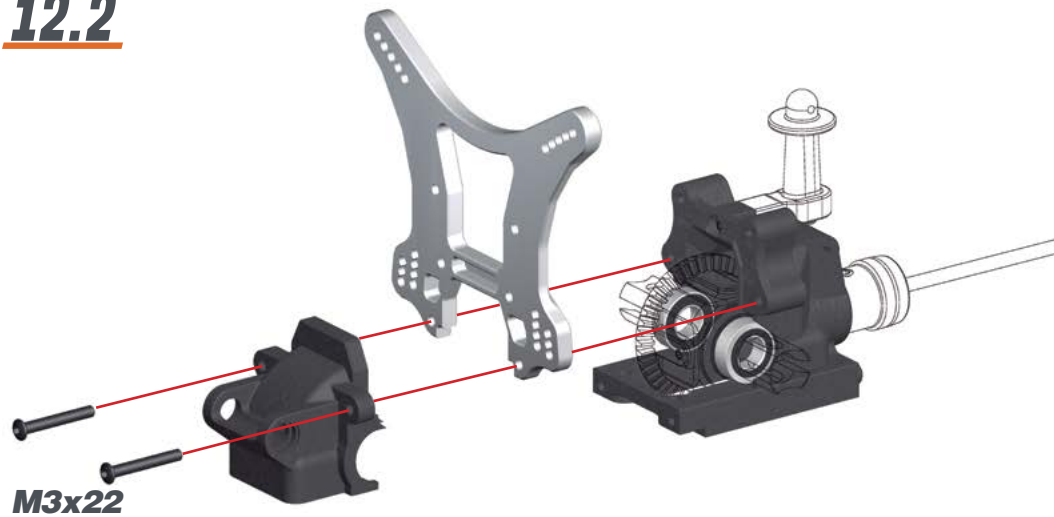
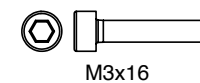
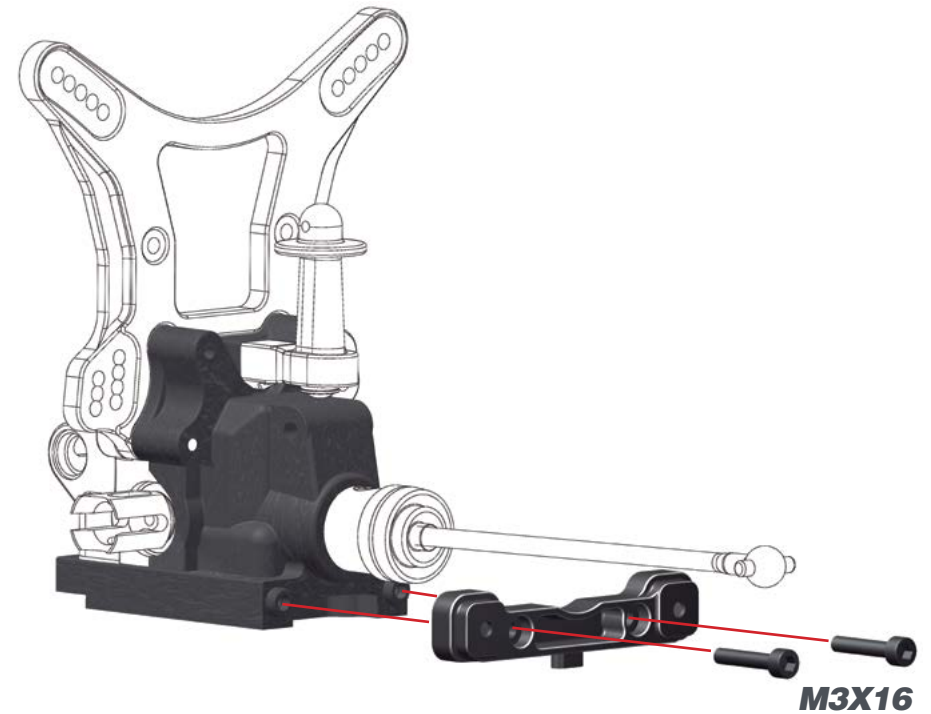
**12.2****STEP 13****BAG 2**

STEP 14

STEP 15

14.1 **L=R**



Tighten anti-roll bar cap until there is no play, and it moves freely.

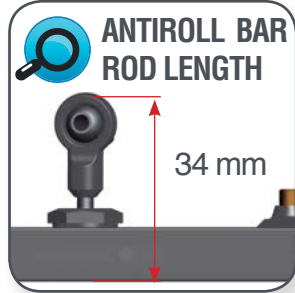

14.2

M2.5x6

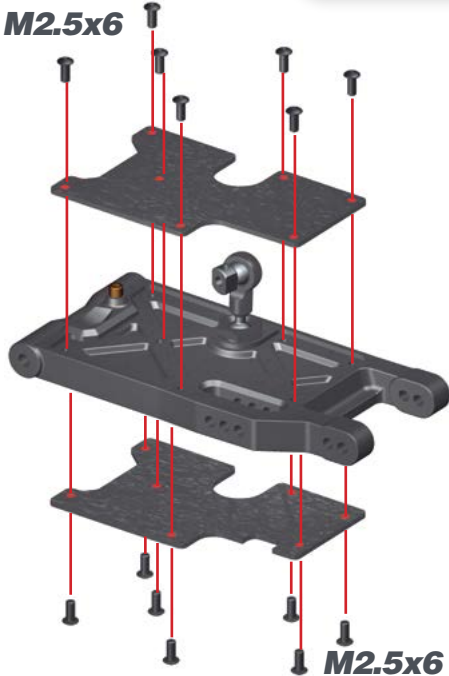

M2.5x6

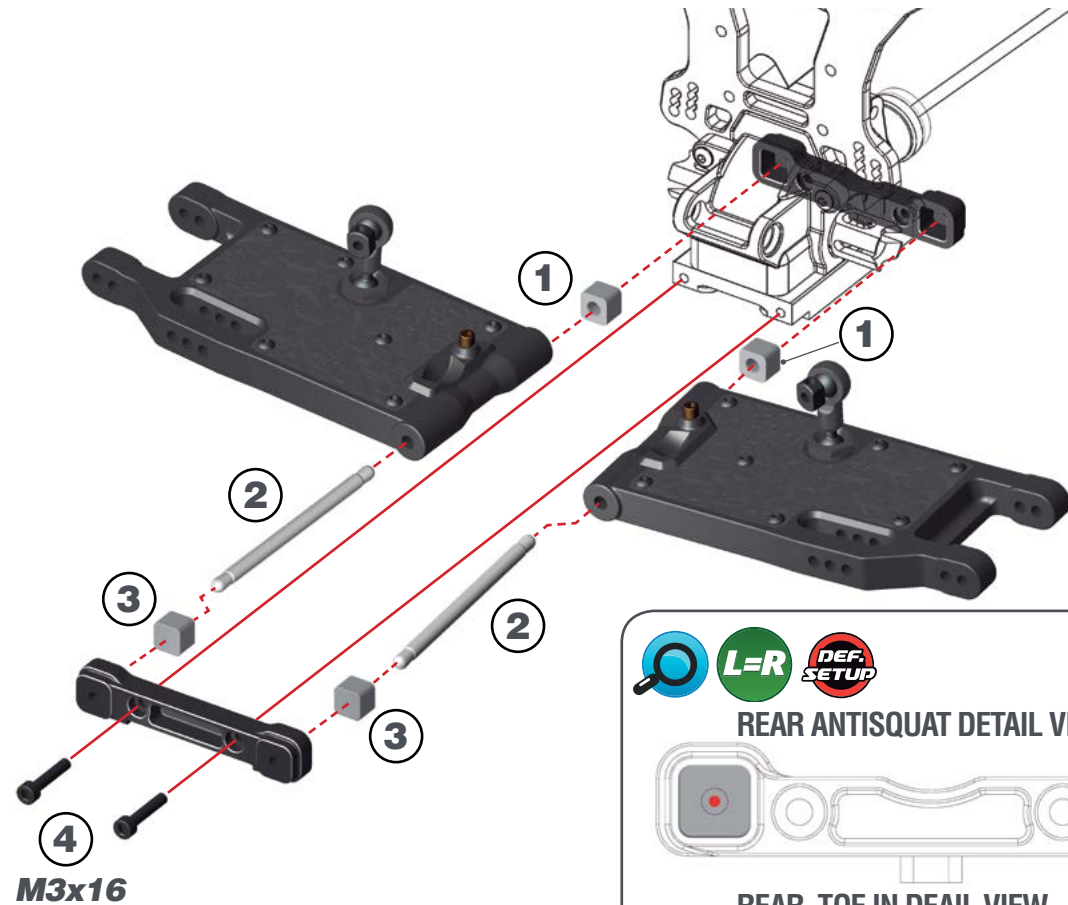
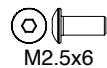

M3x16

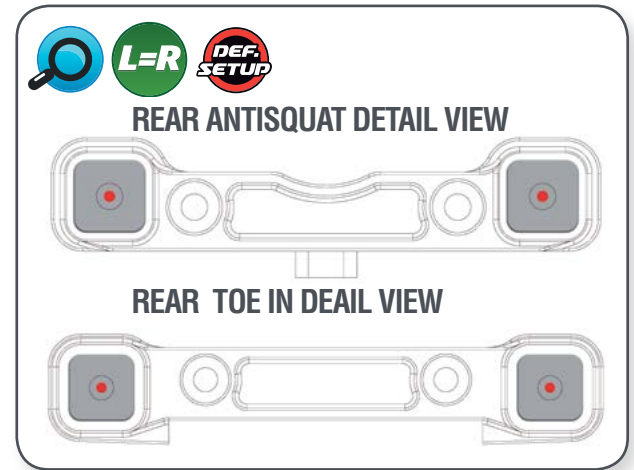
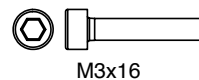

STEP 16

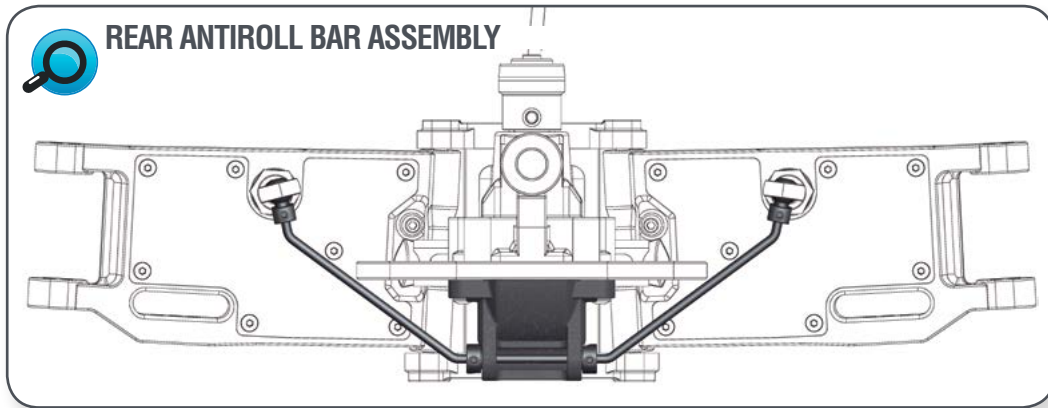
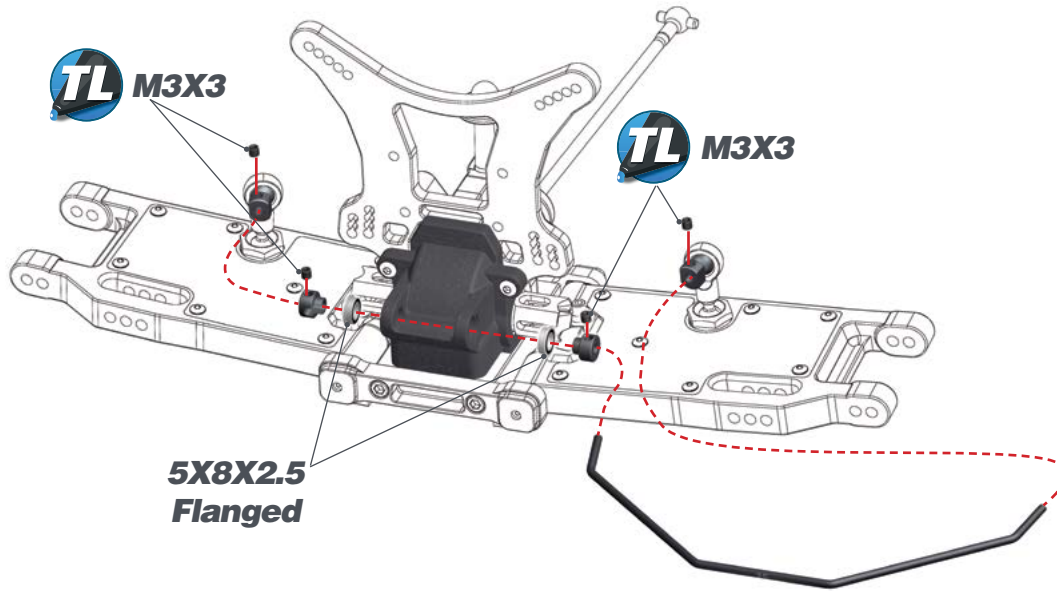

STEP 17

! Cutout supplied mud guards as illustrated following the trim lines. Make sure to place the holes in the mudguards as required

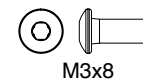
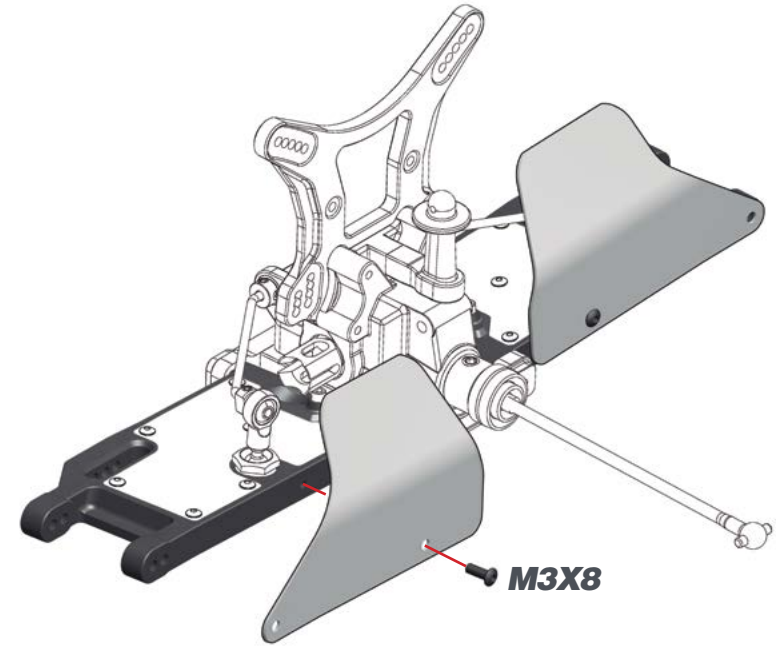

STEP 18

BAG 3

18.1

L=R

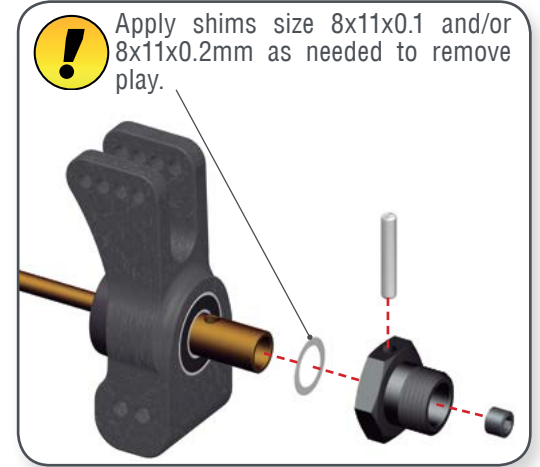
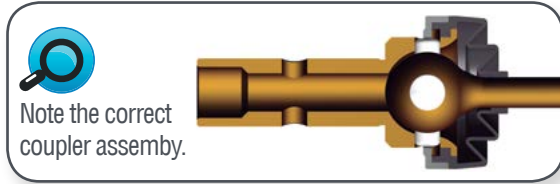
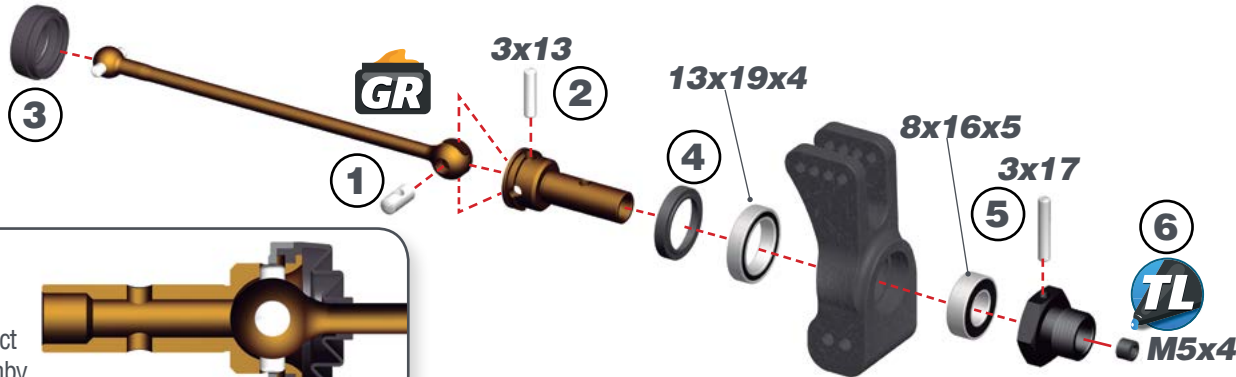

18.2

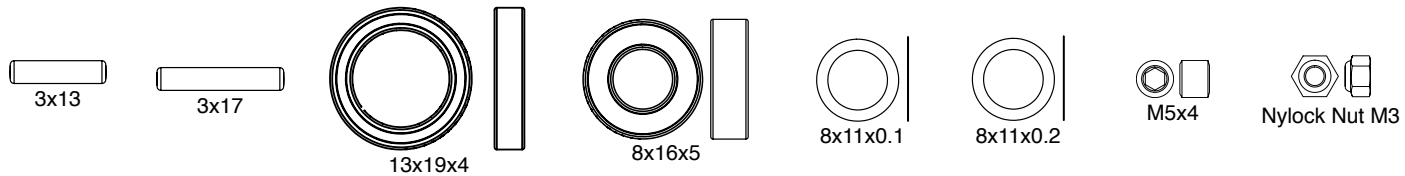
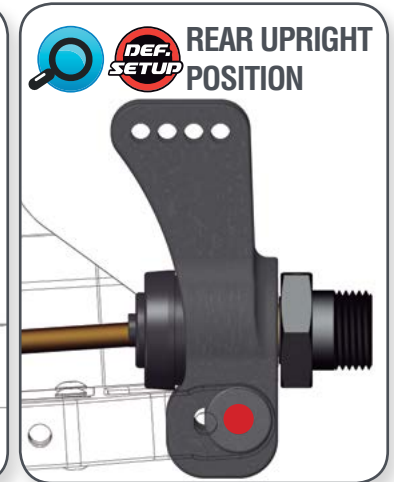
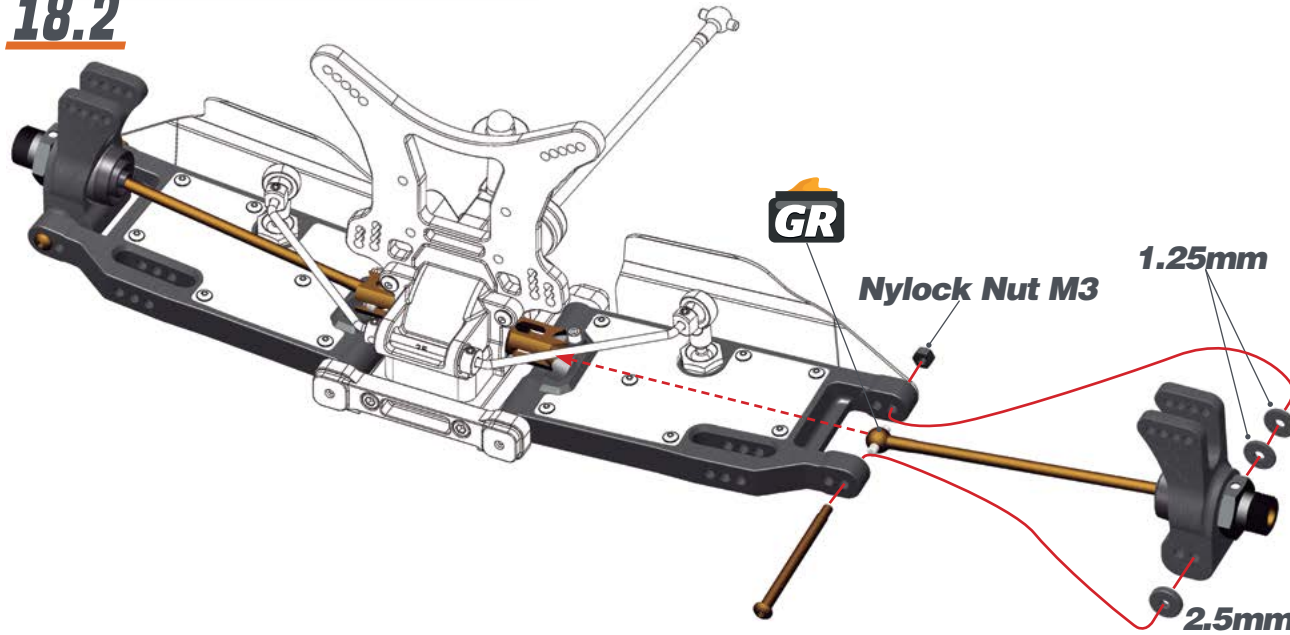

STEP 19

BAG 4

19.1

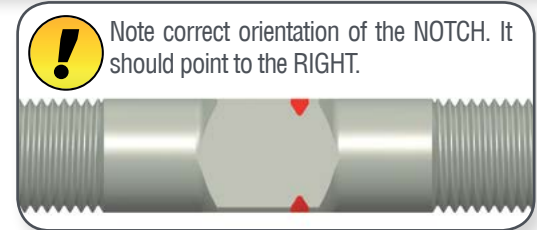
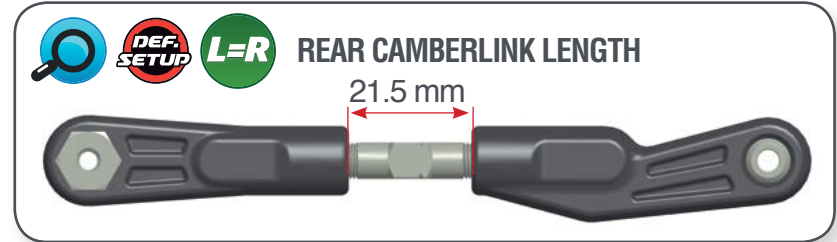
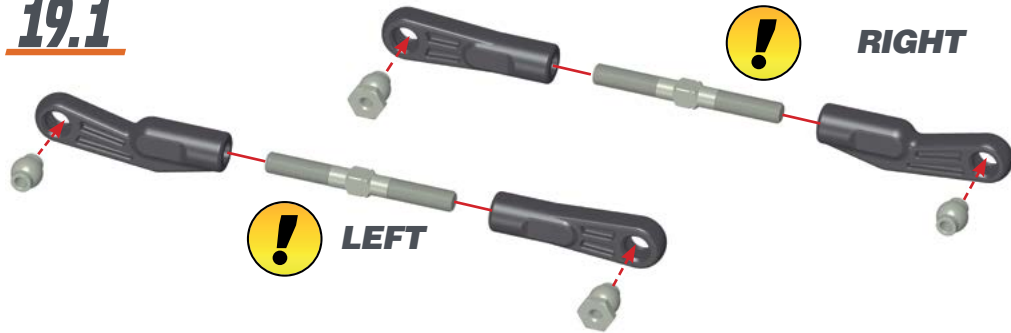

19.2

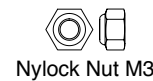
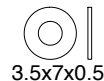
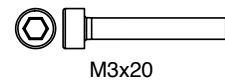
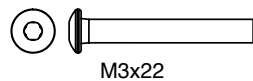
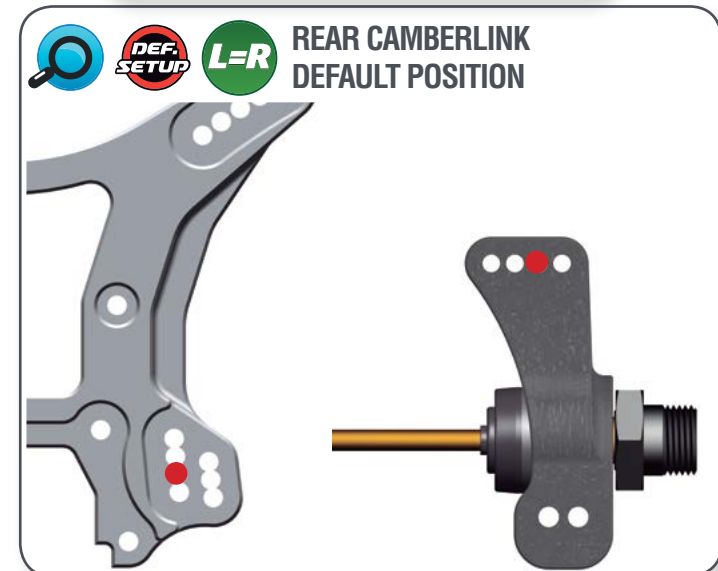
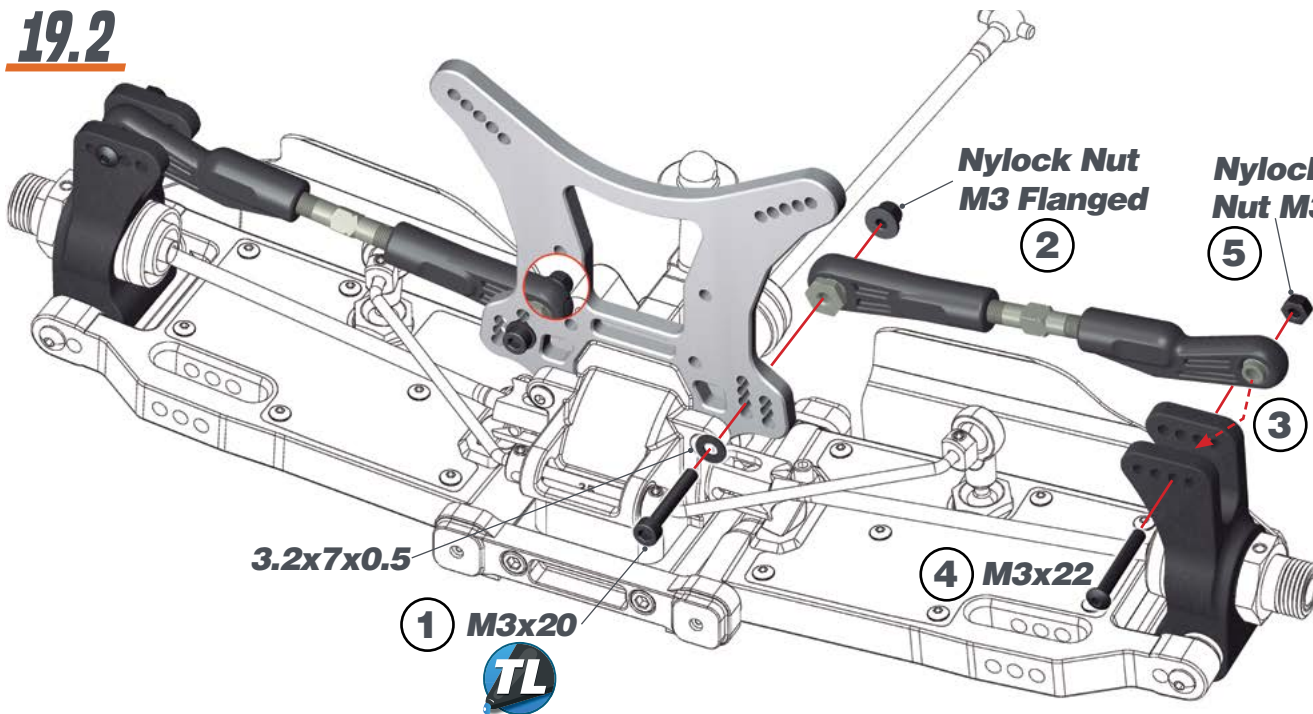

STEP 20

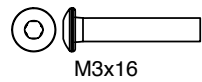
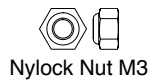
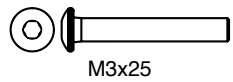
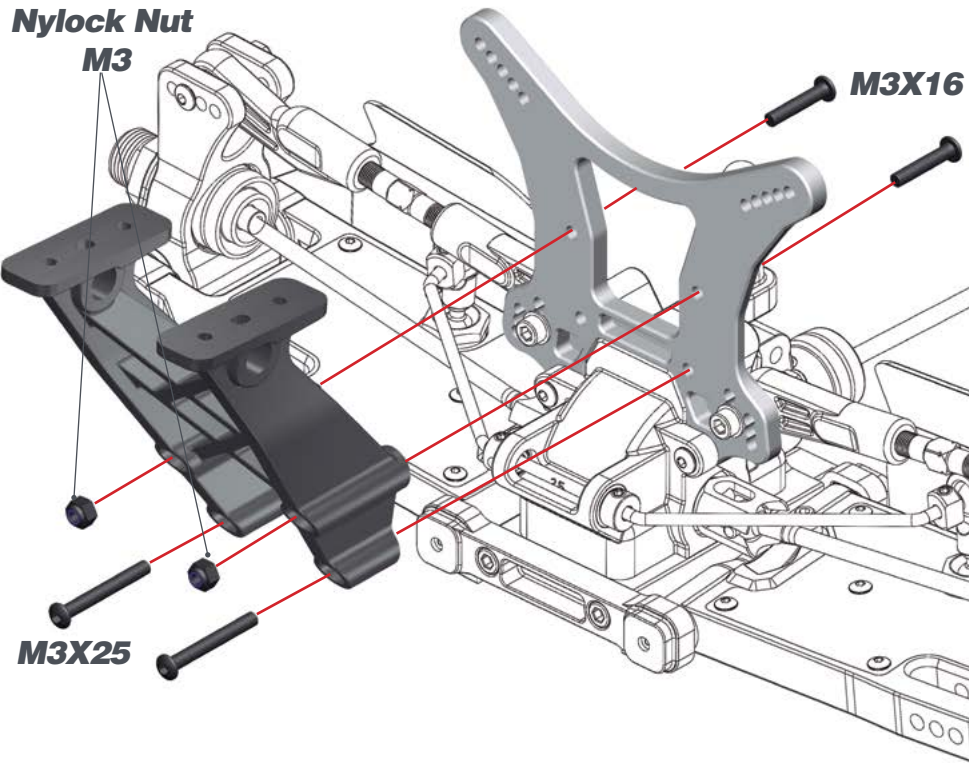

STEP 21

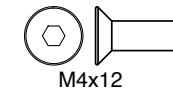
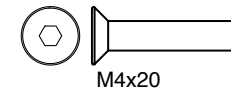
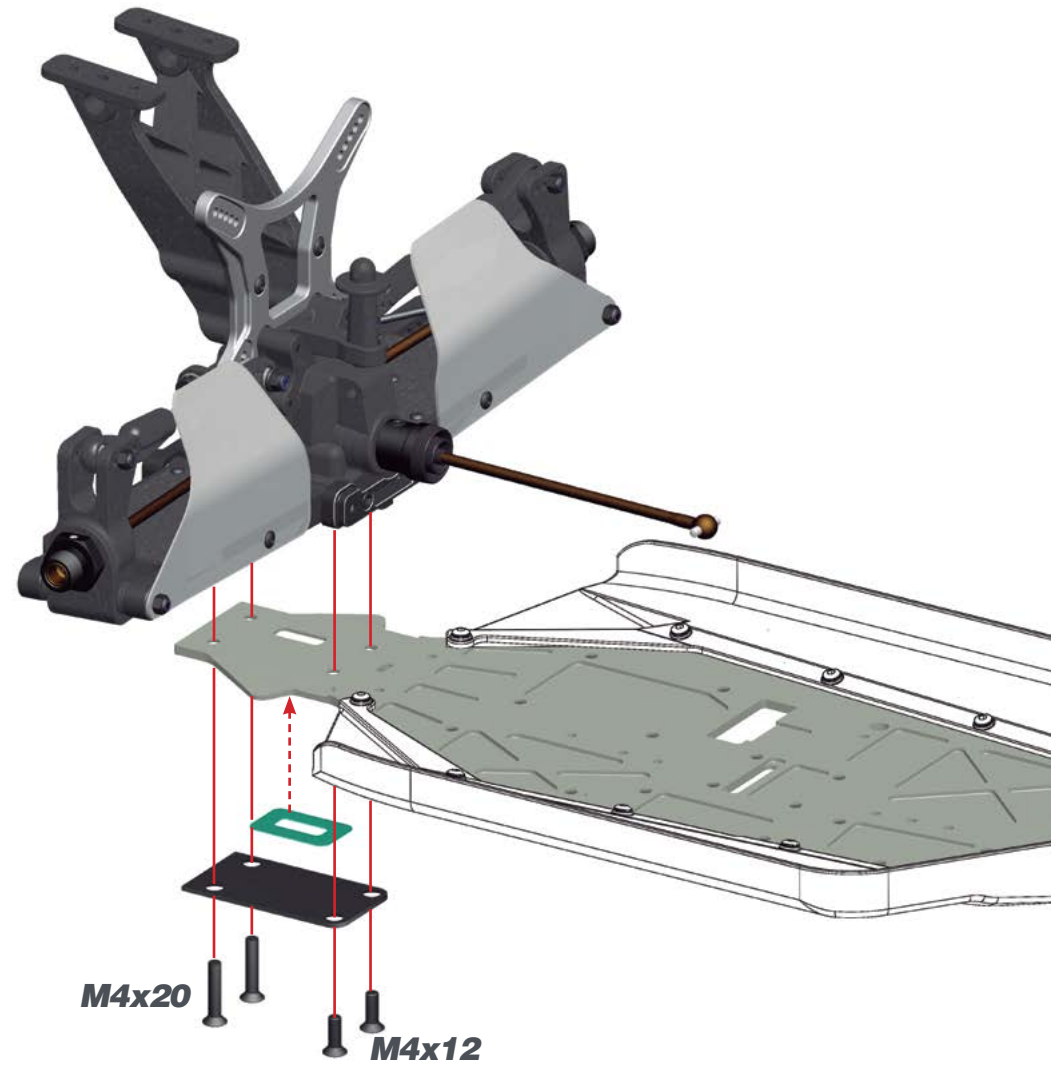

STEP 22

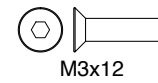
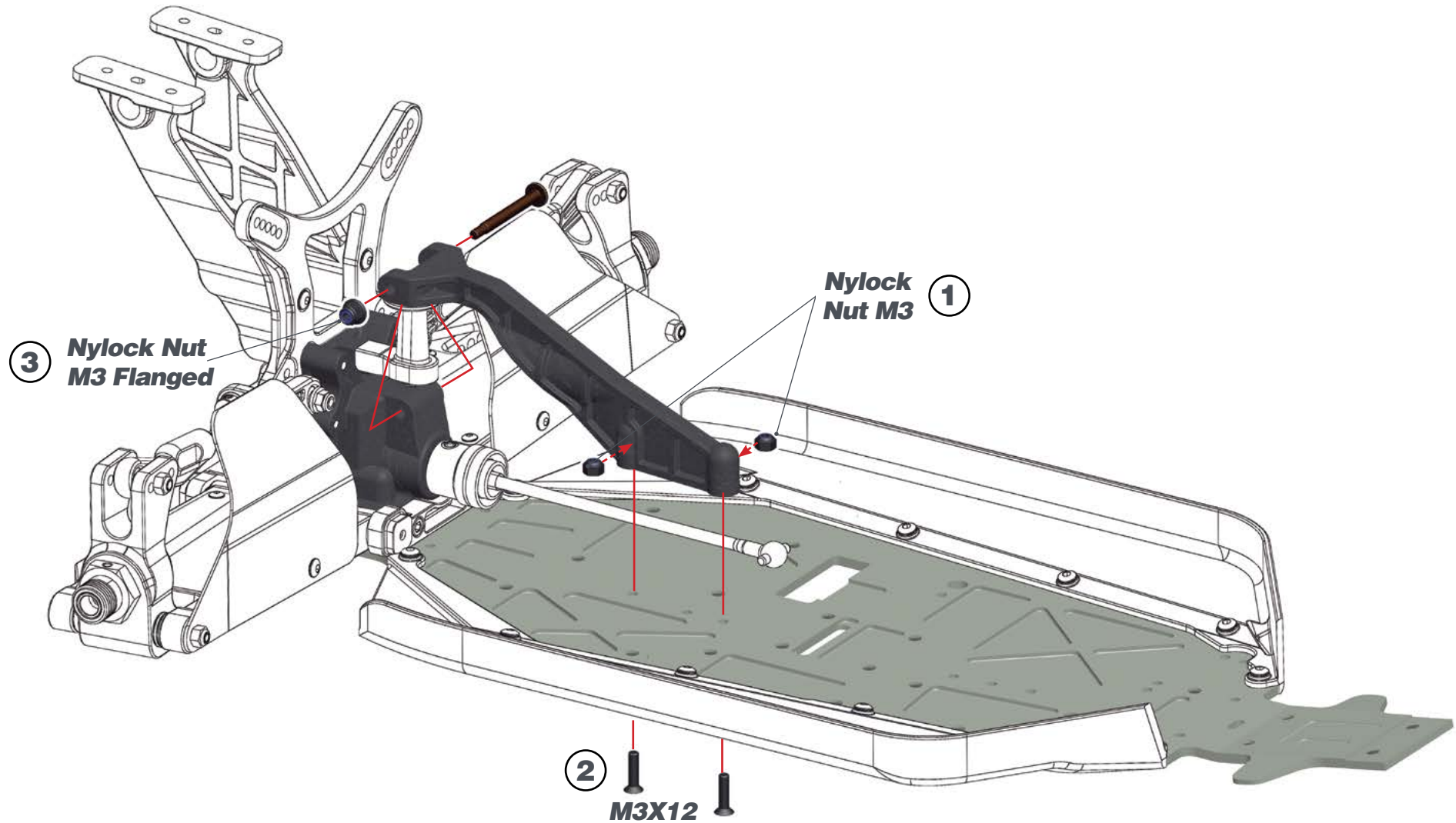

STEP 23 BAG 5

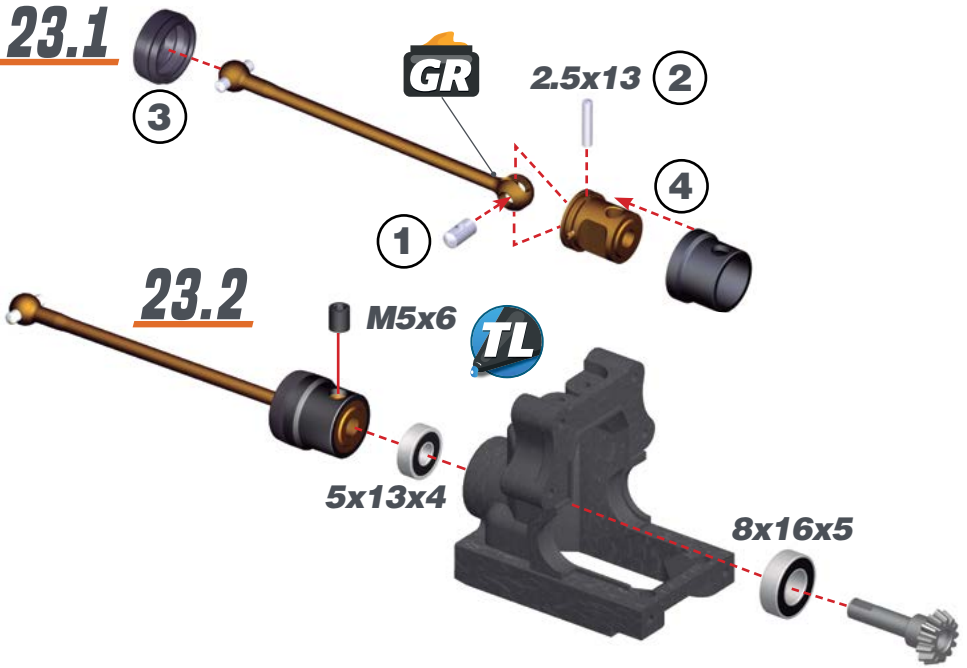

! After building the differential with new gears, new differential case and bearings, the diff may feel a little tight. The connected parts need at least an hour run-time to create a perfect match. Attention: When you assemble the diff with too much initial play, the gears will not run-in properly and may wear quickly. After 1 or 2 hours of running the car, re-check the gear-mesh between the ring gear and the pinion. All parts should have run-in properly now. You may add or remove 8x11x0.1 shims as needed.

STEP 24

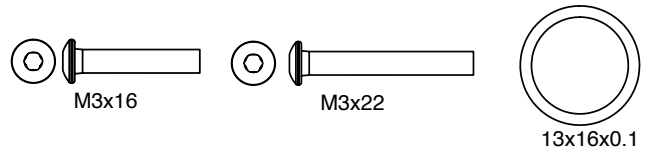
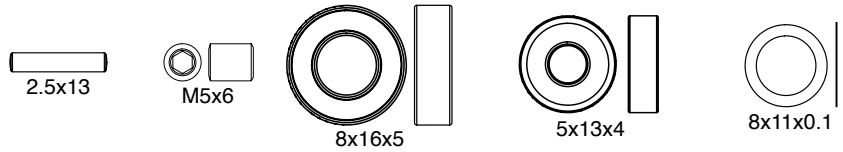
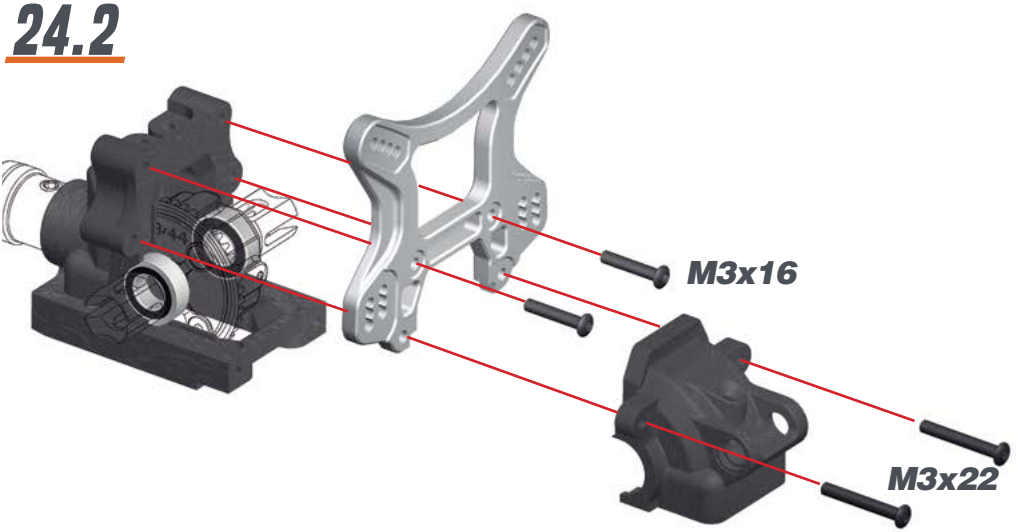

STEP 25

BAG 6

STEP 26

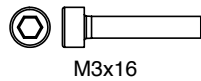
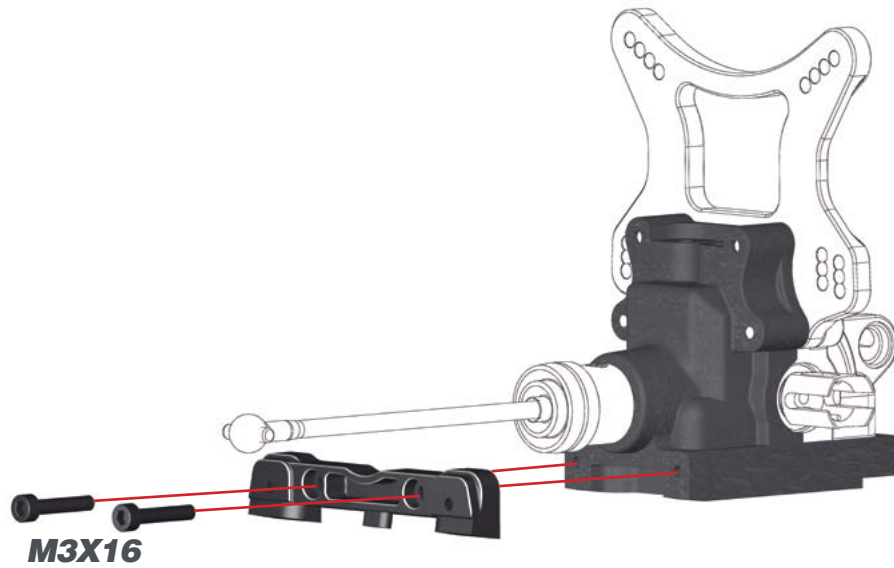

26.1

L=R



Tighten anti-roll bar cap until there is no play, and it moves freely.



26.2

L=R

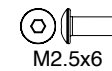
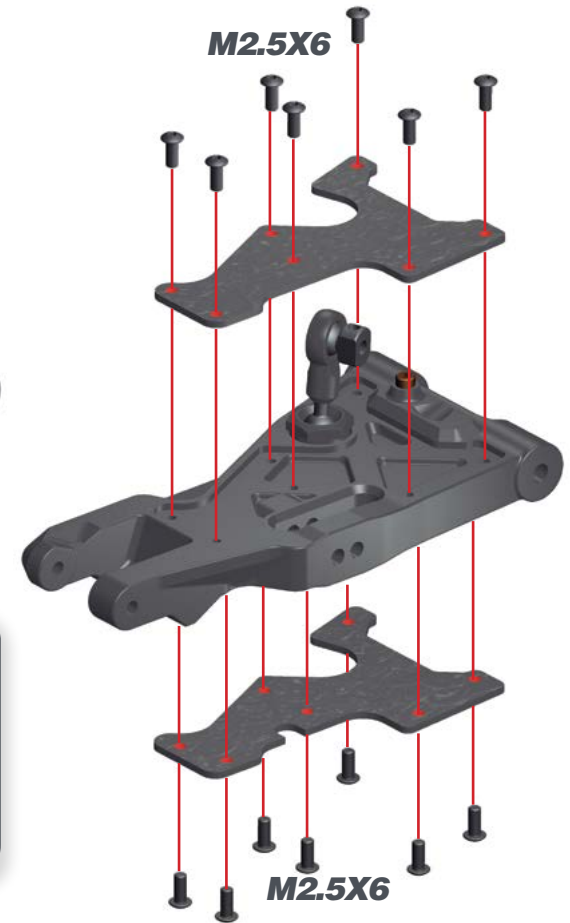

STEP 27

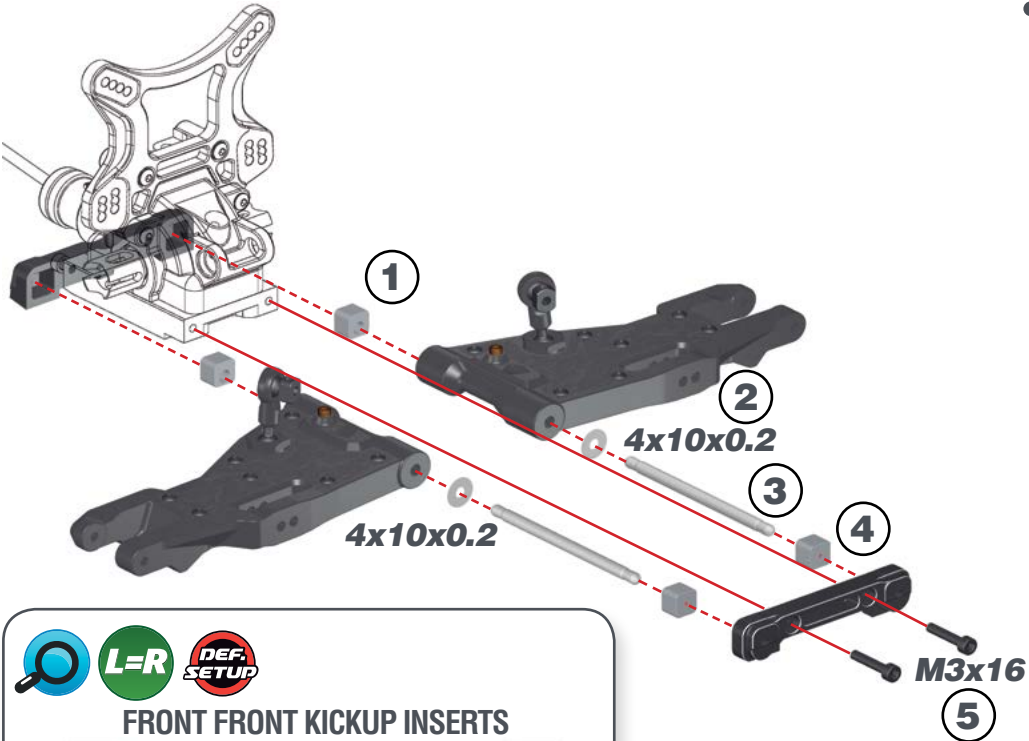

L=R **DEF. SETUP**

FRONT FRONT KICKUP INSERTS

FRONT REAR KICKUP INSERTS

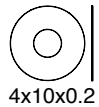
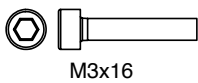

STEP 28

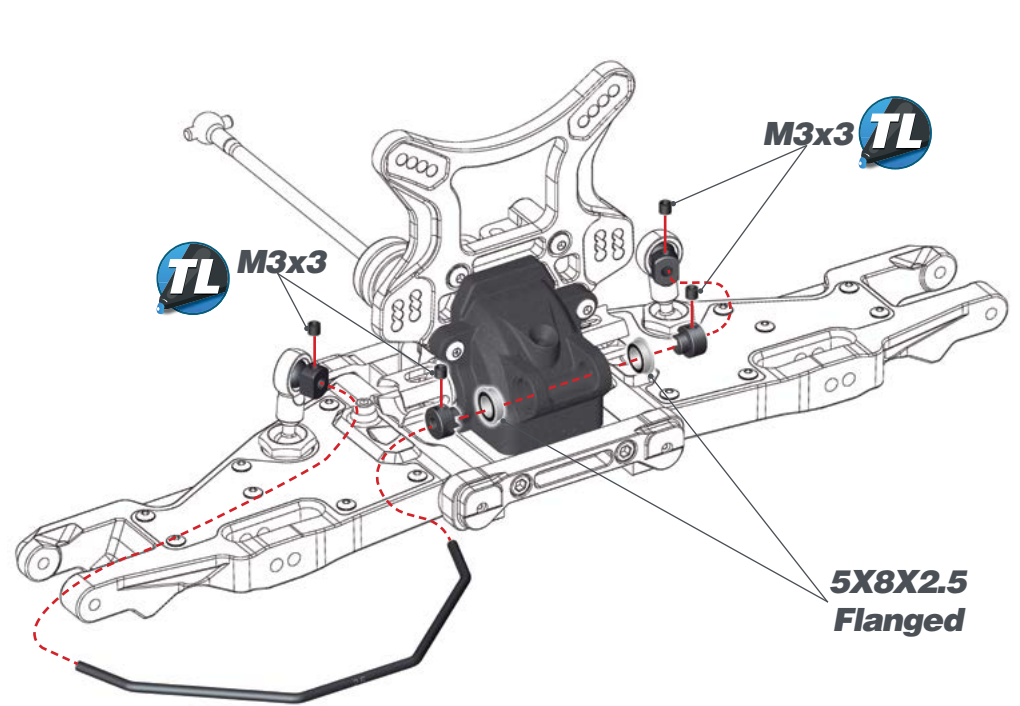

FRONT ANTIROLL BAR ASSEMBLY



STEP 29

BAG 7

29.1 L=R

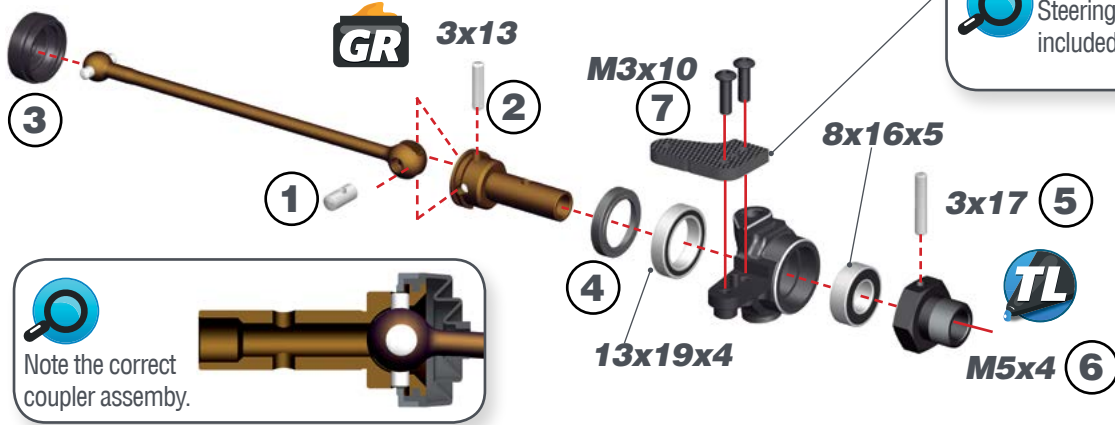

STEERING ARMS
Steering arm 1 is included in the kit.

! Apply shims size 8x11x0.1 and/or 8x11x0.2mm as needed to remove play.

29.2 L=R

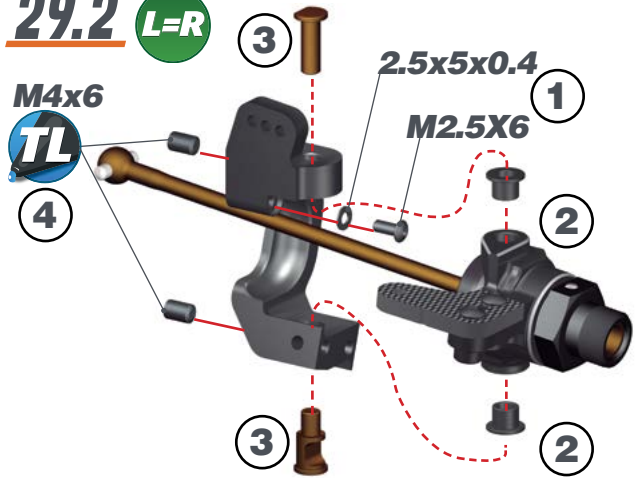

! Align the flat spot on the shaft with the grub screw.

29.3

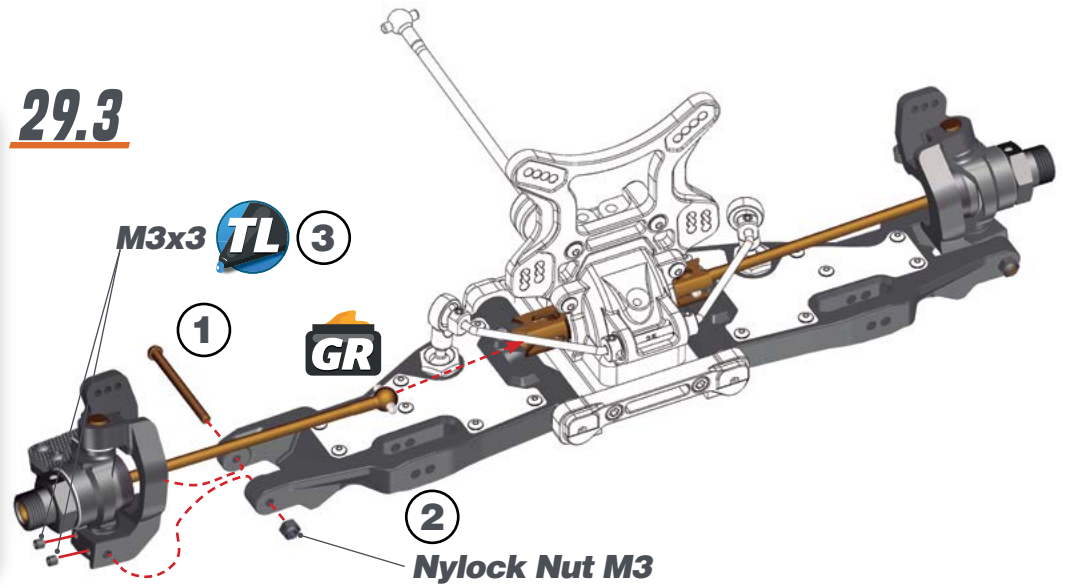

- 3x13
- 13x19x4
- 8x16x5
- 8x11x0.1
- 8x11x0.2
- 3x17
- M5x4
- M3x10
- M2.5x6
- 2.5x5x0.4
- M4x6
- M3x3
- Nylock Nut M3

STEP 30

BAG 8

30.1

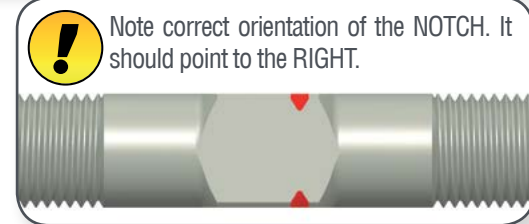
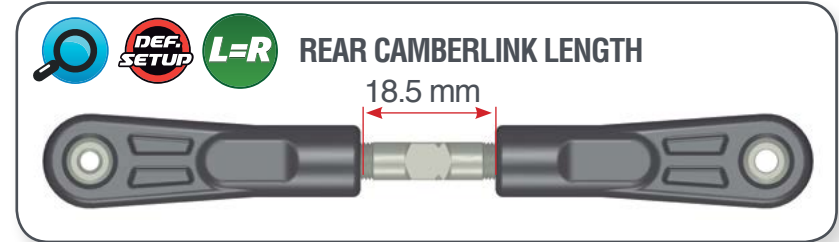
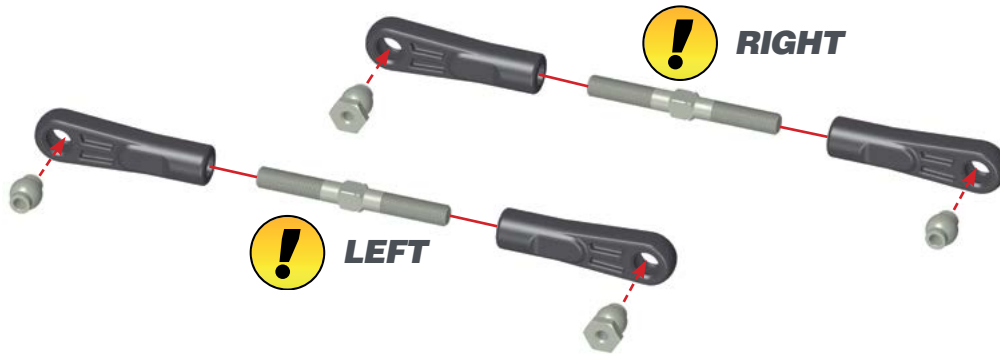

30.2

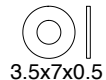
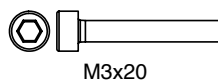
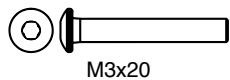
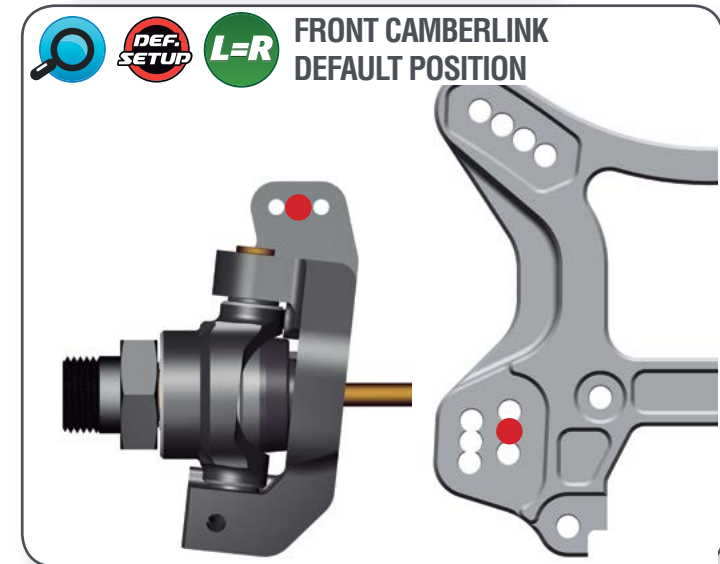
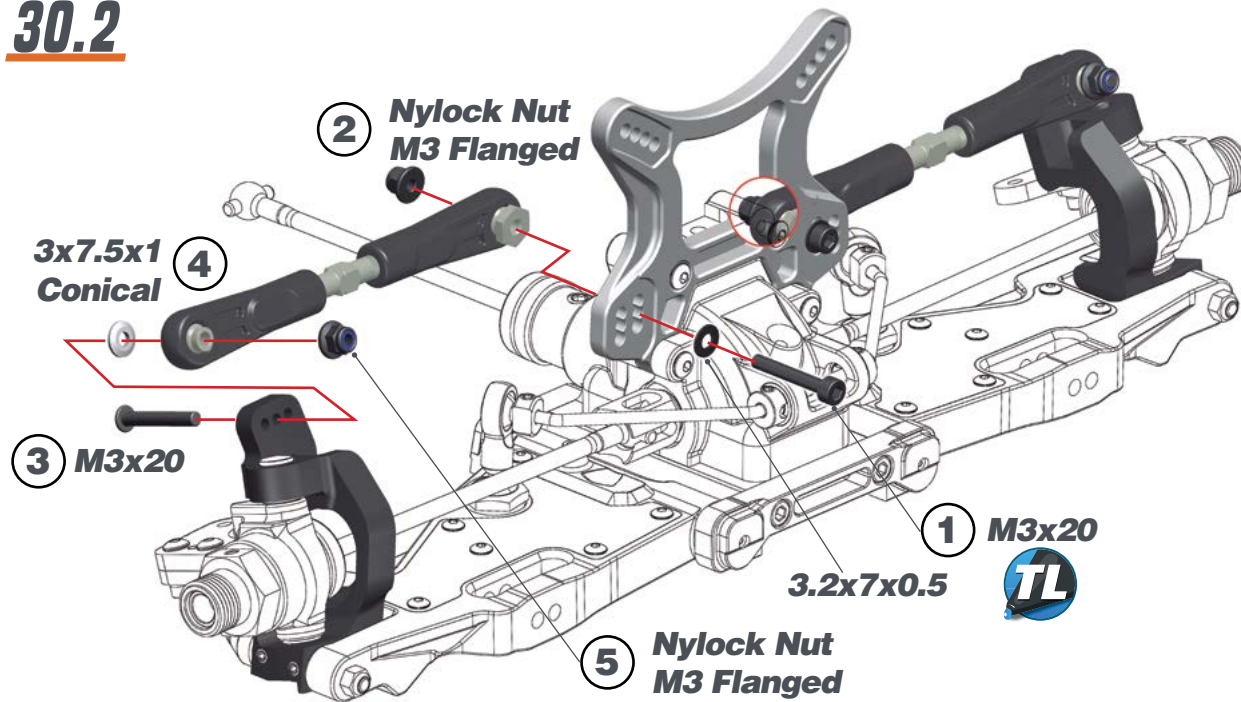

STEP 31

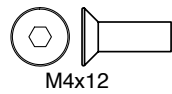
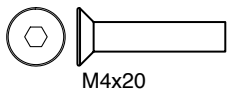
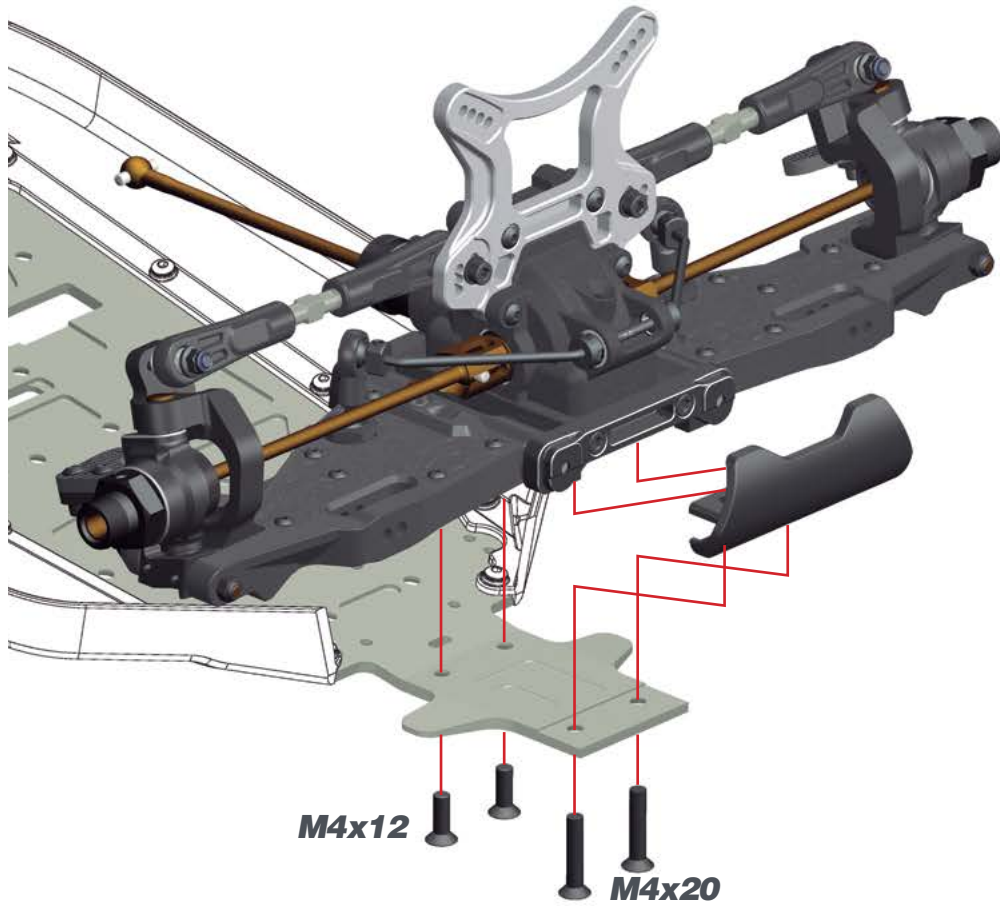

STEP 32

32.1

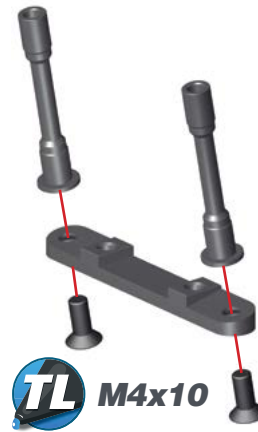

32.2

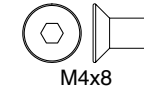
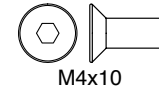
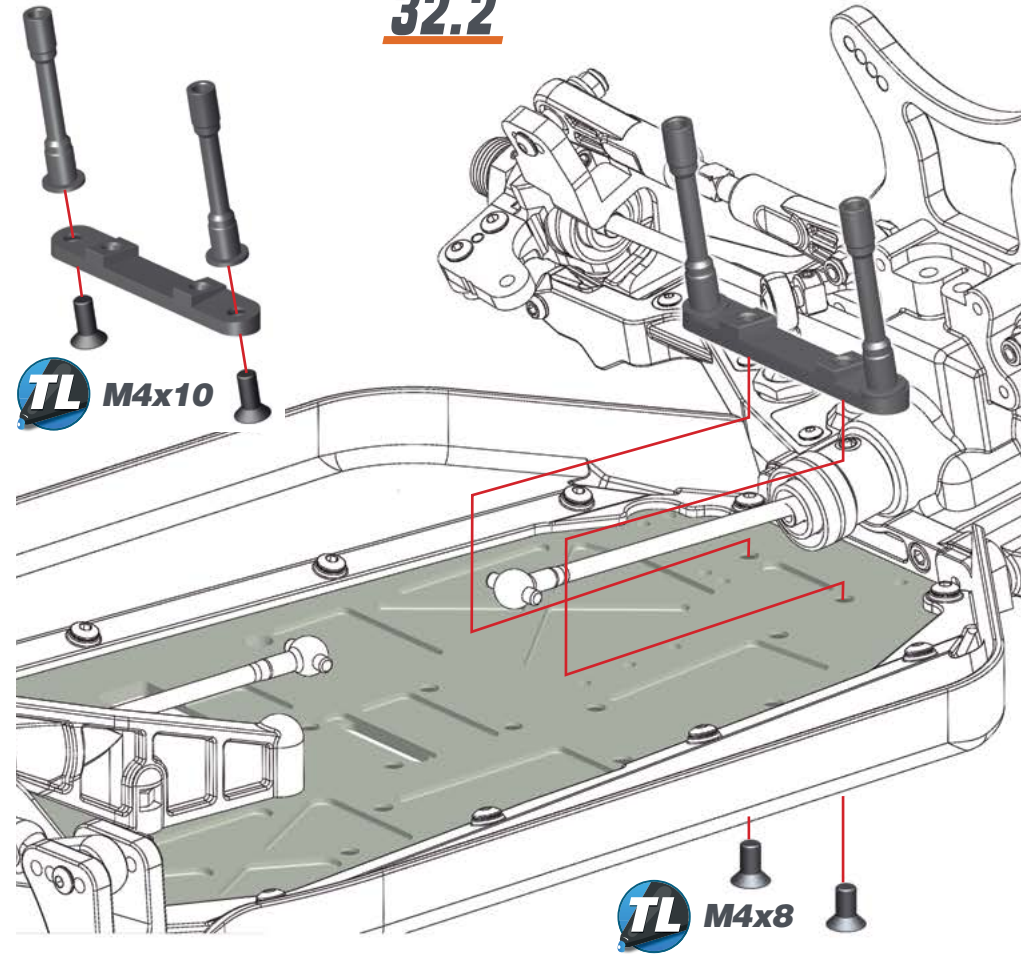

STEP 33 BAG 9

33.1



M2x10

33.2

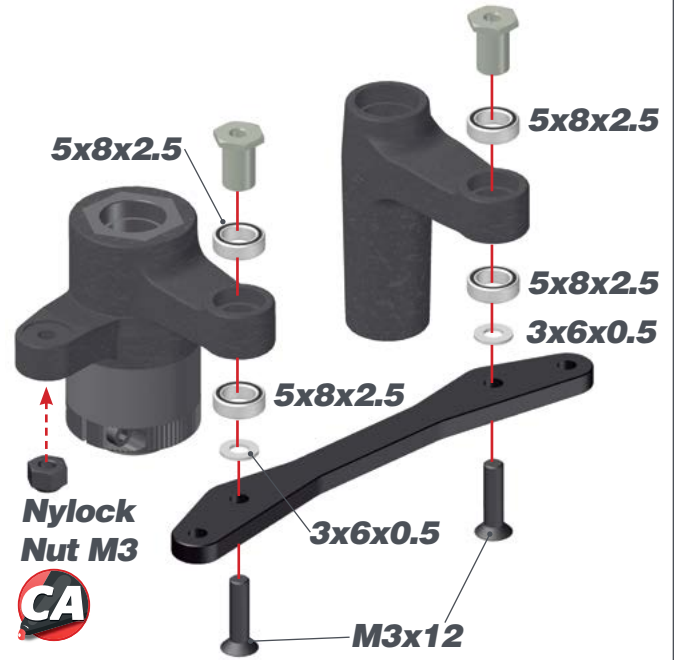

Nylock Nut M3

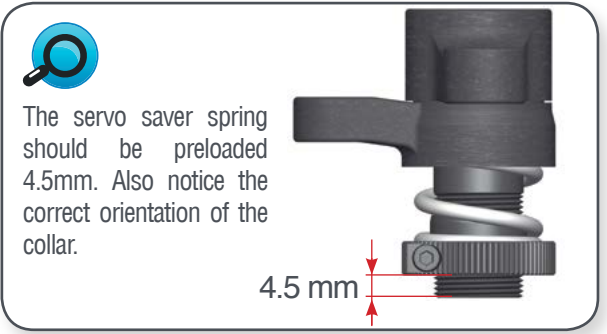

The servo saver spring should be preloaded 4.5mm. Also notice the correct orientation of the collar.

4.5 mm

STEP 34

34.1

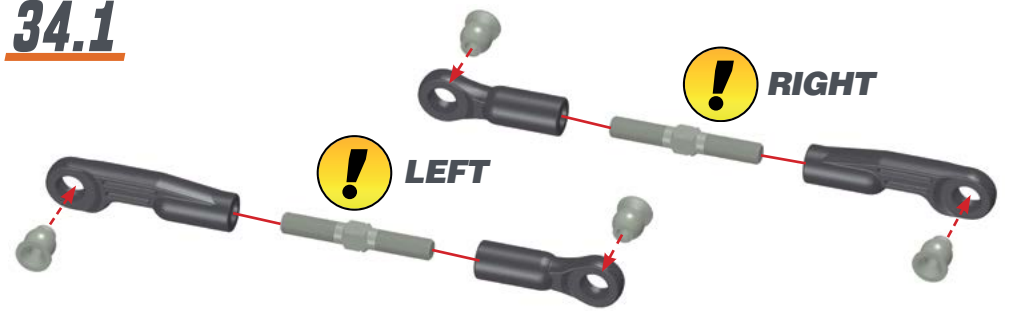

! LEFT

! RIGHT

STEERING TRACKROD LENGTH

8.5 mm



34.2

Nylock Nut M3 Flanged

3x7.5x1
3x7.5x1
Conical

M3x20

3x7.5x1

3x7.5x1
Conical

M3x20



! Note correct position of the conical shim.

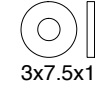
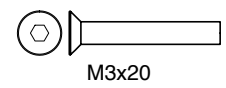
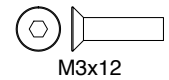
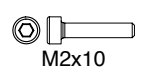

STEP 35

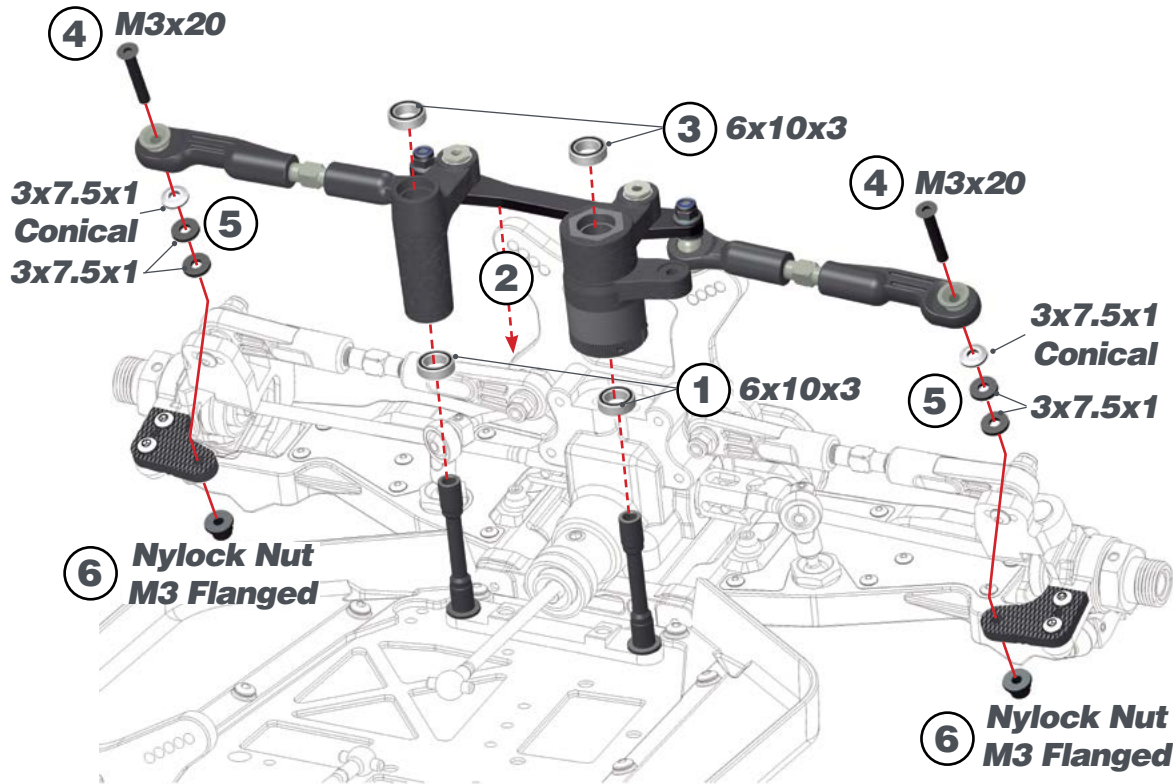

STEP 36

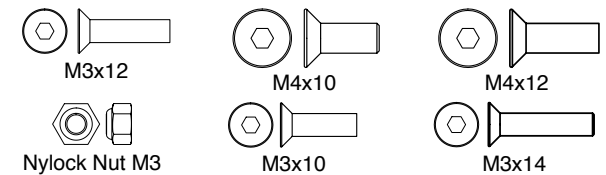
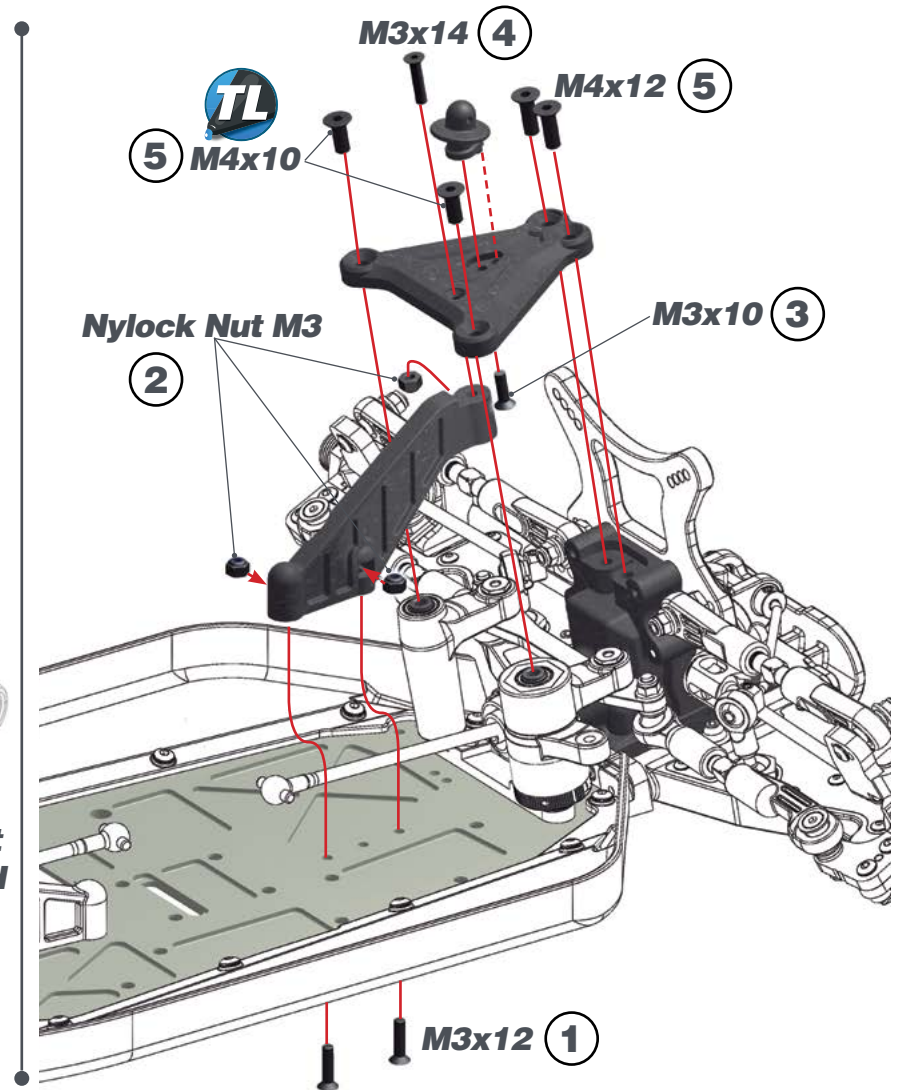

STEP 37

BAG 10

37.1

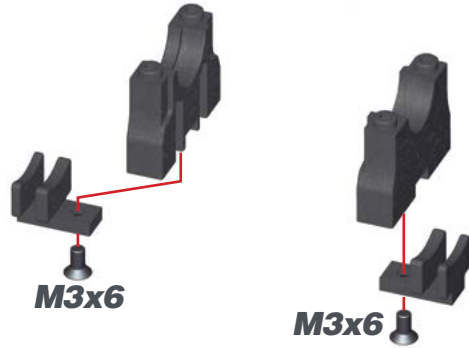

37.2

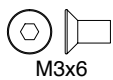
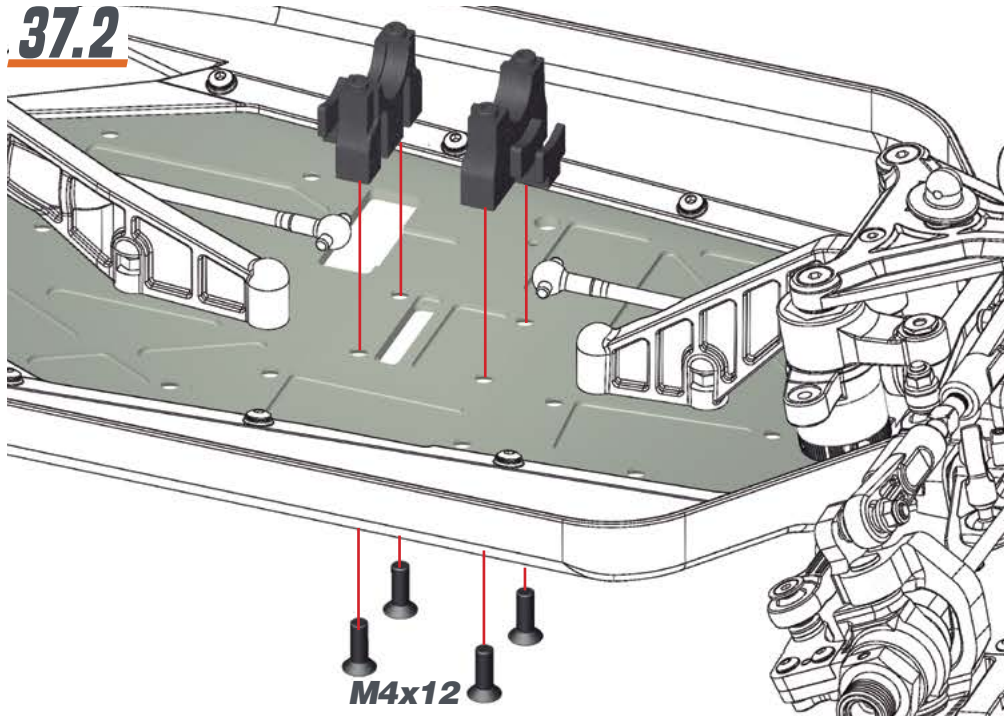

M3x6



M4x12

STEP 38

38.1

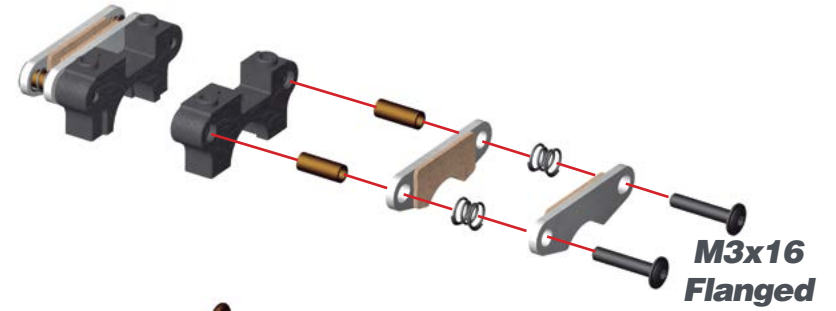

M3x16
Flanged

38.2



Nylock nut M3
3.2x7x0.5

M3x10

38.3

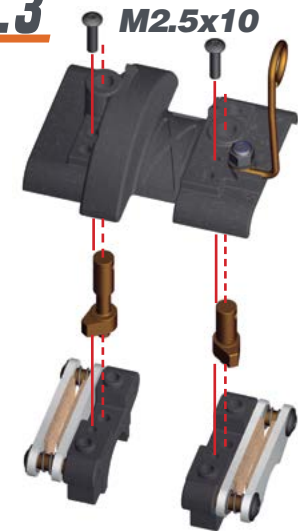

M2.5x10

38.4

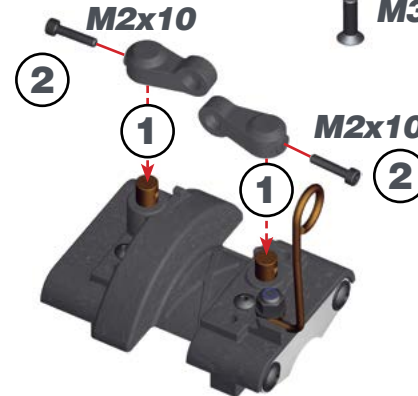

M2x10

M2x10

M3x10

2

1

1

2



M3x16 Flanged



M3x10

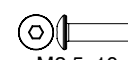

M2.5x10



Nylock Nut M3



M2x10



3.5x7x0.5

STEP 39

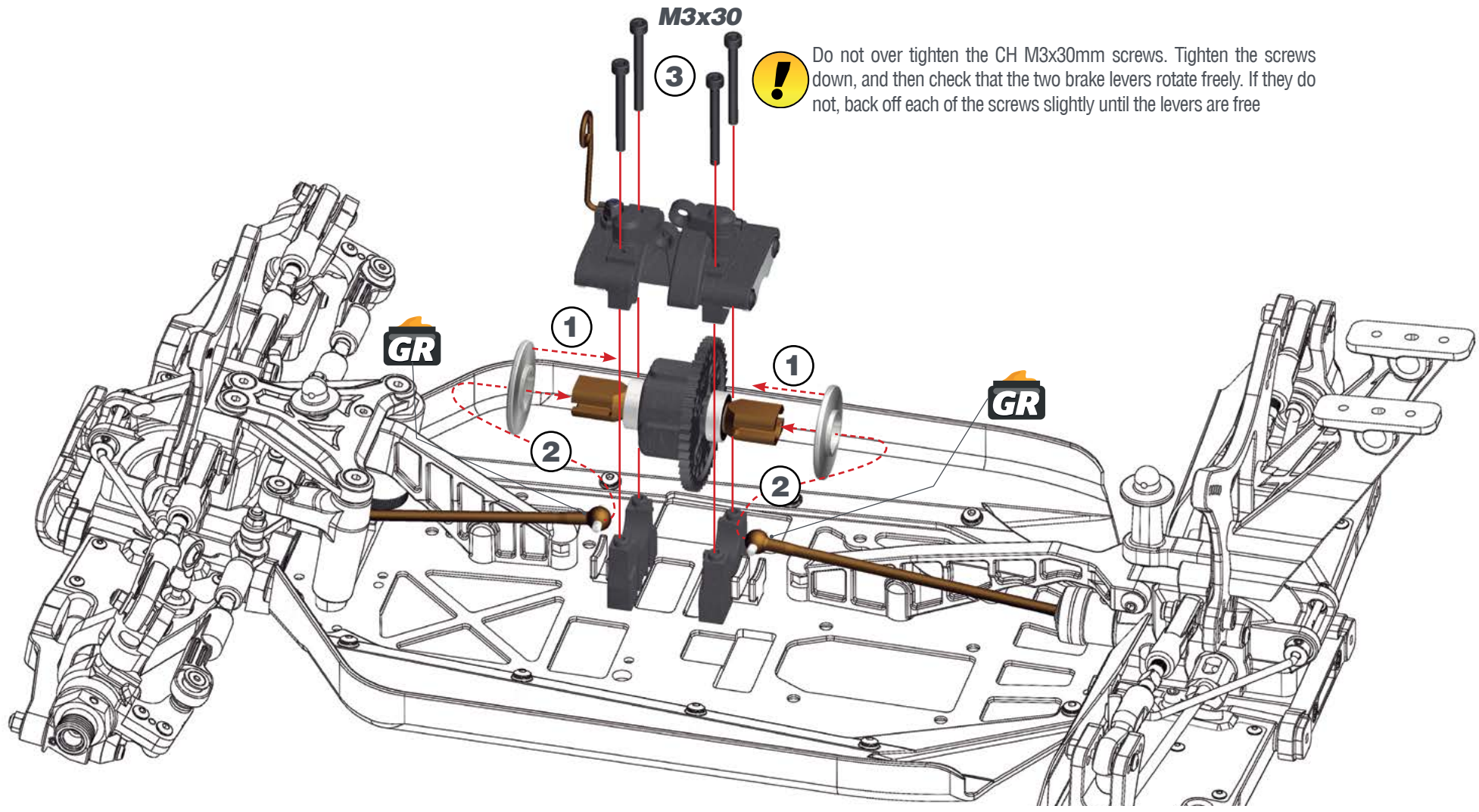

Do not over tighten the CH M3x30mm screws. Tighten the screws down, and then check that the two brake levers rotate freely. If they do not, back off each of the screws slightly until the levers are free

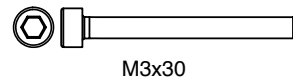

STEP 40 BAG 11

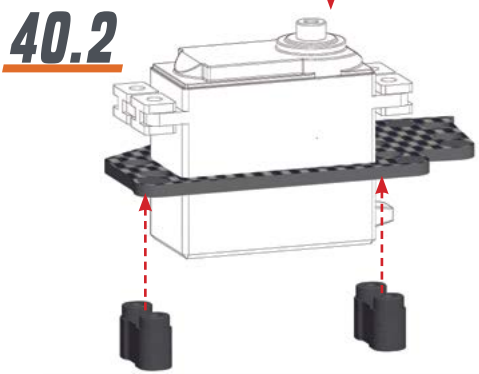
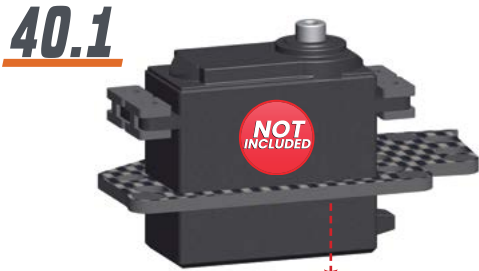

! Using the supplied eccentric servo mounts. Choose the closest combination of mounts to achieve your servos mounting distance."

49.5mm	49mm	48.5mm
48mm	47.5mm	

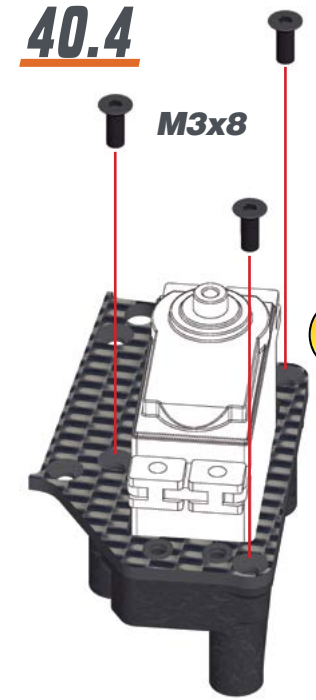
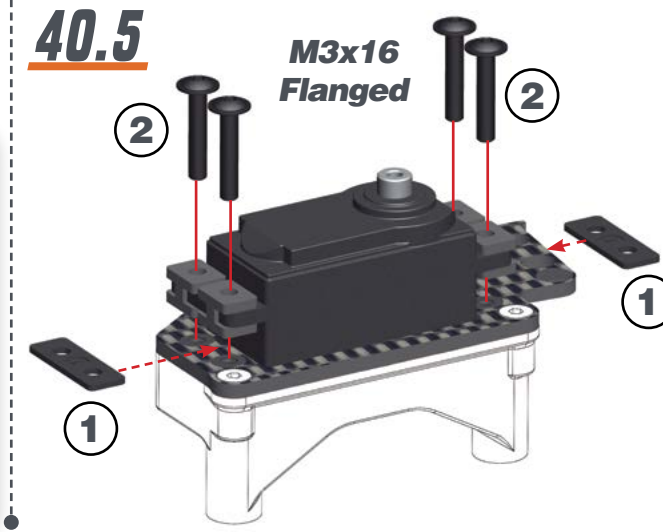

! Pull the servo up and then install the M3x8.

! **SERVO SPACERS**

The servo must not be below the bottom legs of the radio box/servo mount. Use enough plastic shims in the step 40.5 to ensure that point.

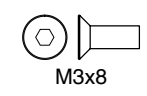
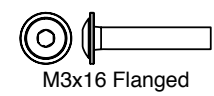

STEP 41

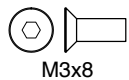
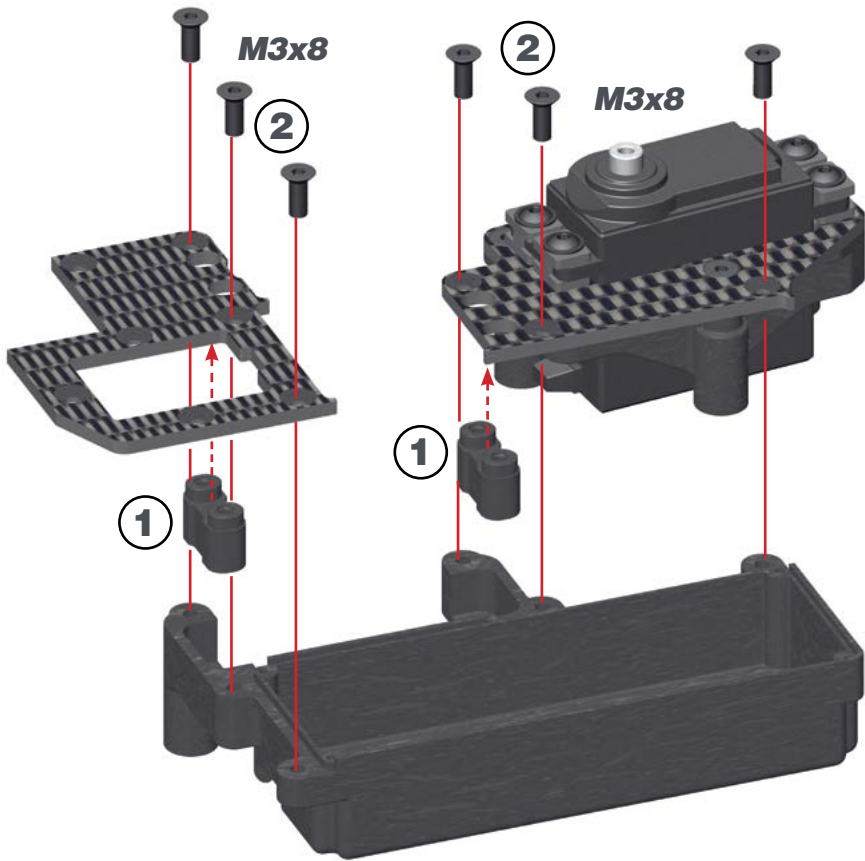

STEP 42

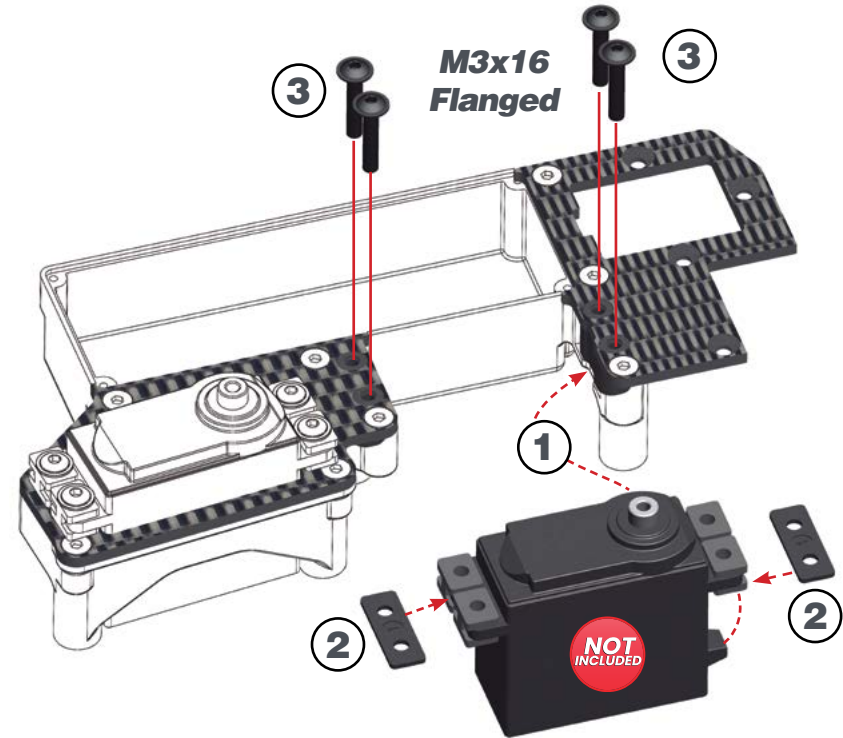

SERVO SPACERS

The servo should not be below the bottom legs of the radio box/servo mount.

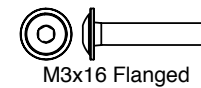
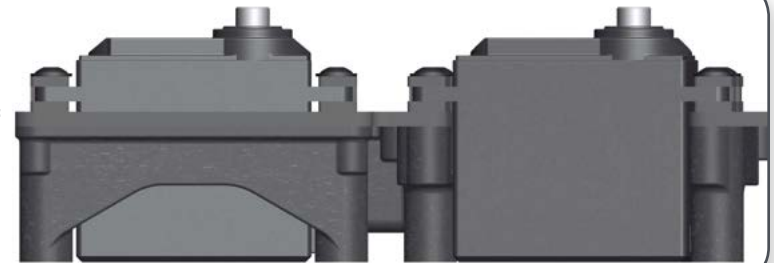

STEP 43

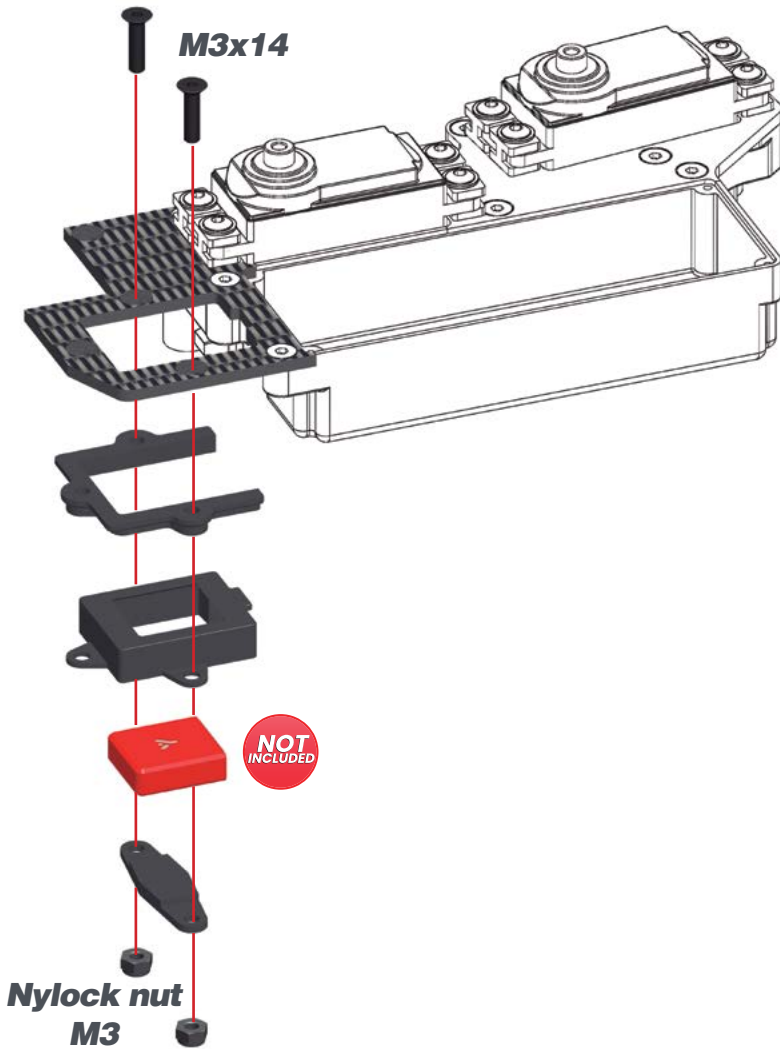

STEP 44

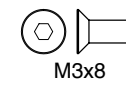
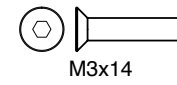
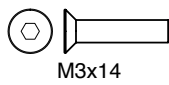
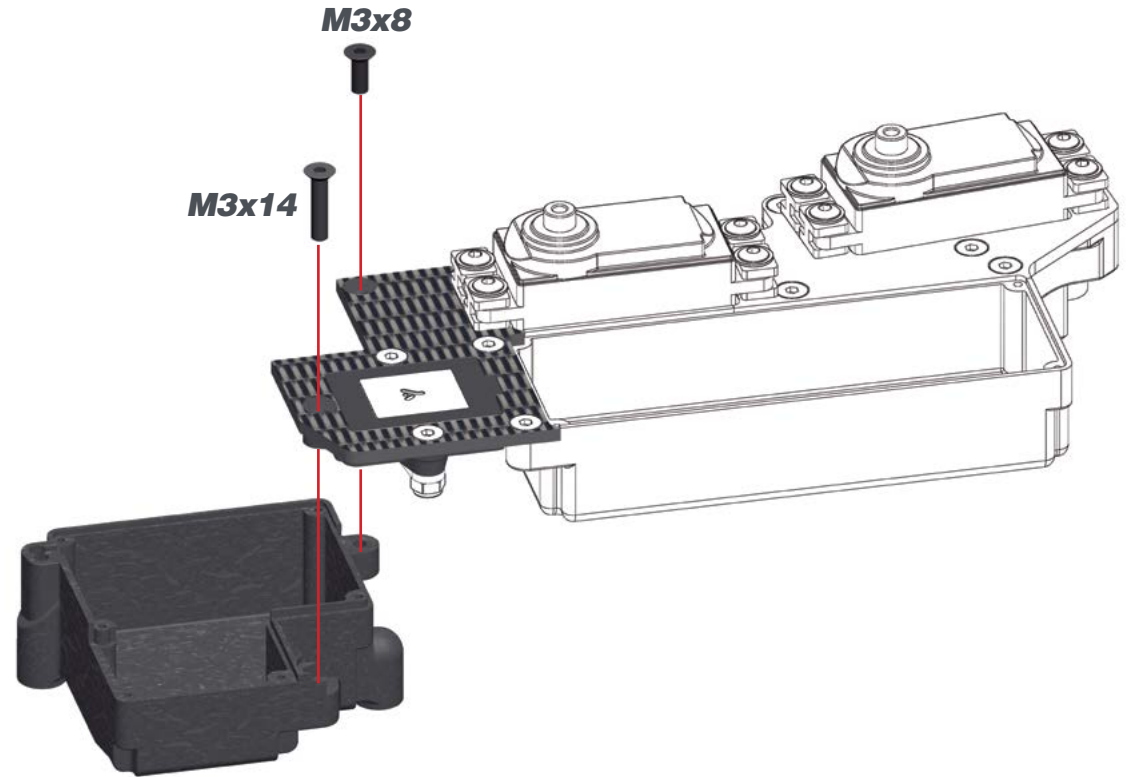

STEP 45

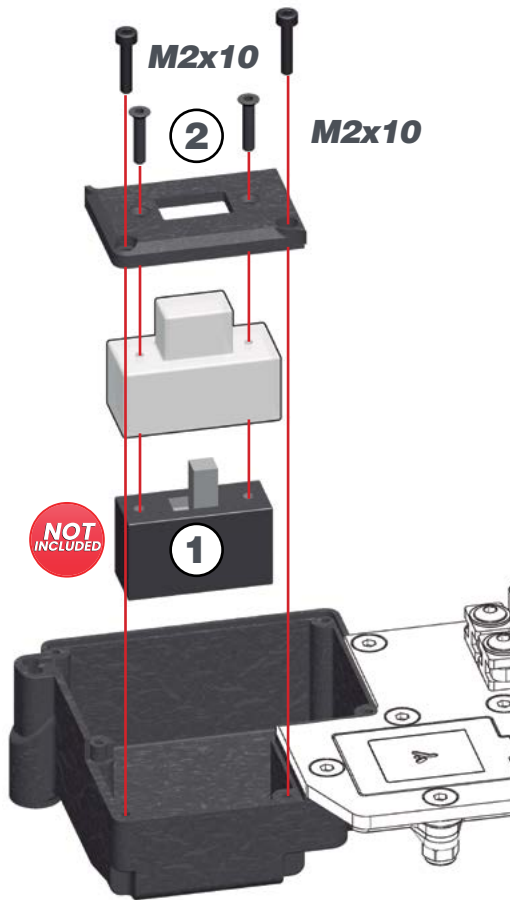

STEP 46

46.1

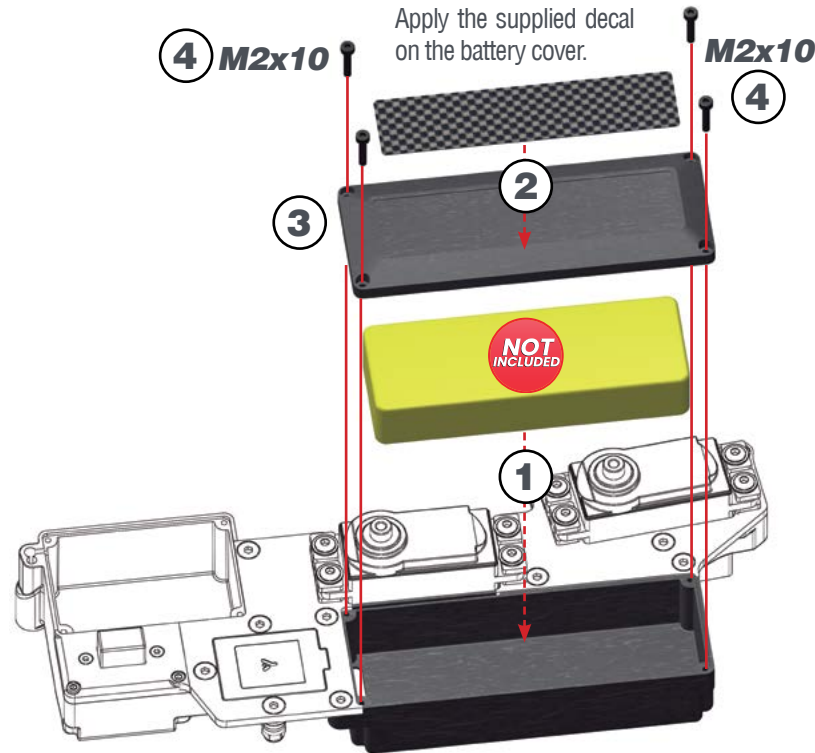

46.2

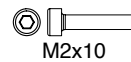
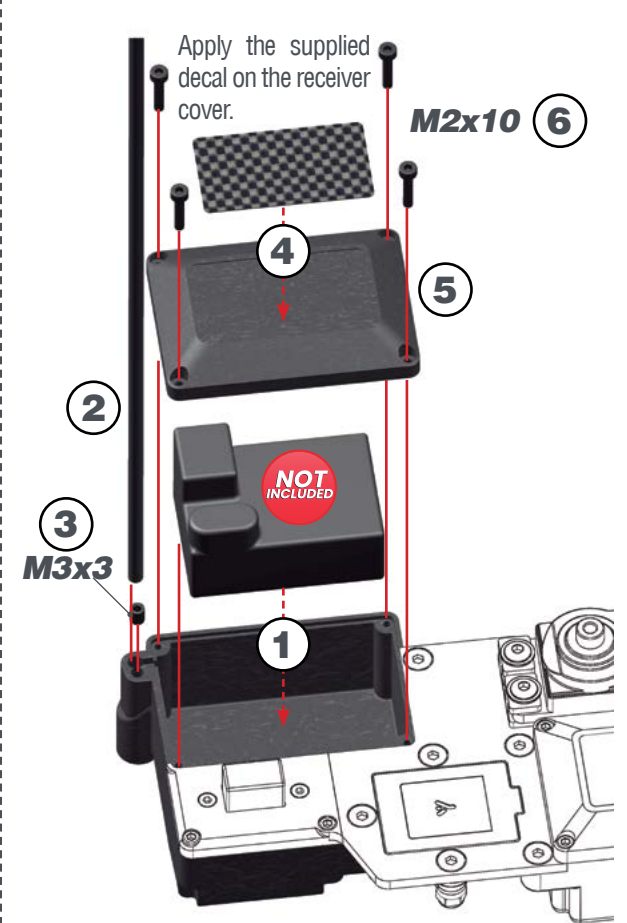

STEP 47

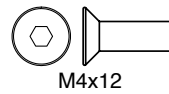
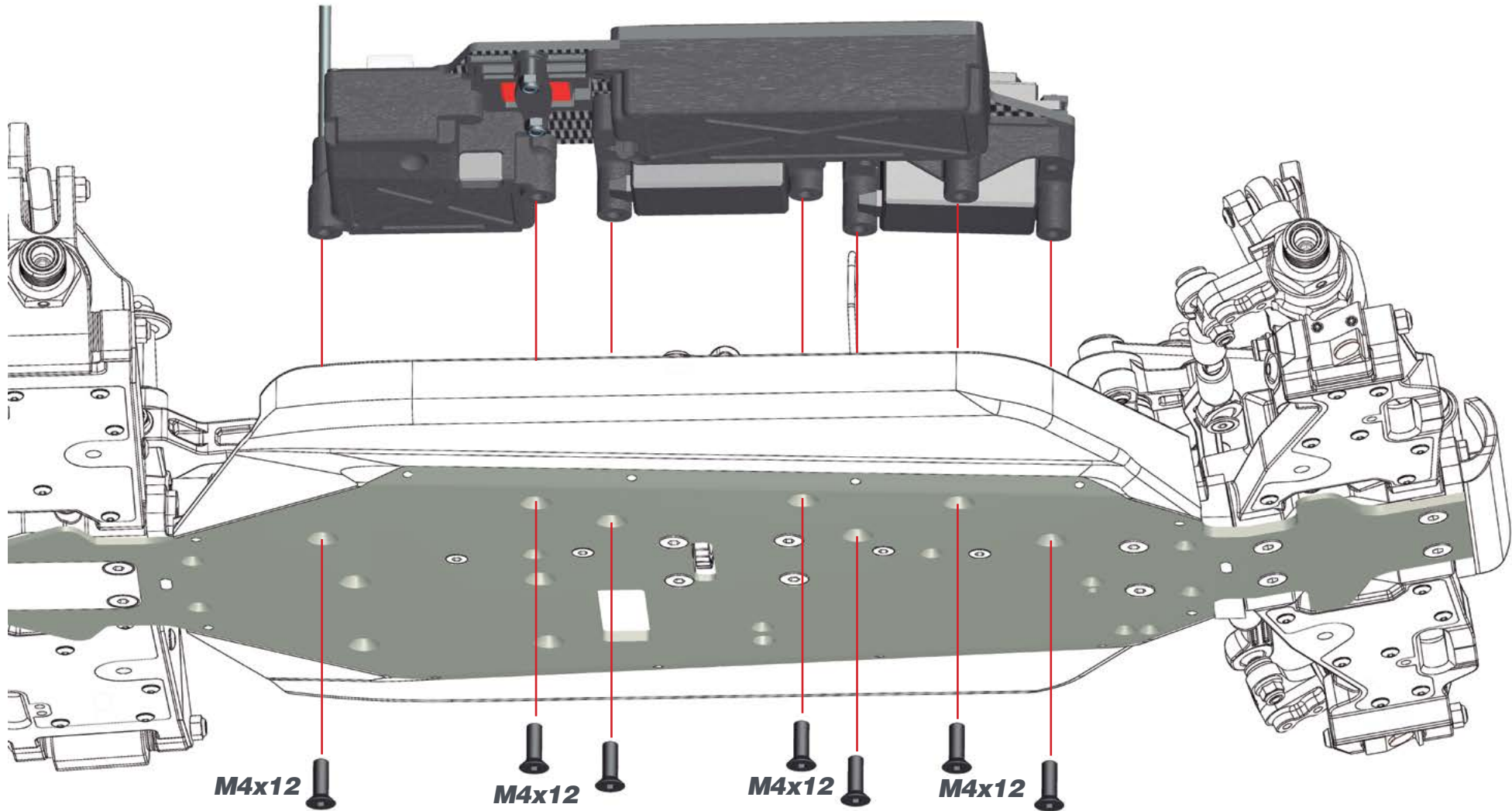

STEP 48

48.1



STEERING LINK LENGTH

Between different servo brands there could be slight differences.

11.8 - 12.2 mm



48.2

Nylock Nut M3



Check how many teeth your servo spline has (23, 24 or 25) and use the right lever.

3x7.5x1 Conical

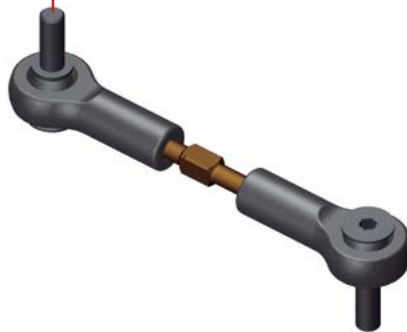

Note correct position of the conical shim.



3x7.5x1 Conical



Nylock Nut M3

48.3

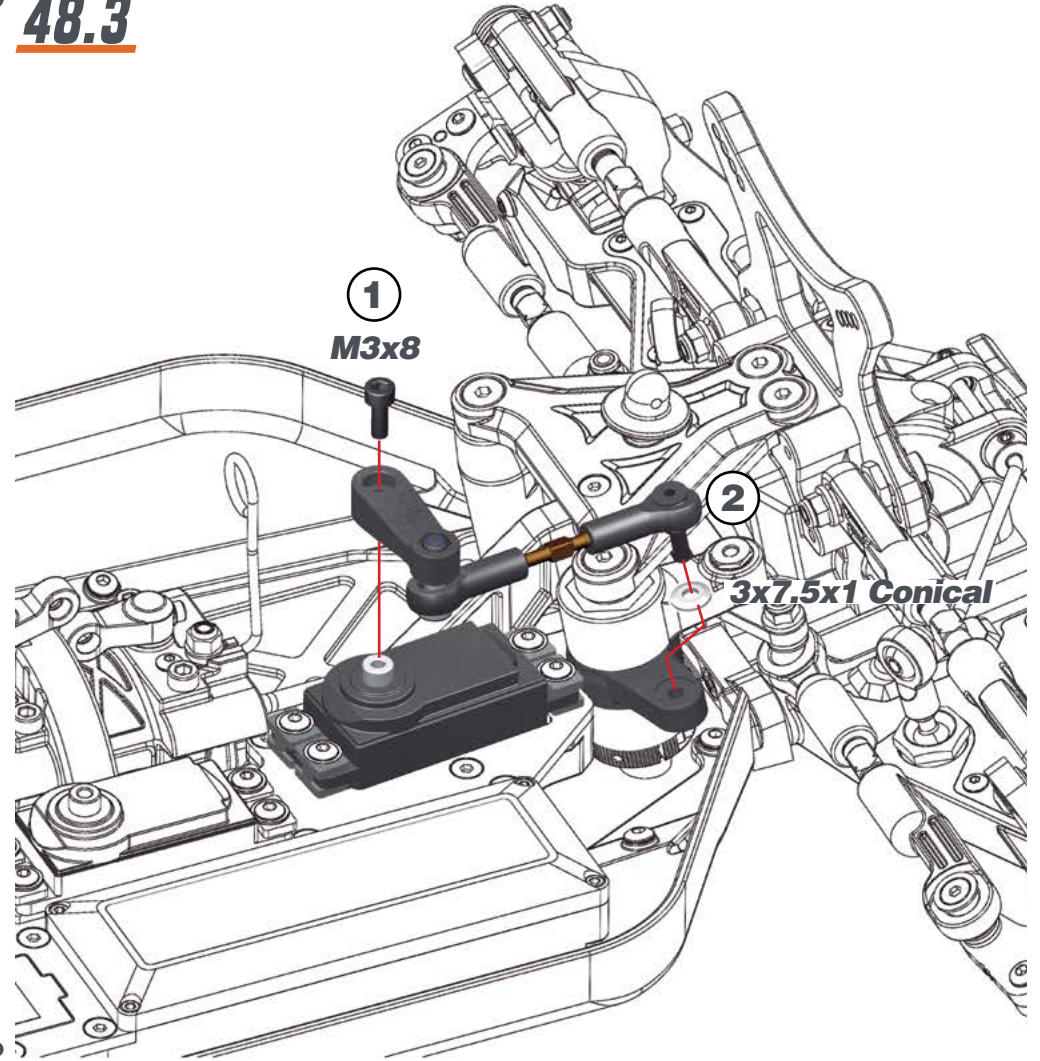

1

M3x8

2

3x7.5x1 Conical



M3x8



3x7.5x1 Conical

STEP 49

STEP 50

THROTTLE / BRAKE SPOKE LENGTHS

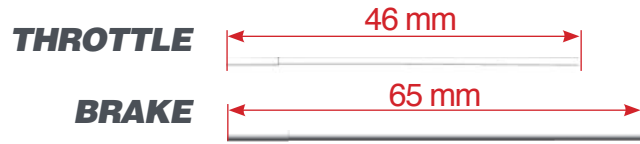

THROTTLE / BRAKE ASSEMBLY

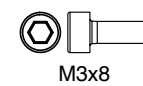
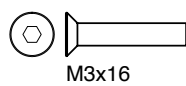
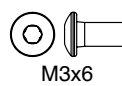
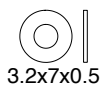
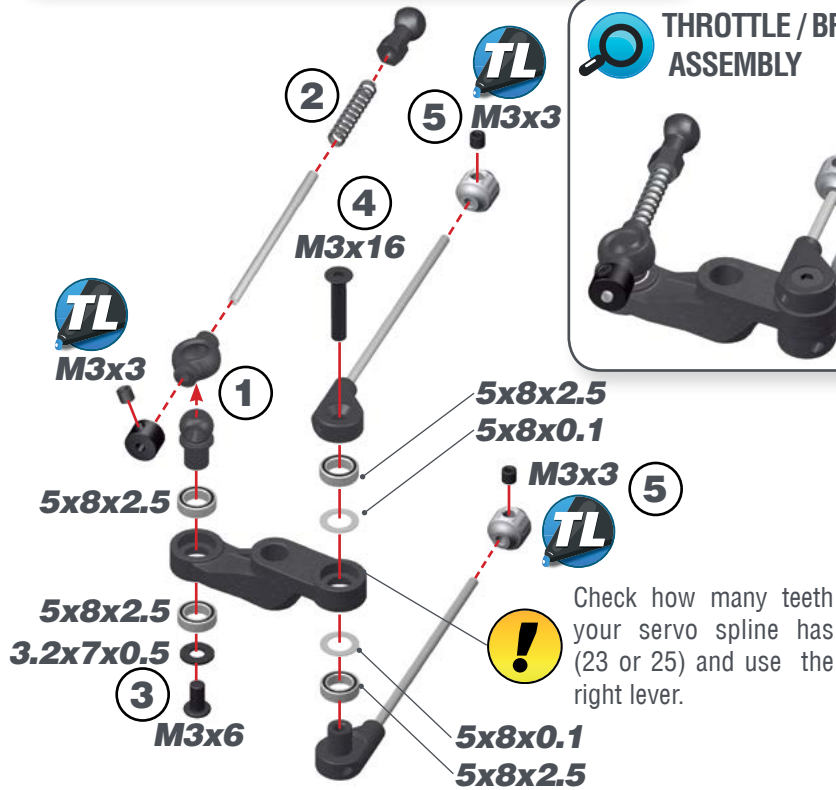

THROTTLE ASSEMBLY

Note the correct orientation of the brake balls.

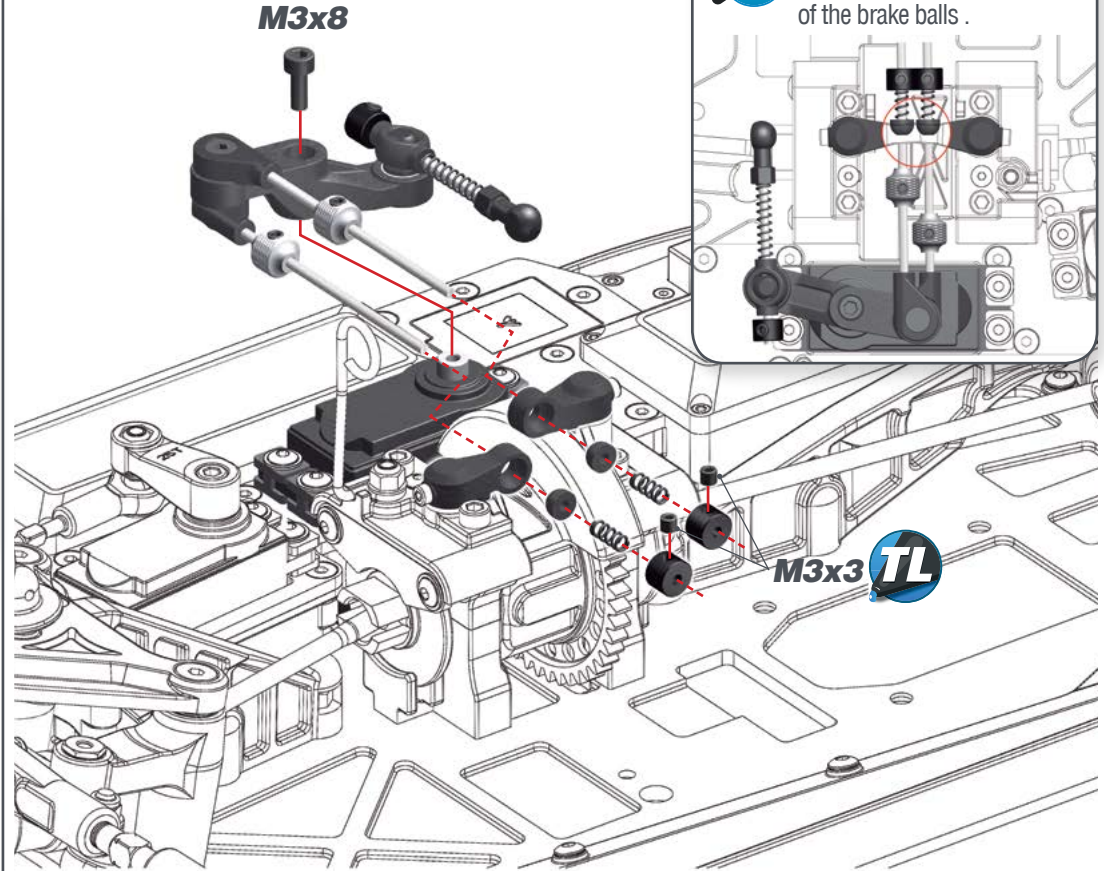
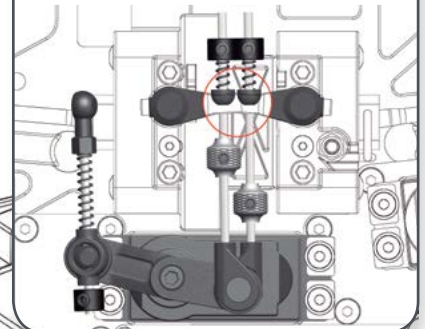

STEP 51

SHOCK BAG

STEP 52

51.1

! Use the correct shafts for the front and rear:
Front shaft: 62.35mm
Rear shaft: 71.25mm

51.2

! Use the correct shock body for the front and rear:
Front body: 50.25mm
Rear body: 58.15mm

51.3

! Use the long shaft with the long shock body and the short shaft with the short shock body.

2.5x6x0.5

TL

Nut M2.5

Use some silicone oil during the assembly.

SO

SO

Use some silicone oil during the assembly.

52.1

52.2

Insert the o-ring inside the spring collar.

1

2



SHOCKS LENGTH: Measure the shock length fully extended.

REAR

FRONT

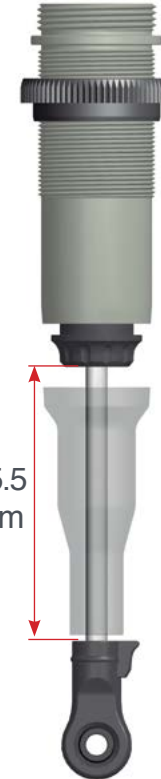

45.5 mm



37 mm

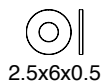

STEP 53

STEP 54

STEP 55

53.1

Push the membrane into the shock cap.



53.2

Prepare the screw with the o-ring

M2.3x4

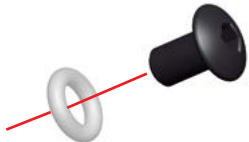

SHOCKS FILLING INSTRUCTIONS:

- **Step 54.1:** Pull the shock shaft to full stroke. Fill shock body with oil all the way to the top. Gently push and pull the shock shaft in and out 5 strokes. With the shaft at full extension, top off the shock with oil and install the cap.
- **Step 54.2:** With the shock at roughly 45 degree angle, position the opening in the cap facing upwards. Now, gently push the shock shaft all the way through its stroke. Excess oil and air will come through the bleeder hole. When the shock is at full compression, install the bleeder cap screw.
- **Step 54.3:** Pump the shock vigorously up and down 20 times to emulsify the oil for the final bleeding process.
- **Step 54.4:** With the shock angled as before and the shock shaft at full stroke, remove the bleeder cap screw and slowly press the shaft in one final time bleeding out any excess oil/air. Then retighten bleeder cap screw.

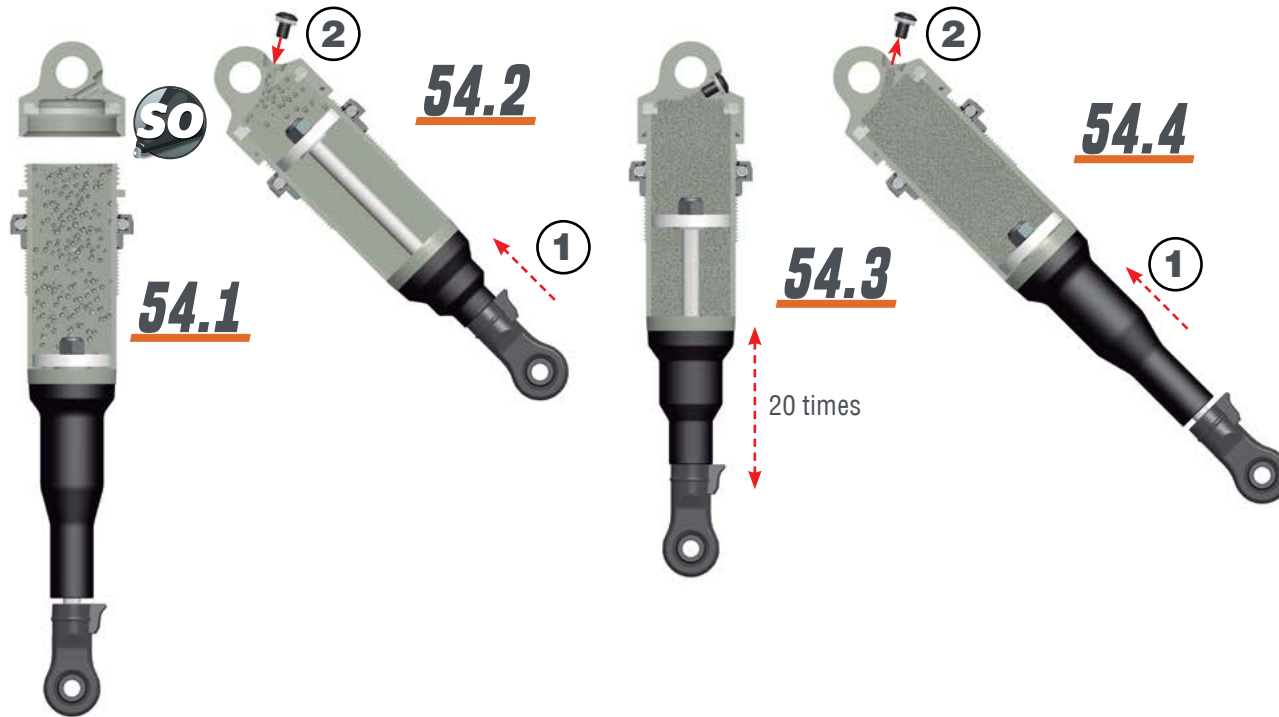

Spring Lengths:

Front-67.50mm
Rear-82.50mm



STEP 56

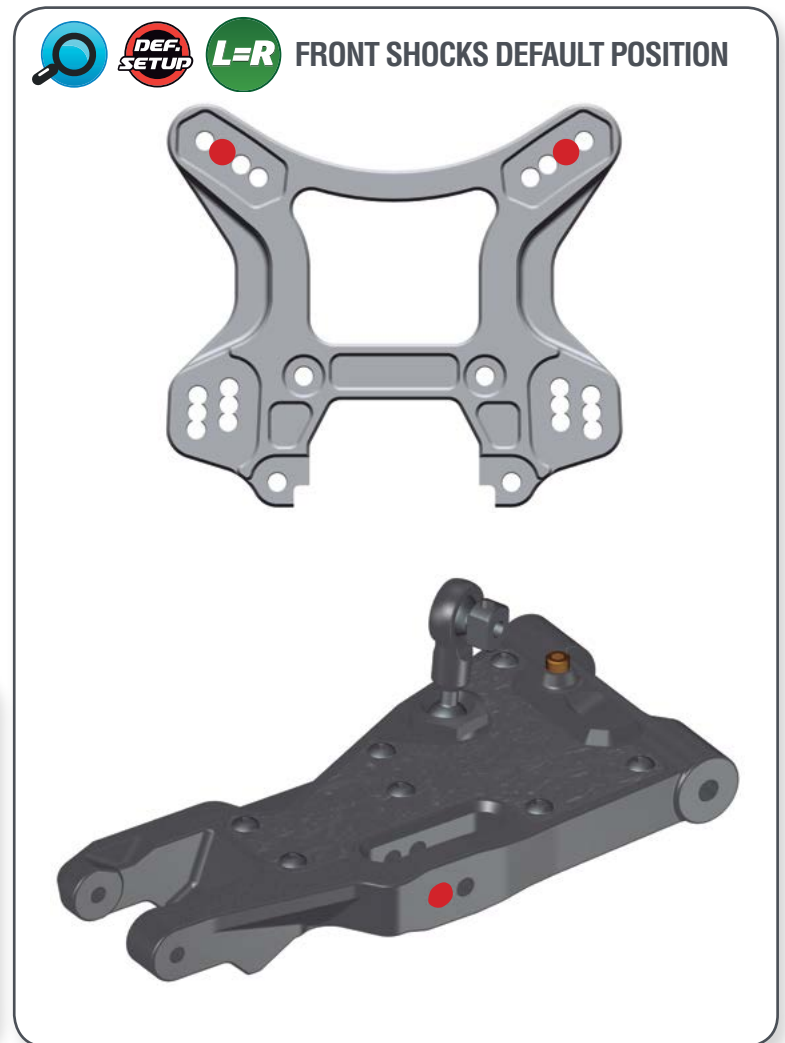
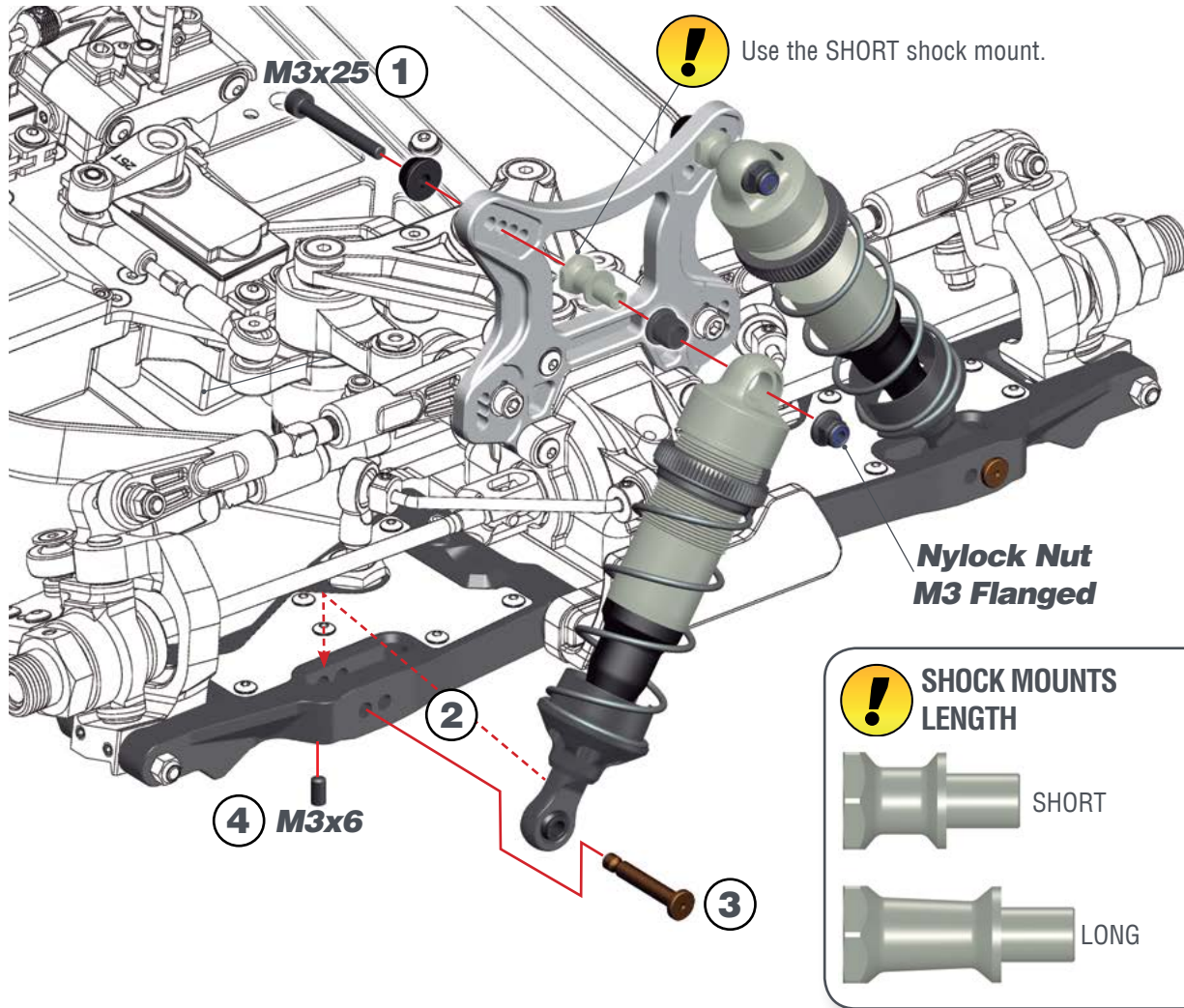

STEP 57

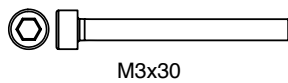
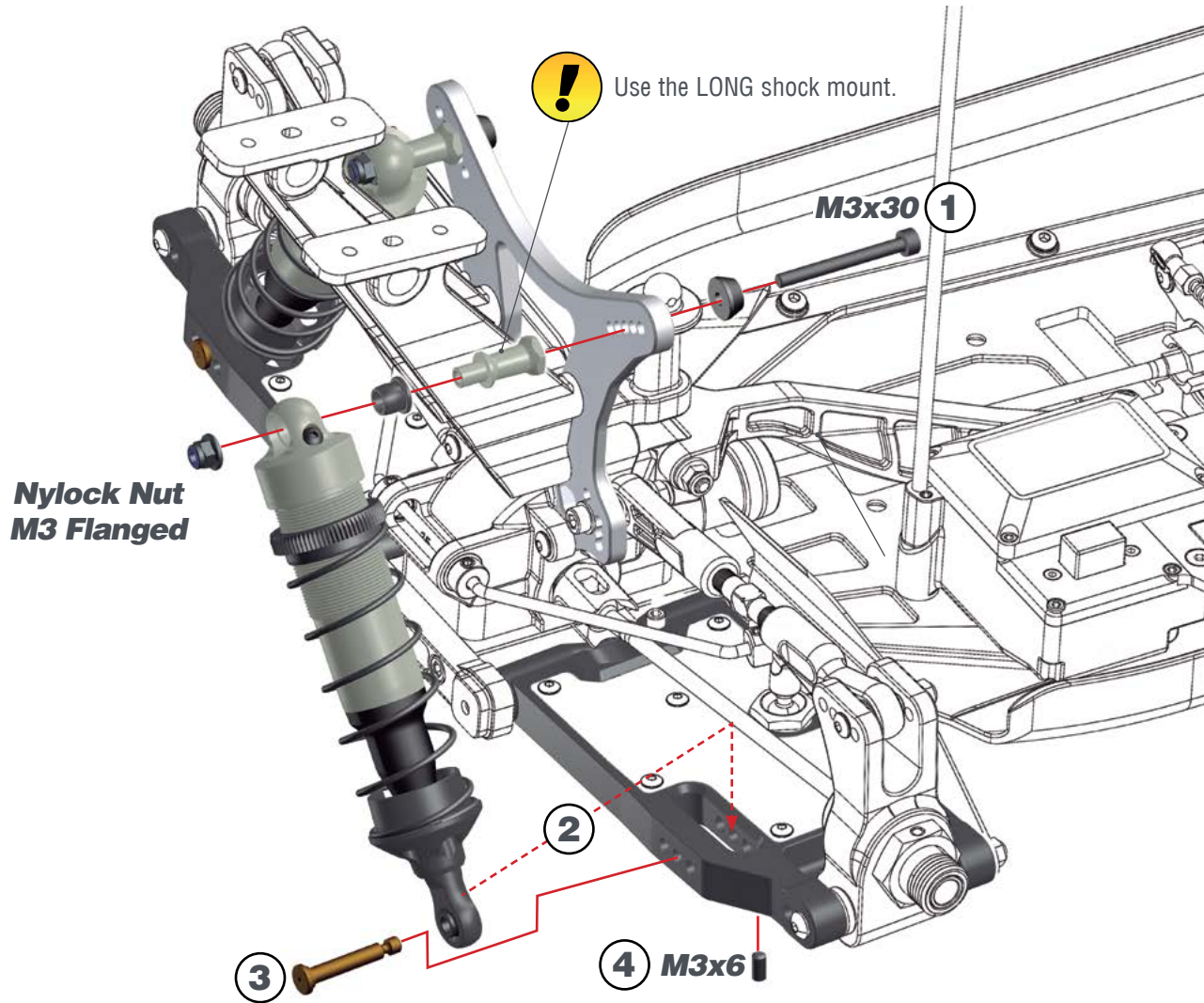

STEP 58

BAG 12

58.1



58.2



FUEL TANK INSERTS

The fuel-tank features a premounted 3cc insert. You can remove it if needed as shown.

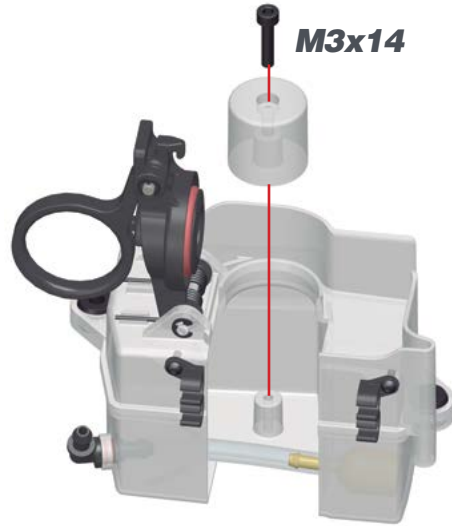

58.3

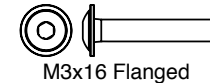
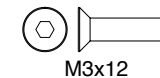
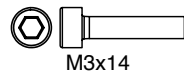
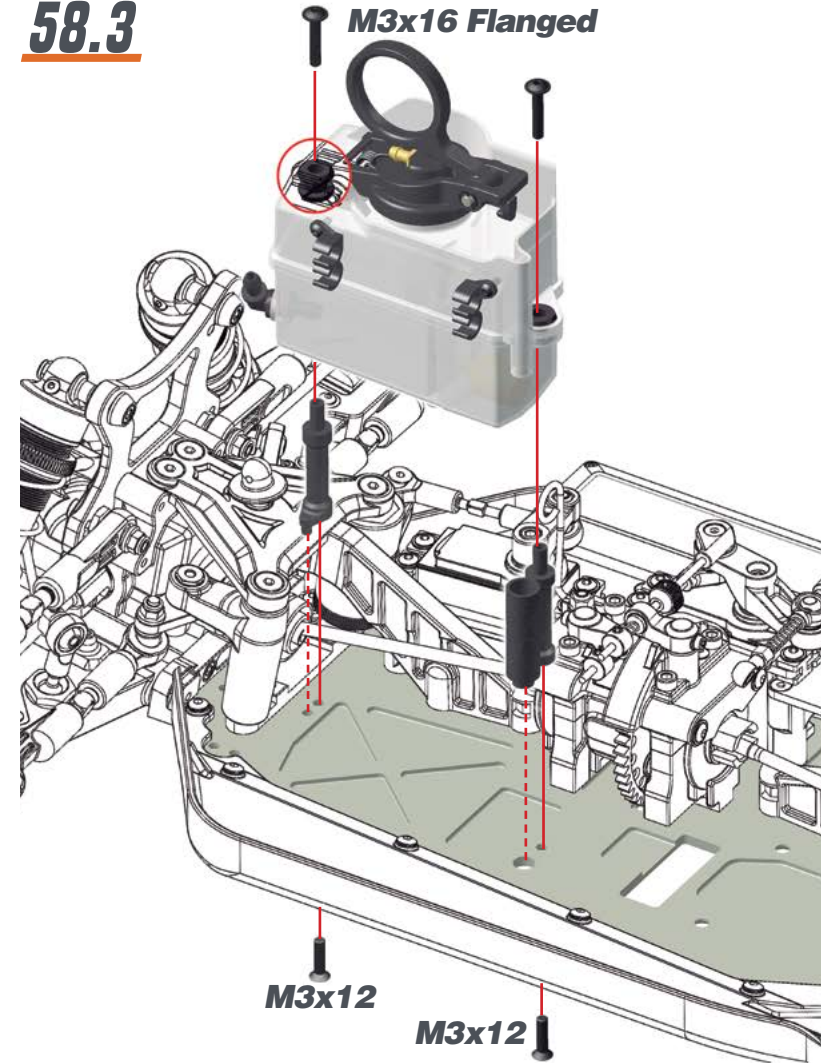

STEP 59

BAG 13

59.1 

Push the long leg of the spring in the inner hole of the clutch shoe.

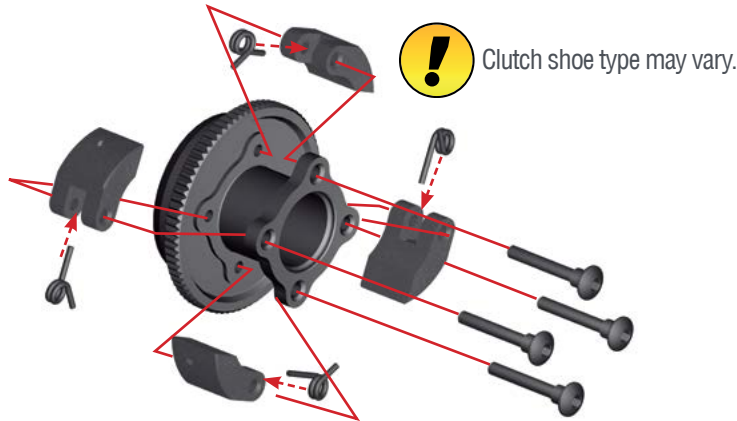

59.2

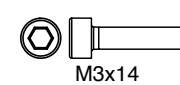
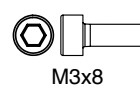
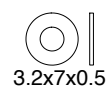
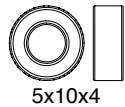
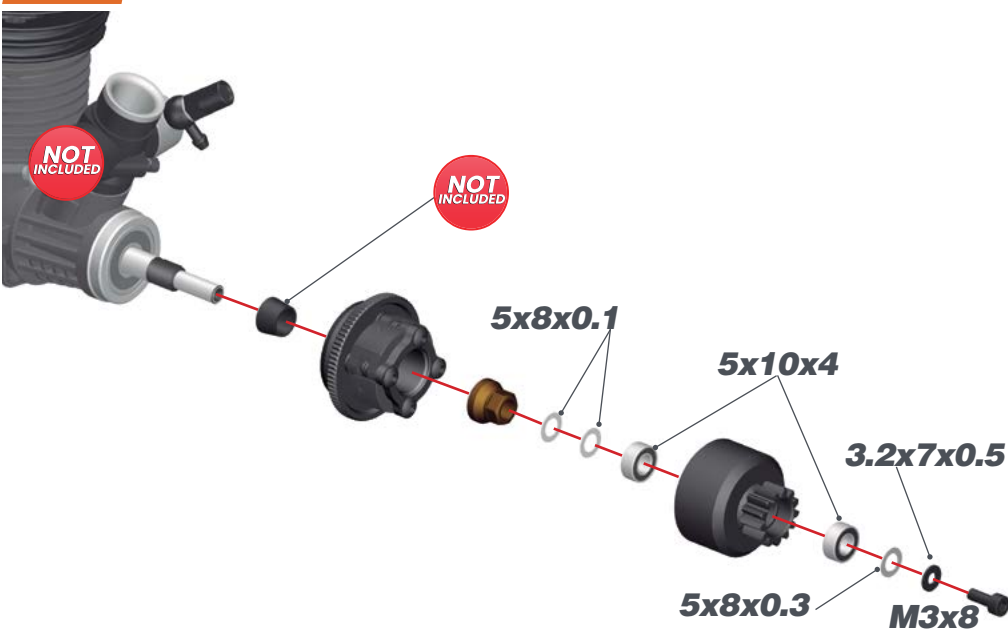

STEP 60

 Do not fully tighten the M3x14 screws till Step 61.

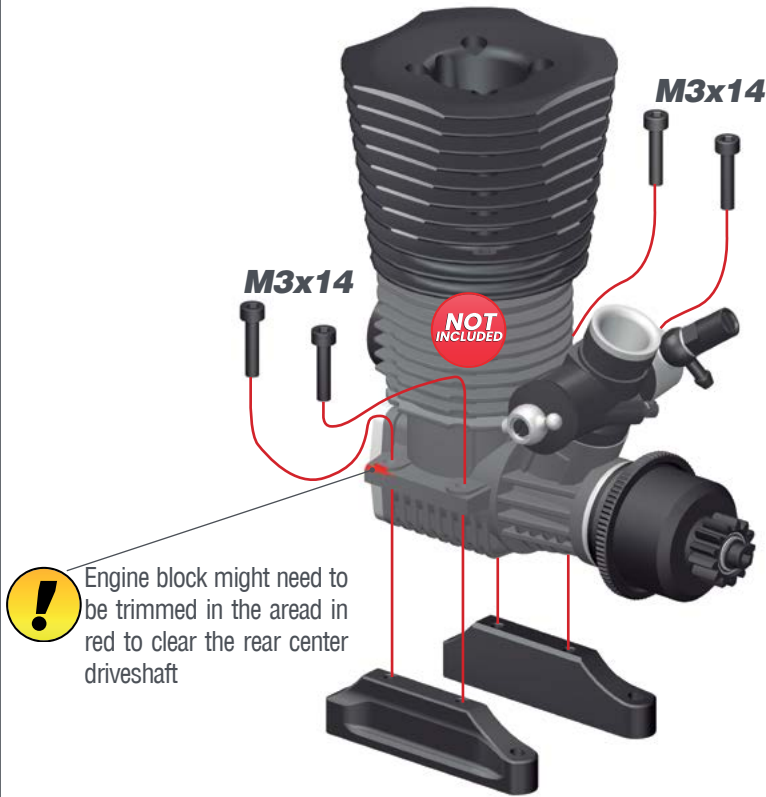

STEP 61



- 1- Assemble and fully tighten the M4x10 screws.
- 2- Position the engine in such way on the engine mount that the gearmesh is correct.
- 3- Fully tighten M3x14 screws assembled during the Step 60.

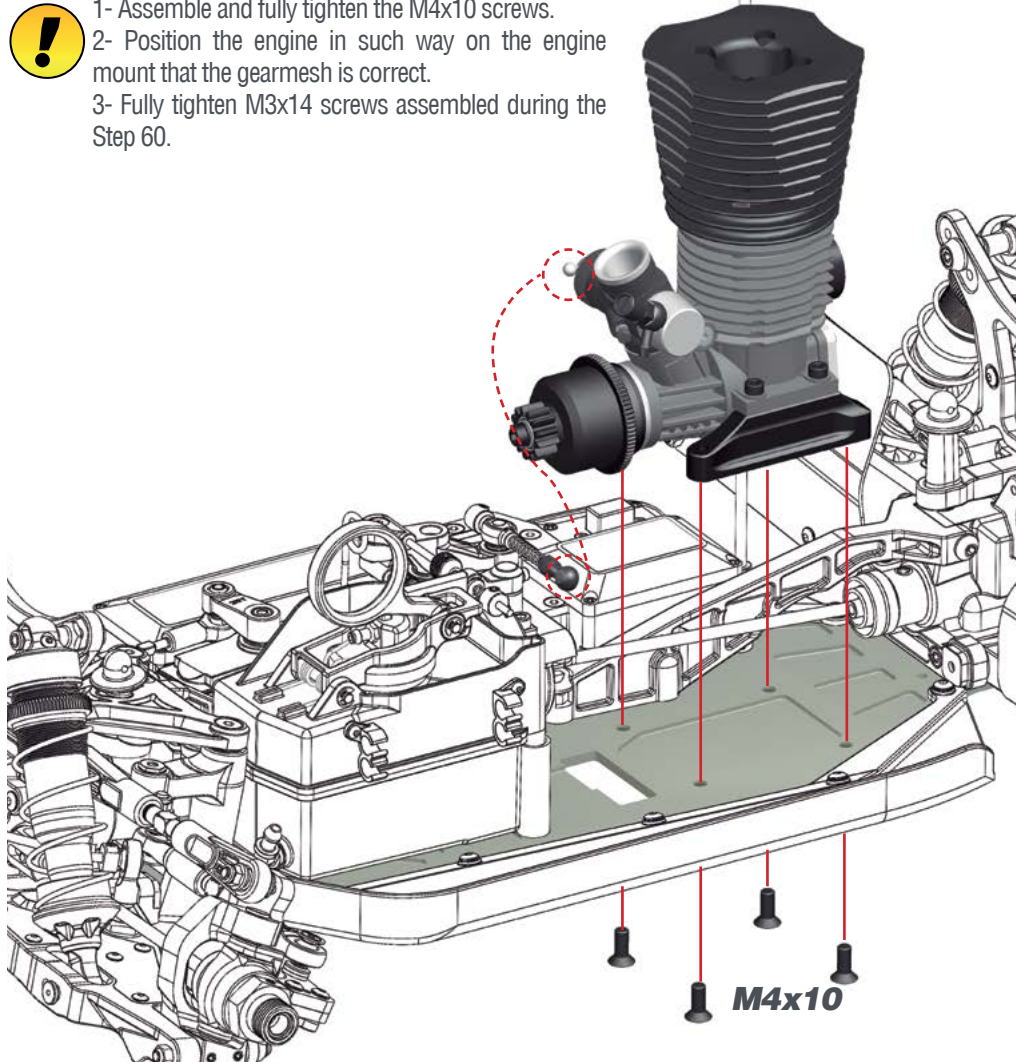

M4x10

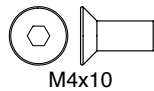

STEP 62

BAG 14

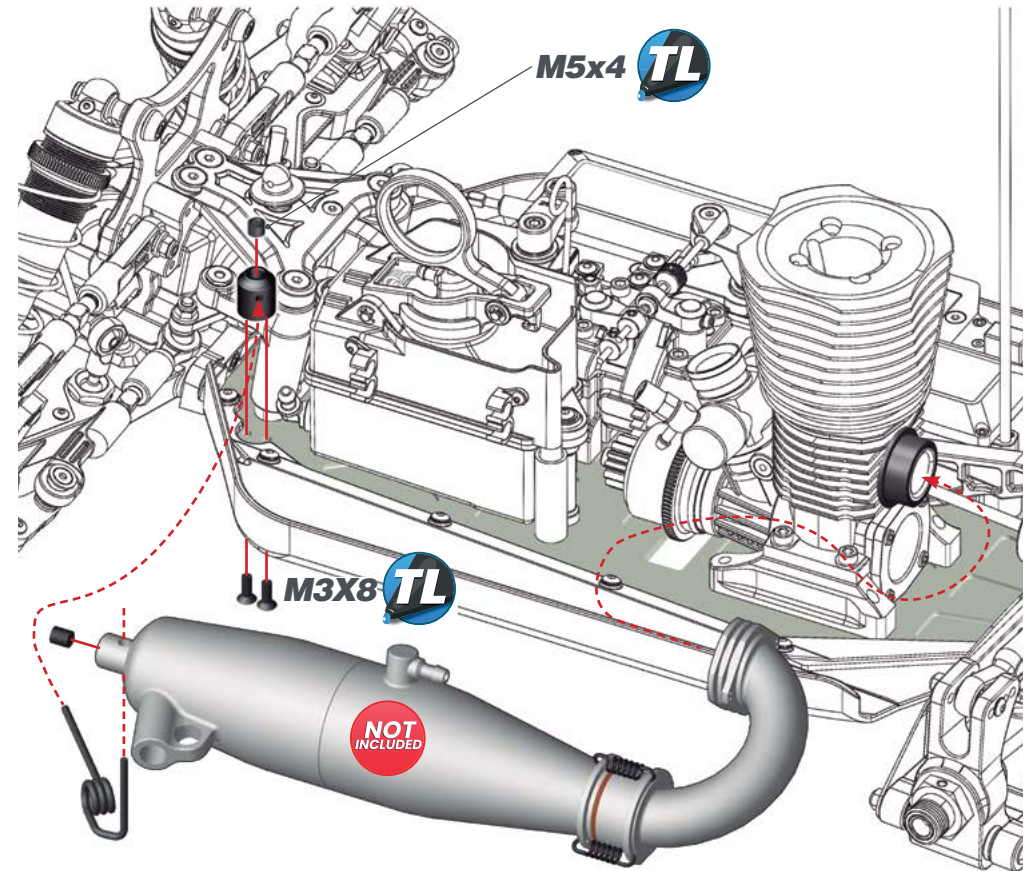

M5x4 TL

M3x8 TL

NOT INCLUDED



STEP 63

- !** 1- The fuel line illustrated in blue color is your tank to carburetor feed line.
2- The fuel line illustrated in orange color is your pipe to tank pressure line.

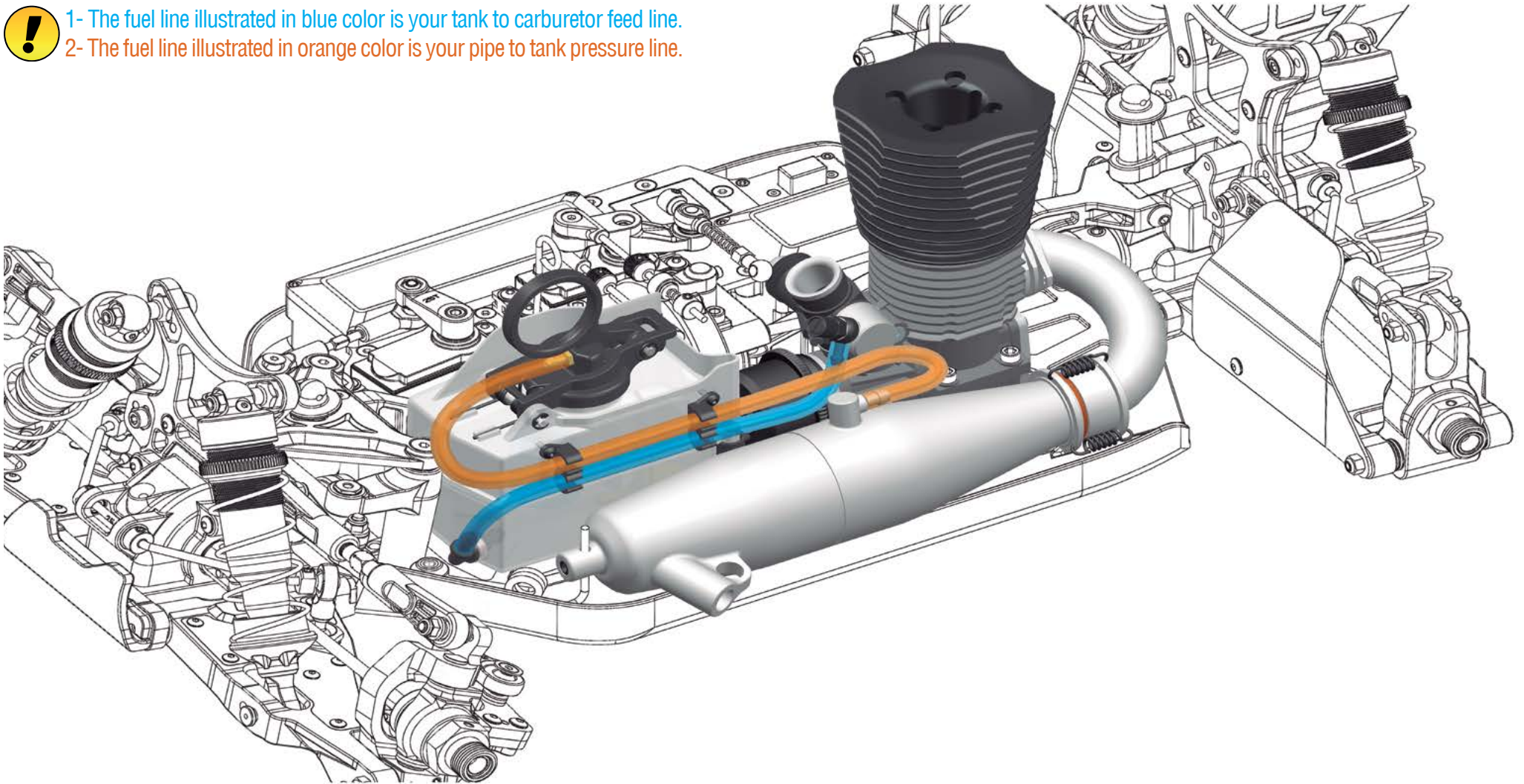

STEP 64

64.1  Oil the airfilter with a high quality foam-airfilter oil (not included). Do NOT use silicone oil.



64.2

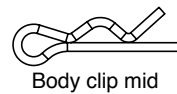
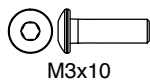
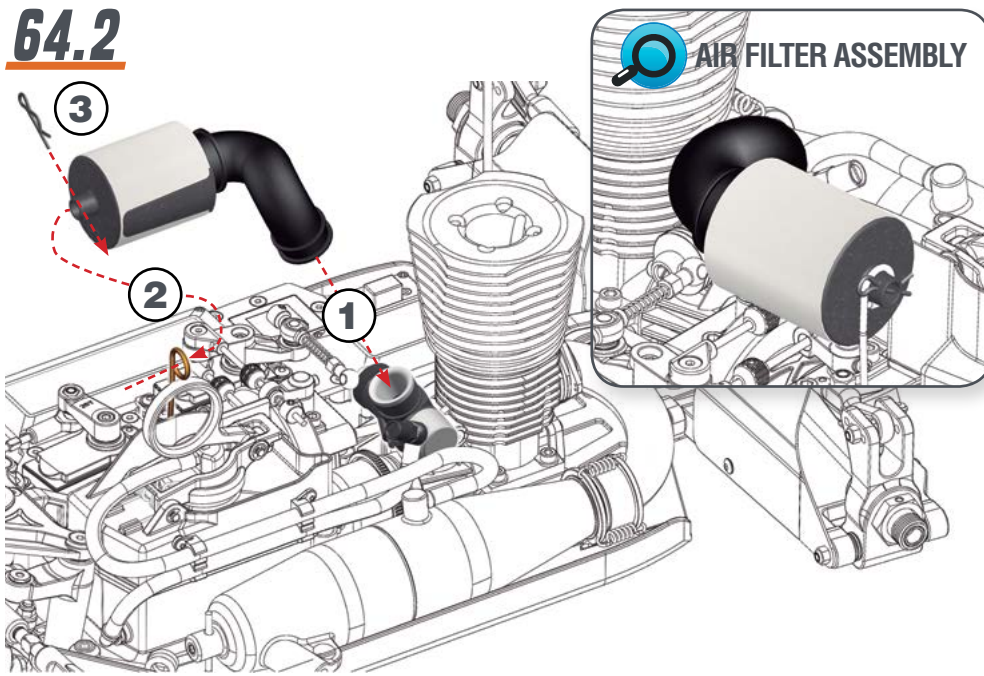

STEP 65

 **ANGLED WING SPACERS CHART**

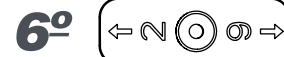
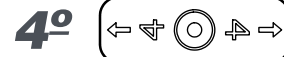
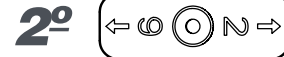

REAR  **FRONT**

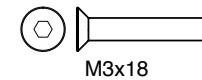
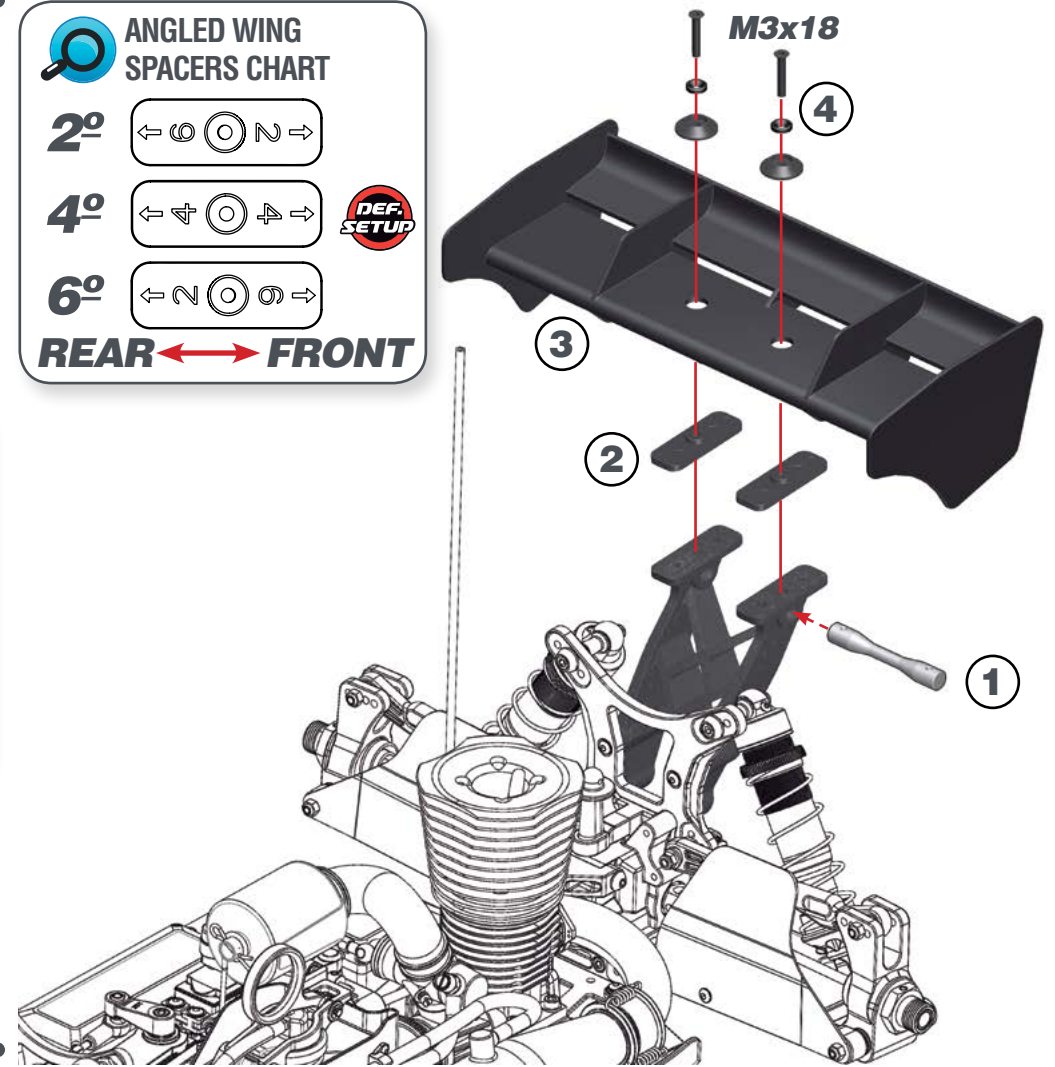

STEP 66

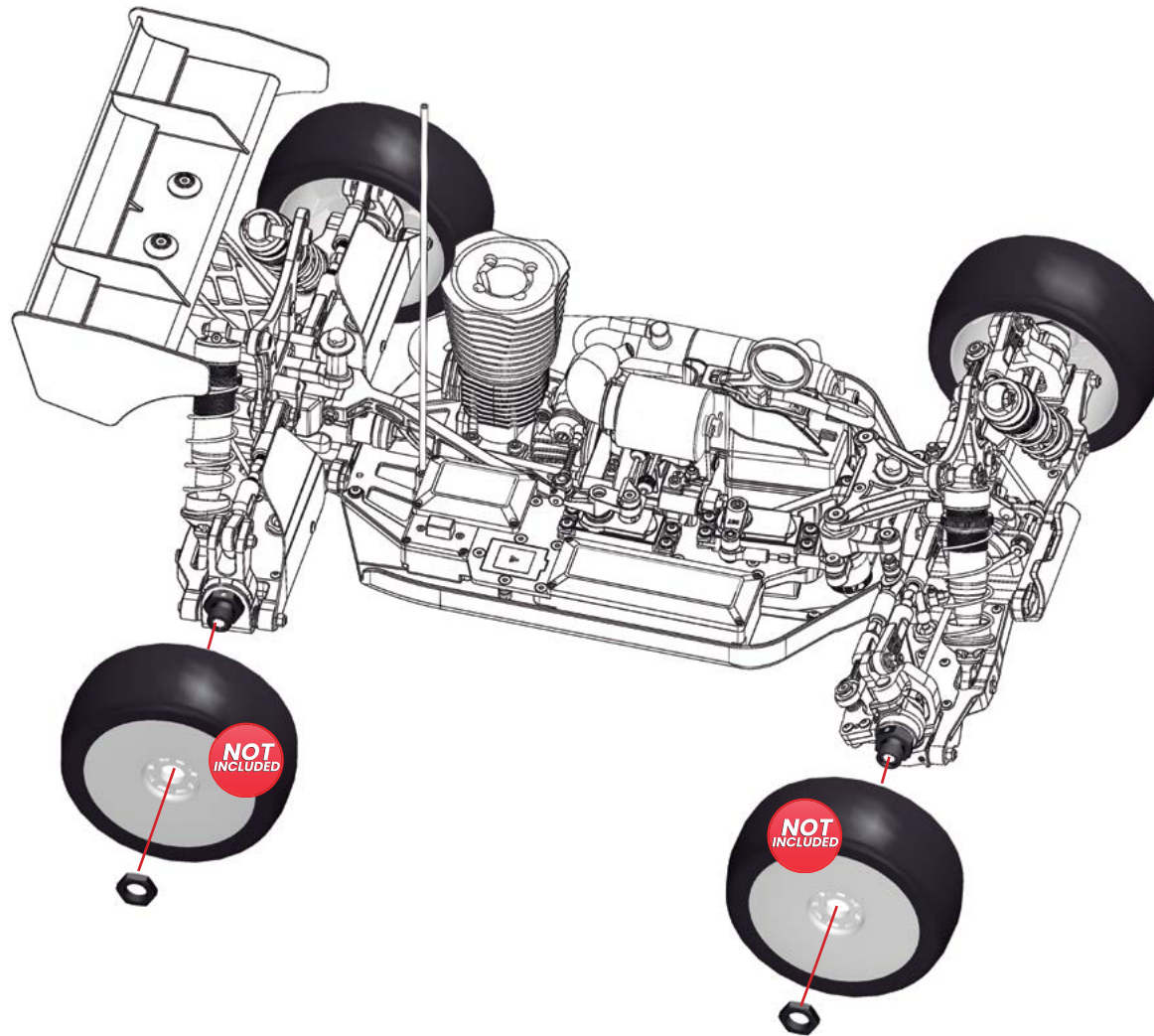

STEP 67

1- Cut the body along the cutting line with special scissors (not included). Make holes for the bodypost and antenna as needed with a body reamer (not included). Make a longer bodypost hole in the rear, to allow for chassis flex movement.

2- Before painting the body, apply the precut masking sheet elements to the inside of the body. Follow the cleaning & painting instructions supplied by the polycarbonate paint supplier you choose.

3- Apply the Serpent and Cobra logo-decals on the body and wing.

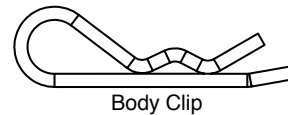
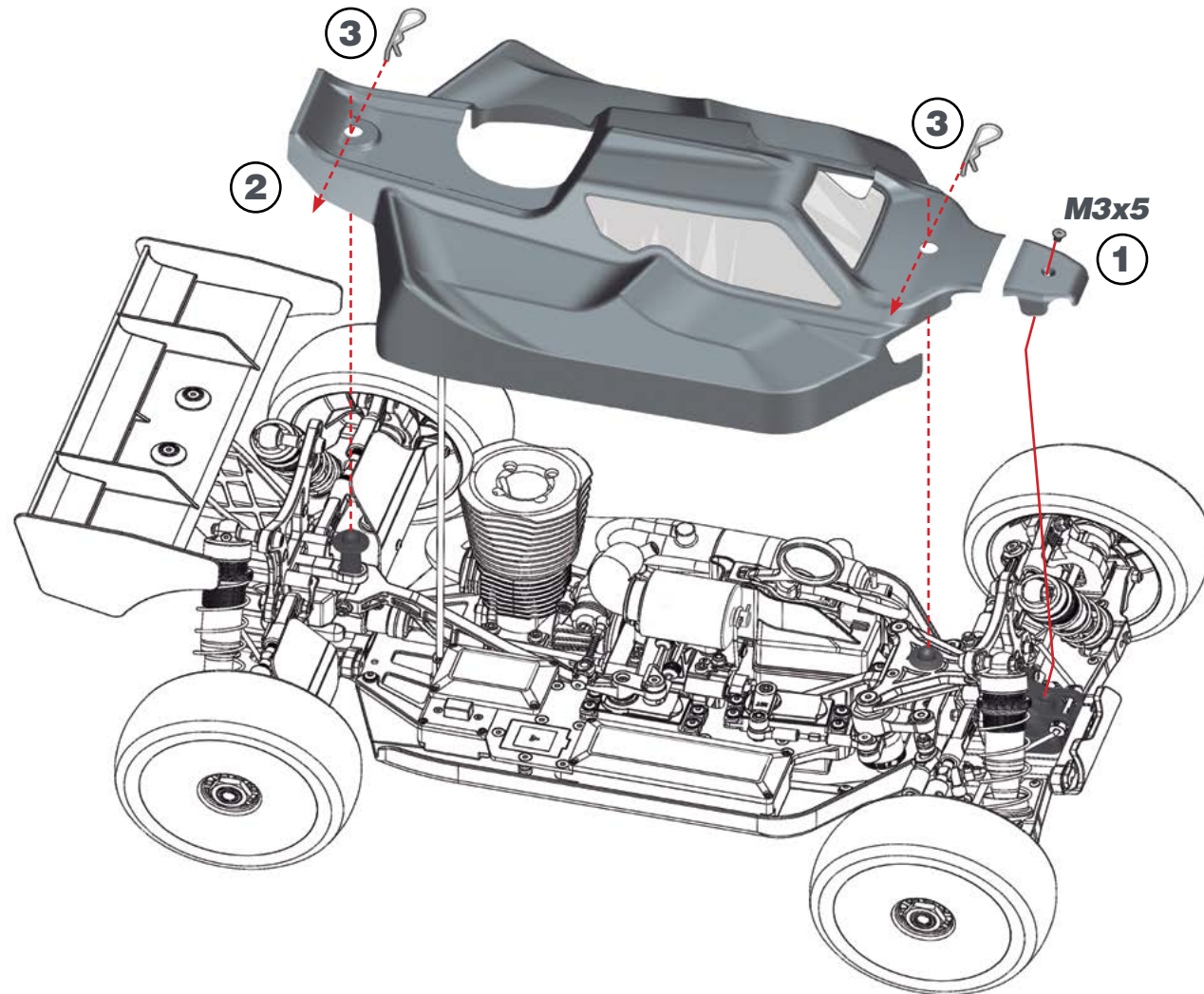

INDEX

<i>DIFFERENTIALS EXPLODED VIEW</i>	46
<i>BRAKE ASSEMBLY EXPLODED VIEW</i>	47
<i>CENTRAL CHASSIS COMPONENTS EXP VIEW</i>	48
<i>SHOCKS EXPLODED VIEW</i>	49
<i>FUEL TANK EXPLODED VIEW</i>	50
<i>STEERING EXPLODED VIEW</i>	51
<i>CLUTCH EXPLODED VIEW</i>	52
<i>RADIO EXPLODED VIEW</i>	53
<i>FRONT EXPLODED VIEW</i>	54
<i>REAR EXPLODED VIEW</i>	55
<i>FINAL 1 EXPLODED VIEW</i>	56
<i>FINAL 2 EXPLODED VIEW</i>	57

DIFFERENTIAL EXPLODED VIEW

SRX8
GEN 4

SERPENT

#601068 HTD diff set 44T fr/rr SRX8
#601069 HTD diff set 46T center SRX8



601280 HTD diff X-shaft alu SRX8



601072 HTD diff pin 10T alu (2) SRX8
601250 HTD diff set 44T SRX8 GT V2
601251 HTD diff gear 44T SRX8 GT V2

BRAKE ASSEMBLY EXPLODED VIEW

SRX8
GEN 4

SERPENT

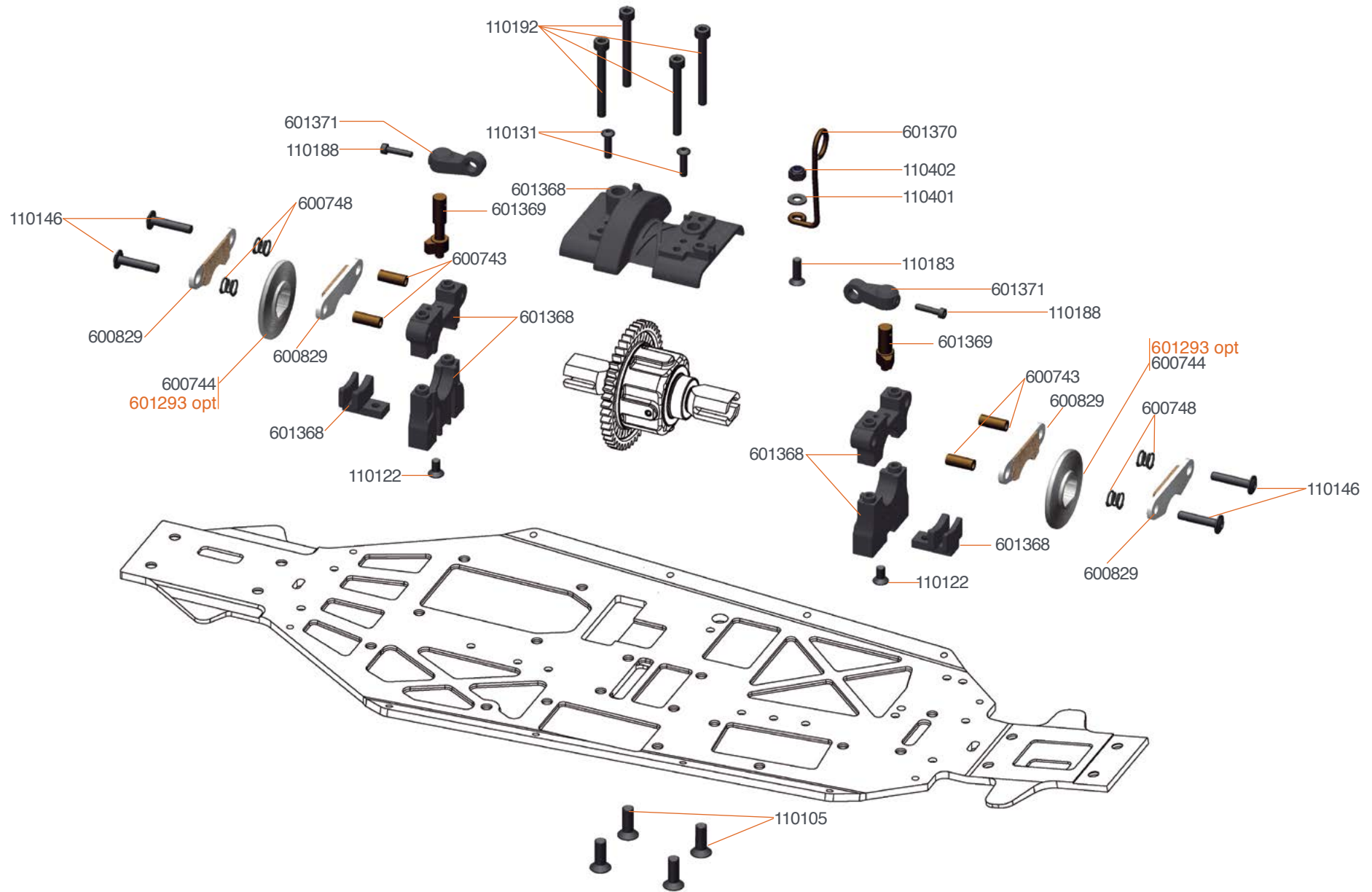

601293 Brakedisk pro set SRX8

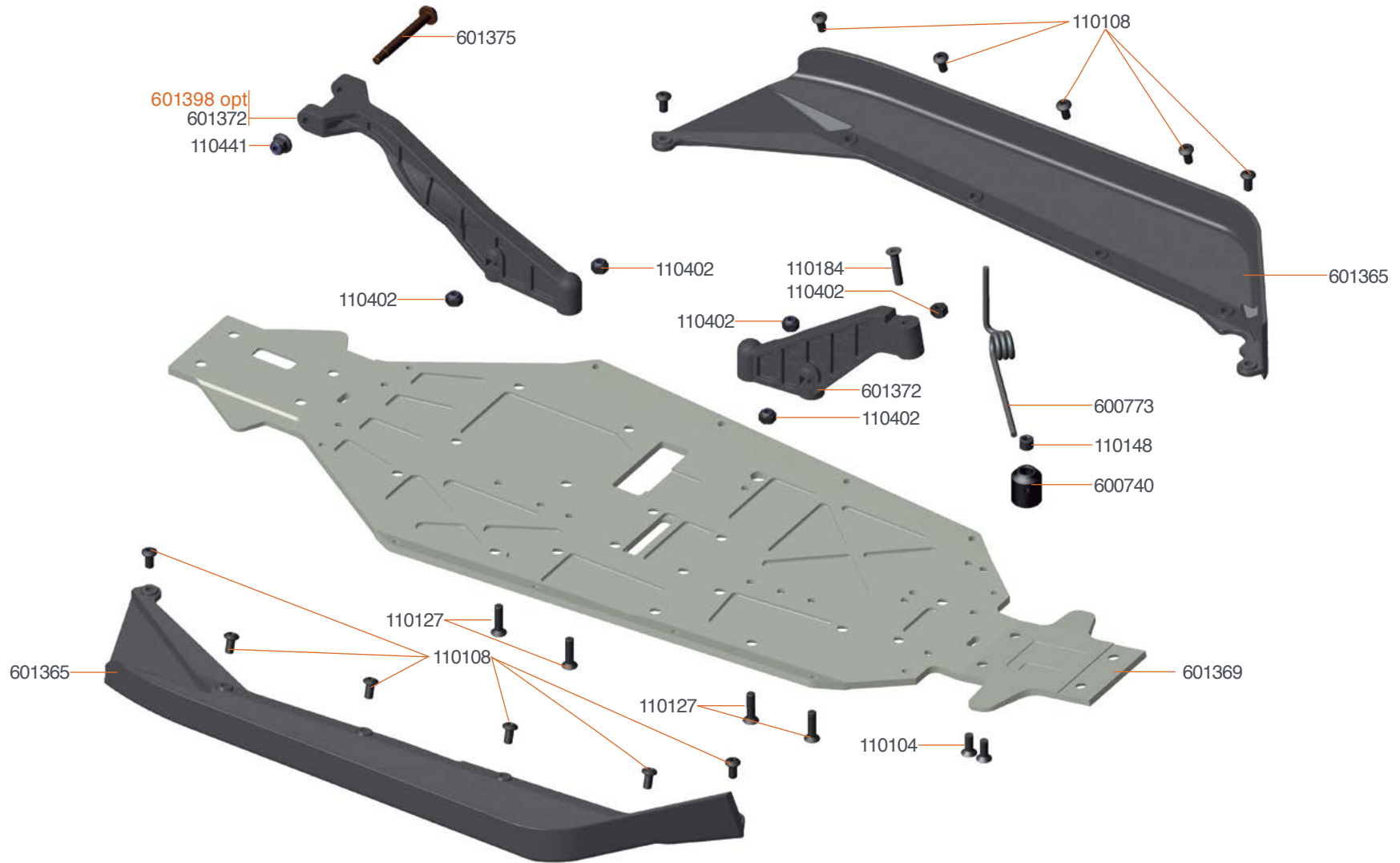

601398 Transmission brace flex RR SRX8 Gen4



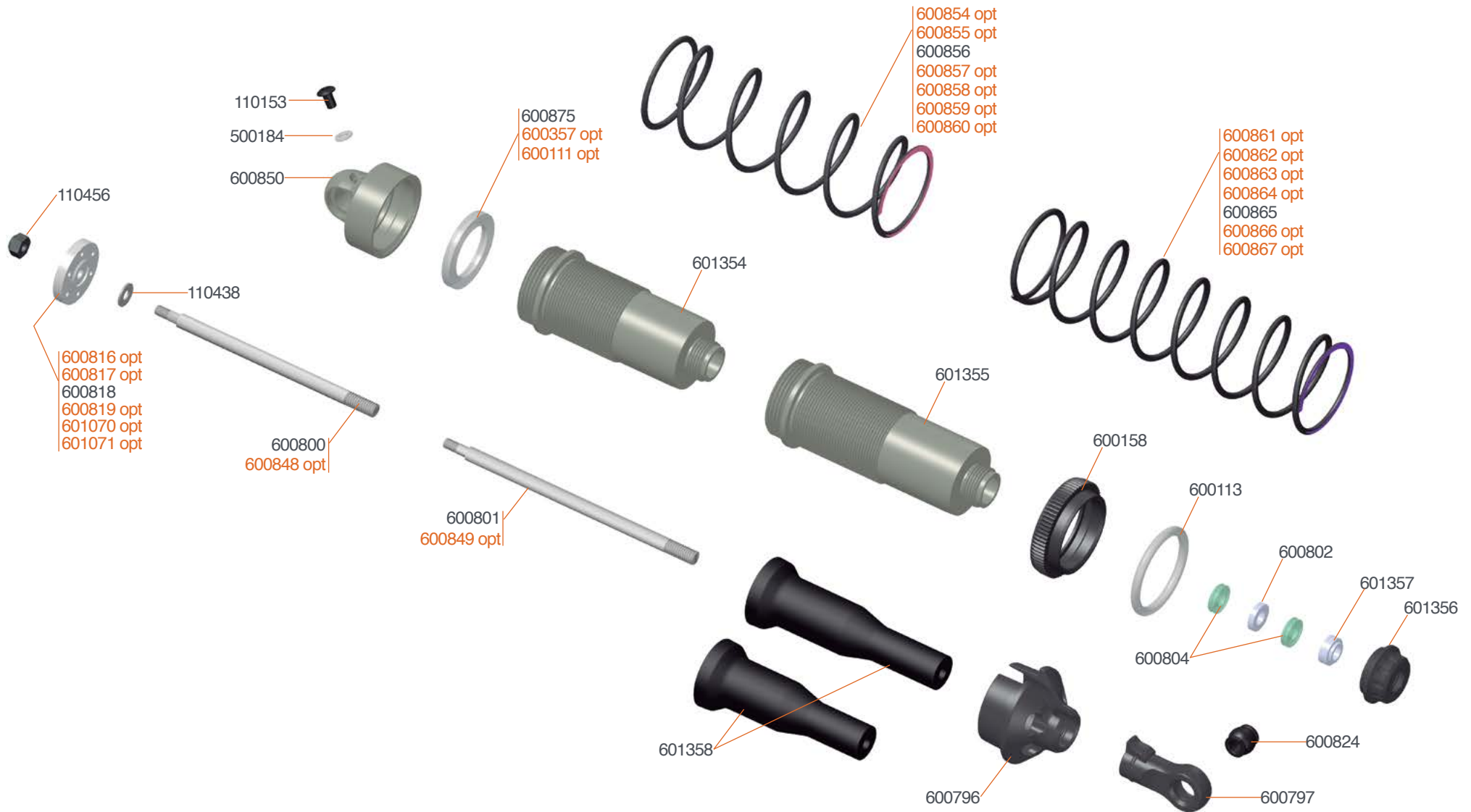

- 600854 Shockspring FR 4.5 lbs orange (2)
- 600855 Shockspring FR 4.7 lbs red (2)
- 600857 Shockspring FR 5.1 lbs blue (2)
- 600858 Shockspring FR 5.3 lbs purple (2)
- 600859 Shockspring FR 5.5 lbs green (2)
- 600860 Shockspring set FR (6x2)

- 600861 Shockspring RR 3.0 lbs orange (2)
- 600862 Shockspring RR 3.2 lbs red (2)
- 600864 Shockspring RR blue 3.6lbs (2)
- 600866 Shockspring RR 4.0 lbs green (2)
- 600867 Shockspring set RR (6x2)
- 600357 Membrane webbed silicone (4)

- 600816 Shock piston blank (4) SRX8
- 600817 Shock piston 5 holes (4) SRX8
- 600819 Shock piston 8 holes (4) SRX8
- 600848 Shock shaft FR TIN coated (2) SRX8
- 600849 Shock shaft RR TiN coated (2) SRX8
- 600111 Shock membrane (10)

- 600863 Shockspring RR pink 3.4lbs (2)
- 601070 Shock piston angled 1.2mm 8holes (4) SRX8
- 601071 Shock piston angled 1.3mm 8holes (4) SRX8



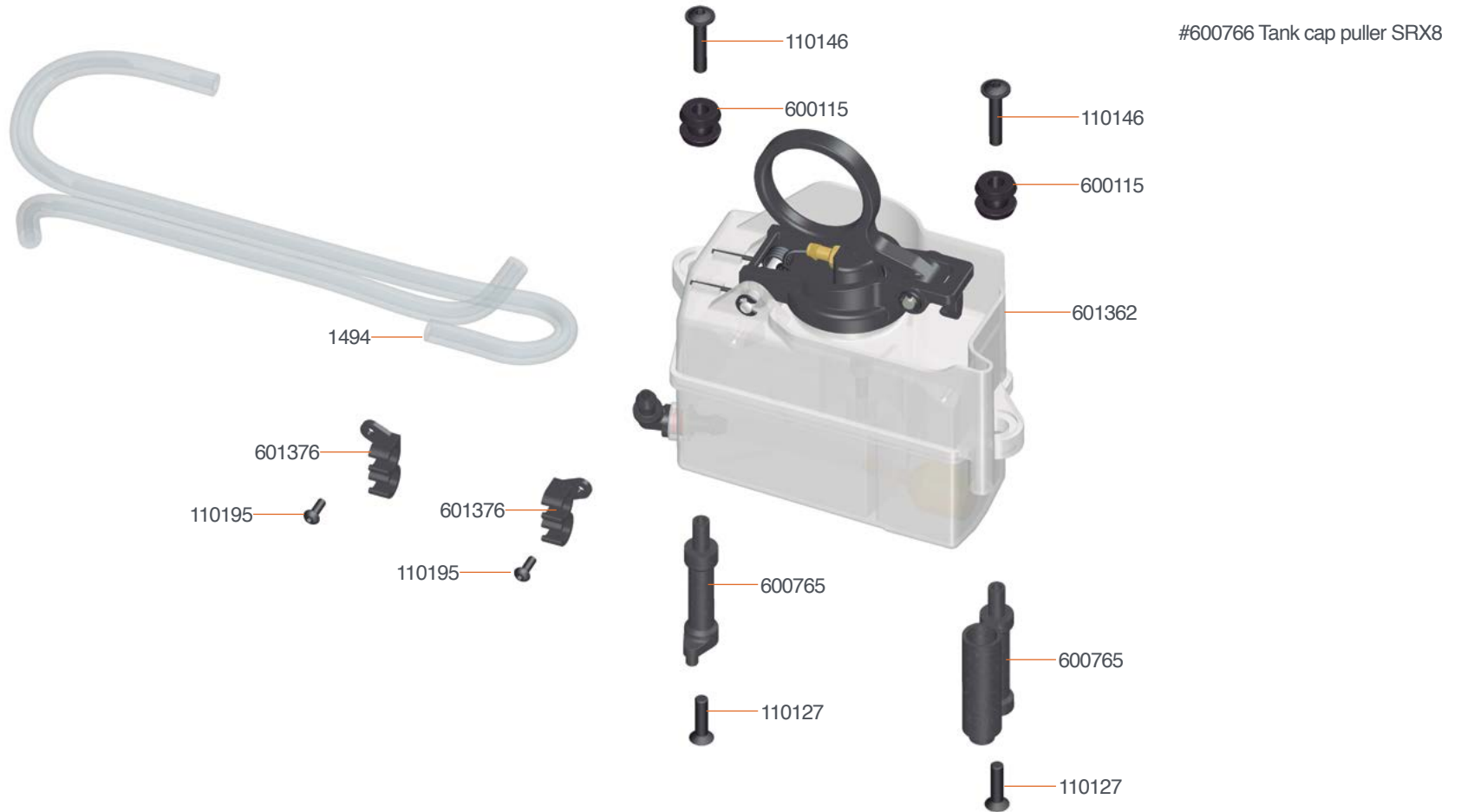

CLUTCH AND FILTER EXPLODED VIEW

SRX8
GEN 4

SERPENT

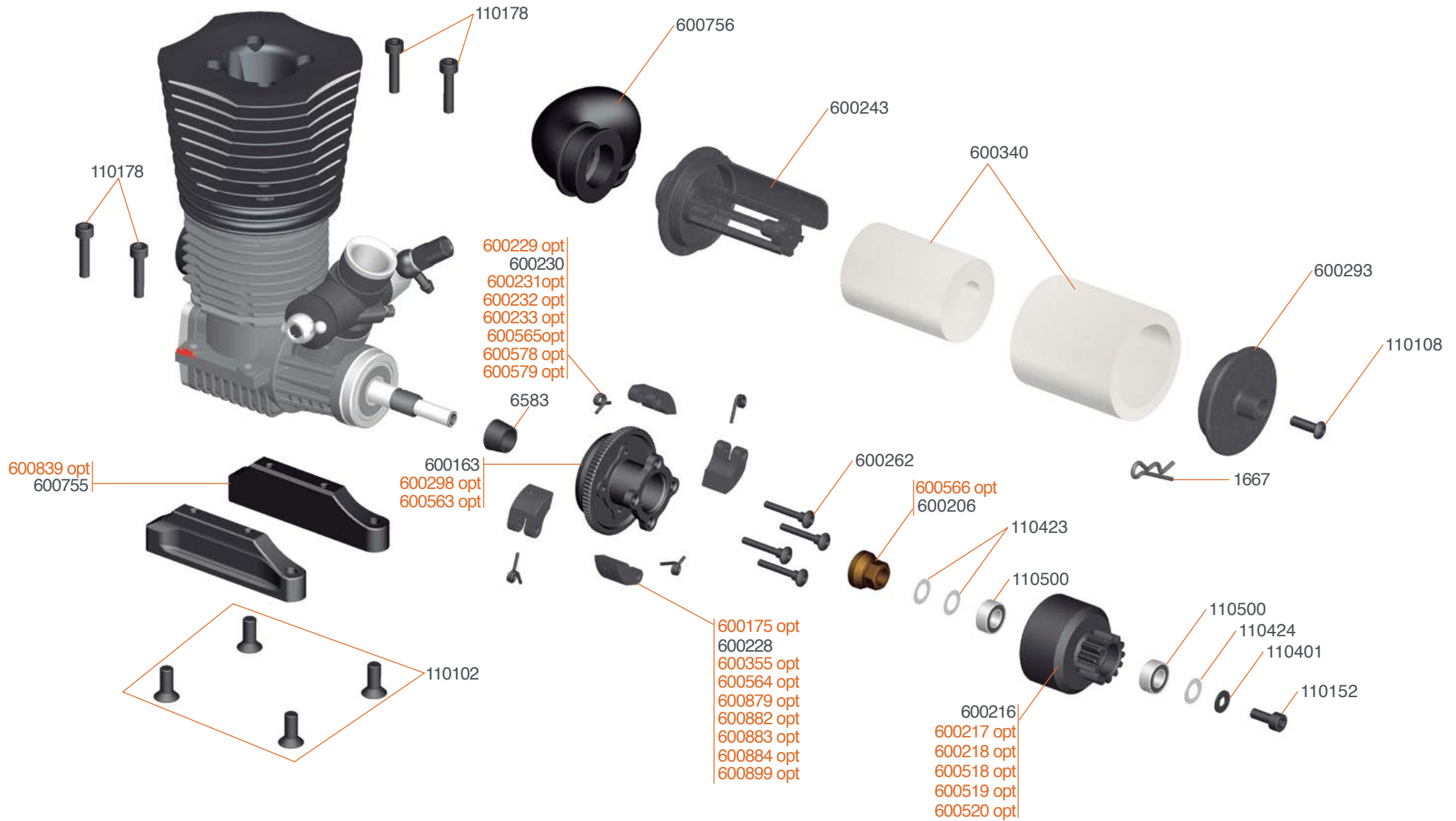

600518 Clutch bell 13T vented
600519 Clutch bell 14T vented
600229 Clutch spring soft 0.85mm (4)
600231 Clutch spring hard 0.95mm(4)
600232 Clutch spring X hard 1mm(4)
600233 Clutch spring set (4x4)
600175 Clutchshoe alu (4)

600355 Clutch shoe set Alu / Carbon (2+2)
600244 Clutch-set alu / carbon
600298 Flywheel steel
600563 Flywheel 3-pin alu
600565 Clutch spring 3-pin 0.9mm (3)
600578 Clutch spring 3-pin 1.0mm (3)
600579 Clutch spring 3-pin 1.0mm (3)

600564 Clutch shoe 3-pin carbon (3)
600566 Clutch nut 3-pin
600879 Clutch shoe yellow (4)
600882 Clutch shoe 4-pin alu 6061 (4)
600883 Clutch shoe 3-pin alu 6061 (3)
600884 Clutch shoe 3-pin alu 7075 (3)
600217 Clutch bell 14T

600218 Clutch bell 15T
600520 Clutch bell 15T vented

OPT

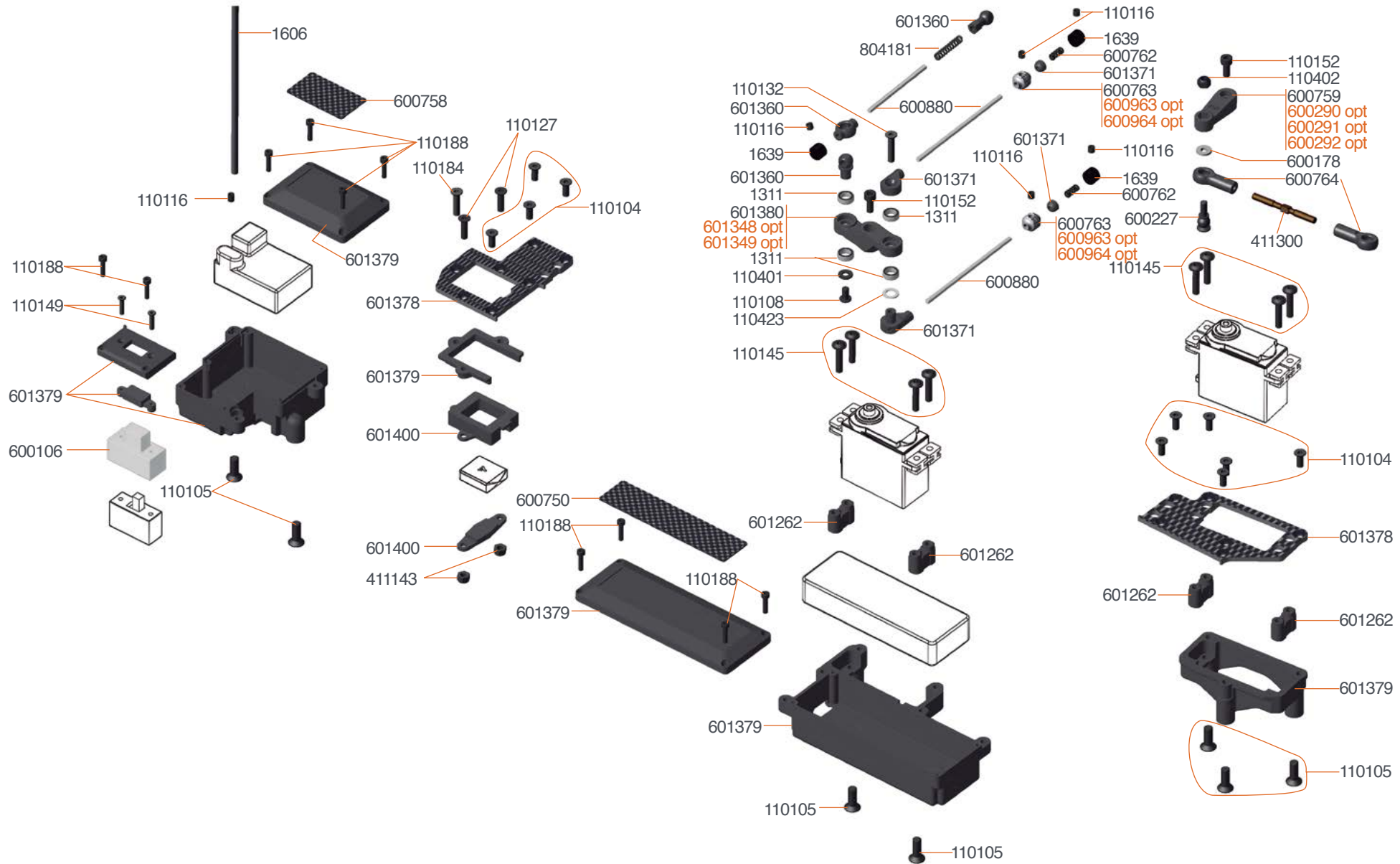

600290 Servo lever steering 23T alu
 600291 Servo lever steering 24T alu
 600292 Servo lever steering 25T alu

600963 Brake adjust collar alu orange (2) SRX8
 600964 Brake adjust collar alu black (2) SRX8
 601348 Throttle lever alu 23T SRX8 Gen4

601349 Throttle lever alu 25T SRX8 Gen4

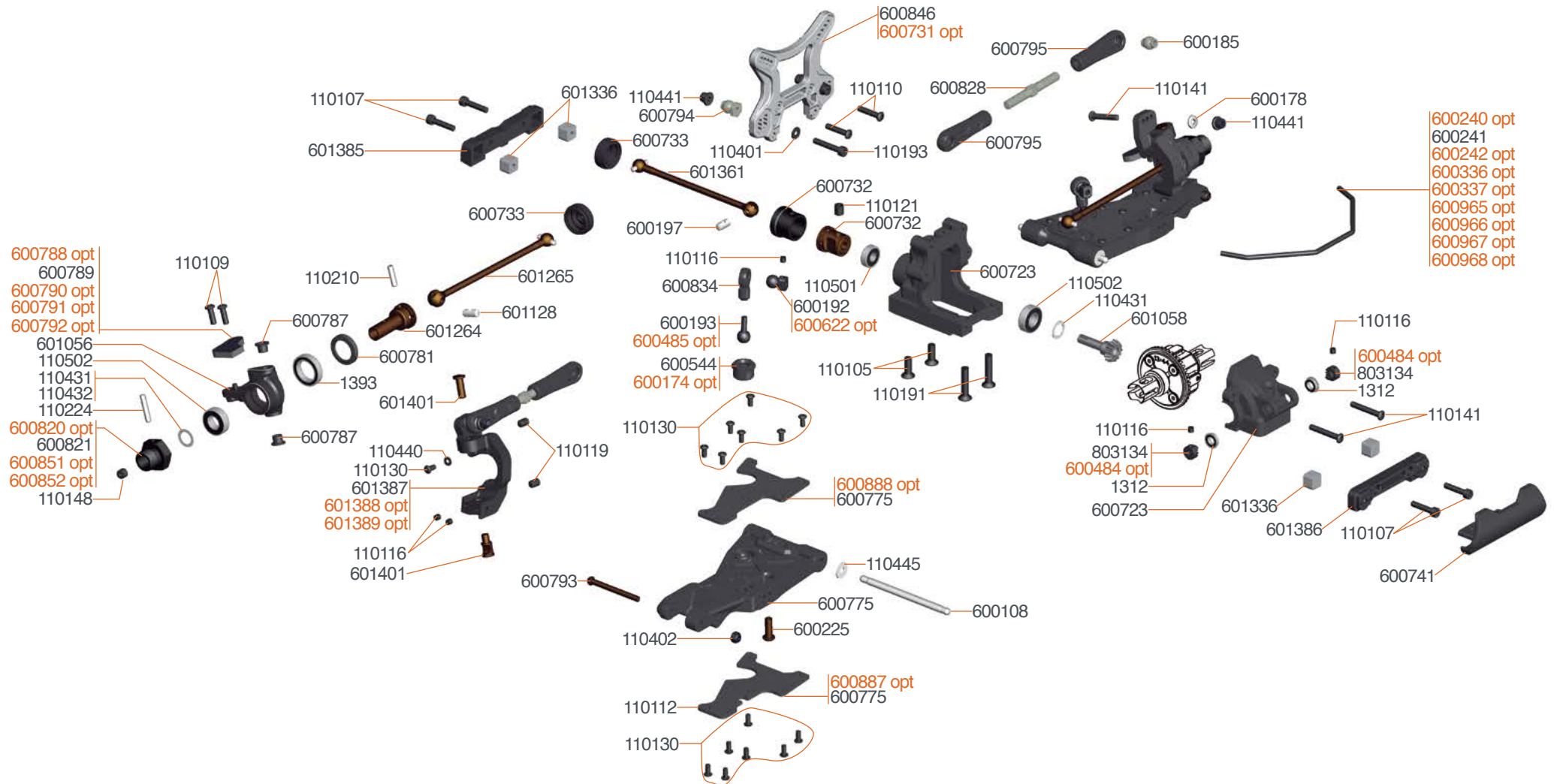

- 600174 Antirollbar nut (2)
- 600336 Antiroll bar front 1.8mm
- 600337 Antiroll bar front 2.0mm
- 600240 Antiroll bar front 2.3mm
- 600242 Antiroll bar front 2.7mm
- 600484 Antirollbar spacer 3mm alu (2)
- 600485 Pivotball threaded anti roll bar alu (2)

- 600622 Pivotball antirollbar alu (4)
- 600788 Steering arm 0 carbon (2) SRX8
- 600791 Steering arm 3 carbon (2) SRX8
- 600792 Steering arm 4 carbon (2) SRX8
- 600731 Shocktower FR carbon SRX8
- 600851 Wheelhexagon 0mm light (2) SRX8
- 600852 Wheelhexagon +1mm light (2) SRX8

- 600887 Wishbone insert carbon FR Lower SRX8 (2)
- 600888 Wishbone insert carbon FR Upper SRX8 (2)
- 600893 Overdrive diff pinion 13T SRX8
- 600965 Antiroll bar front 2.2 mm
- 600966 Antiroll bar front 2.4 mm

- 600967 Antiroll bar front 2.6 mm
- 600968 Antiroll bar front 2.8 mm
- 600820 Wheelhexagon 0mm (2) SRX8
- 600853 Gear Coupler alu SRX8
- 600970 Steering arm 2 carbon (2) SRX8
- 601388 C-hub 19deg KPI L+R alu SRX8 V2
- 601389 C-hub 21deg KPI L+R alu SRX8 V2



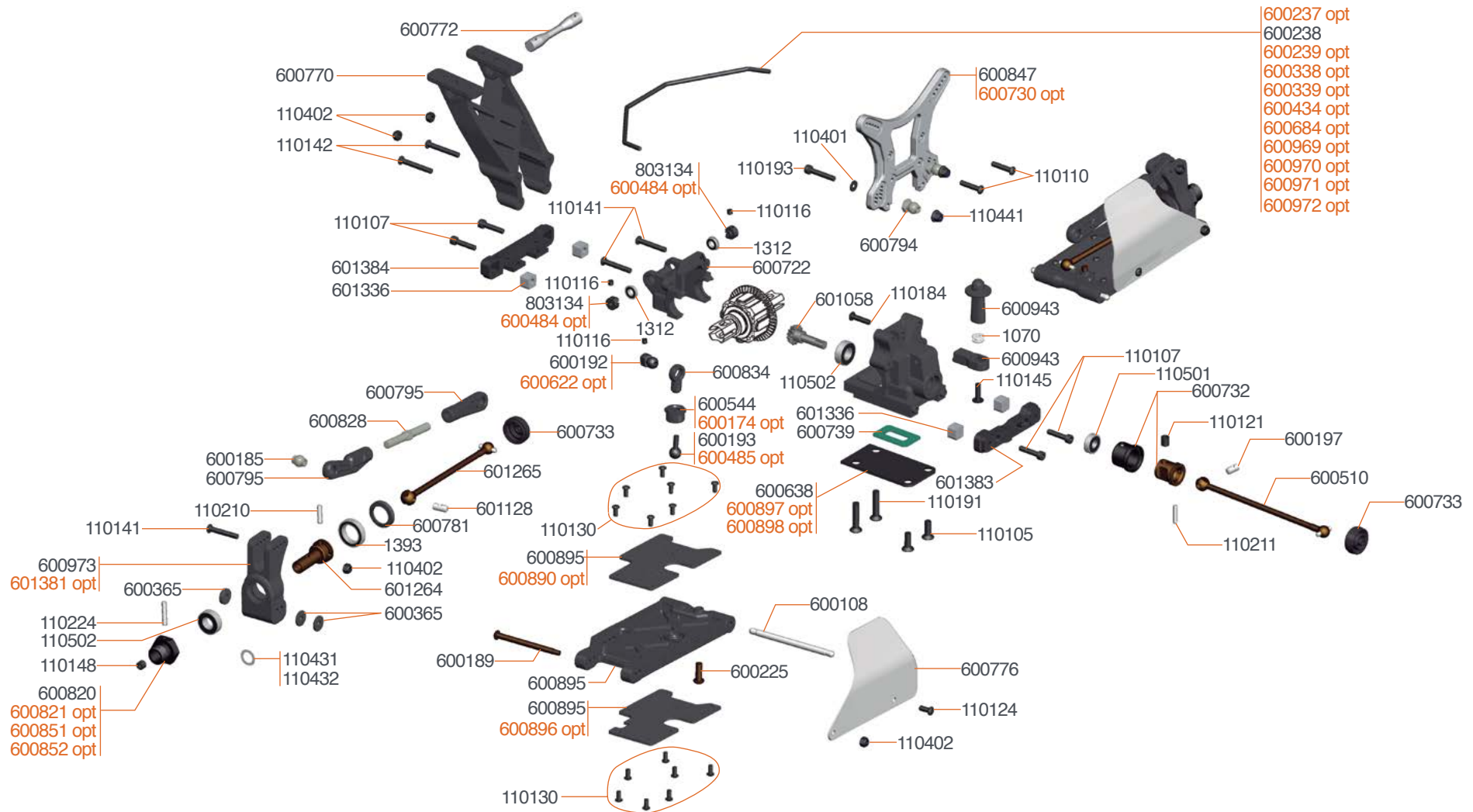

- 600237 opt
- 600238
- 600239 opt
- 600338 opt
- 600339 opt
- 600434 opt
- 600684 opt
- 600969 opt
- 600970 opt
- 600971 opt
- 600972 opt

- | | | | |
|---------------------------------------|-------------------------------------------------|---------------------------------------|--------------------------------------------------|
| 600174 Antirollbar nut (2) | 600485 Pivotball threaded anti roll bar alu (2) | SRX8 (2) | 600897 Skid plate alu SRX8 |
| 600338 Antiroll bar rear 1.8mm | 600622 Pivotball antirollbar alu (4) | 600893 Overdrive diff pinion 13T SRX8 | 600898 Skid plate carbon SRX8 |
| 600339 Antiroll bar rear 2.0mm | 600896 Wishbone insert carbon RR Lower V2 SRX8 | 600969 Antiroll bar rear 2.2 mm | 601381 Adjustable upright set alu SRX8 Gen4 |
| 600434 Antiroll bar rear 2.4mm | 600851 Wheelhexagon 0mm light (2) SRX8 | 600970 Antiroll bar rear 2.4 mm | 601382 Adjustable upright inserts (20) SRX8 Gen4 |
| 600237 Antiroll bar rear 2.3mm | 600852 Wheelhexagon +1mm light (2) SRX8 | 600971 Antiroll bar rear 2.6 mm | |
| 600239 Antiroll bar rear 2.7mm | 600853 Gear coupler alu SRX8 | 600972 Antiroll bar rear 2.8 mm | |
| 600684 Antiroll bar rear 3.0mm | 600890 Wishbone insert carbon RR Upper | 600730 Shocktower RR carbon SRX8 | |
| 600484 Antirollbar spacer 3mm alu (2) | | 600821 Wheelhexagon +1mm (2) SRX8 | |



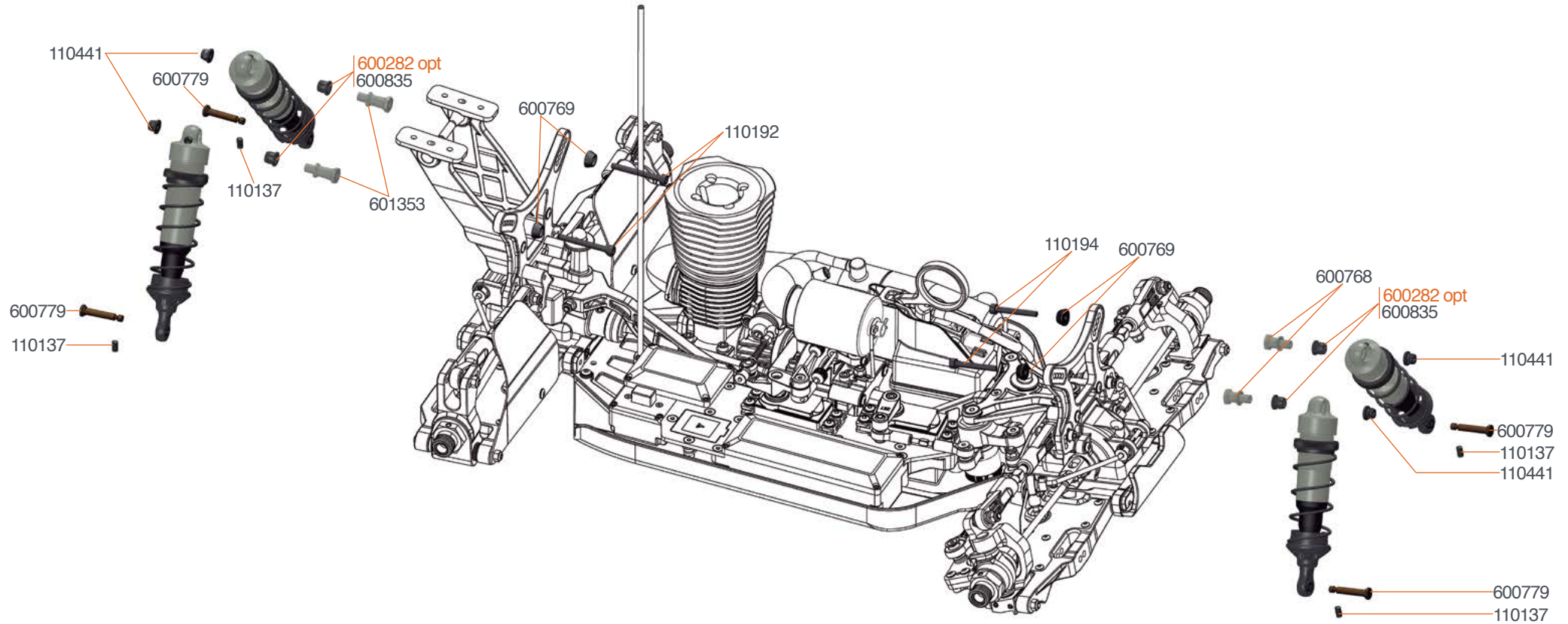

600282 Shock-pivot bushing delrin (4)



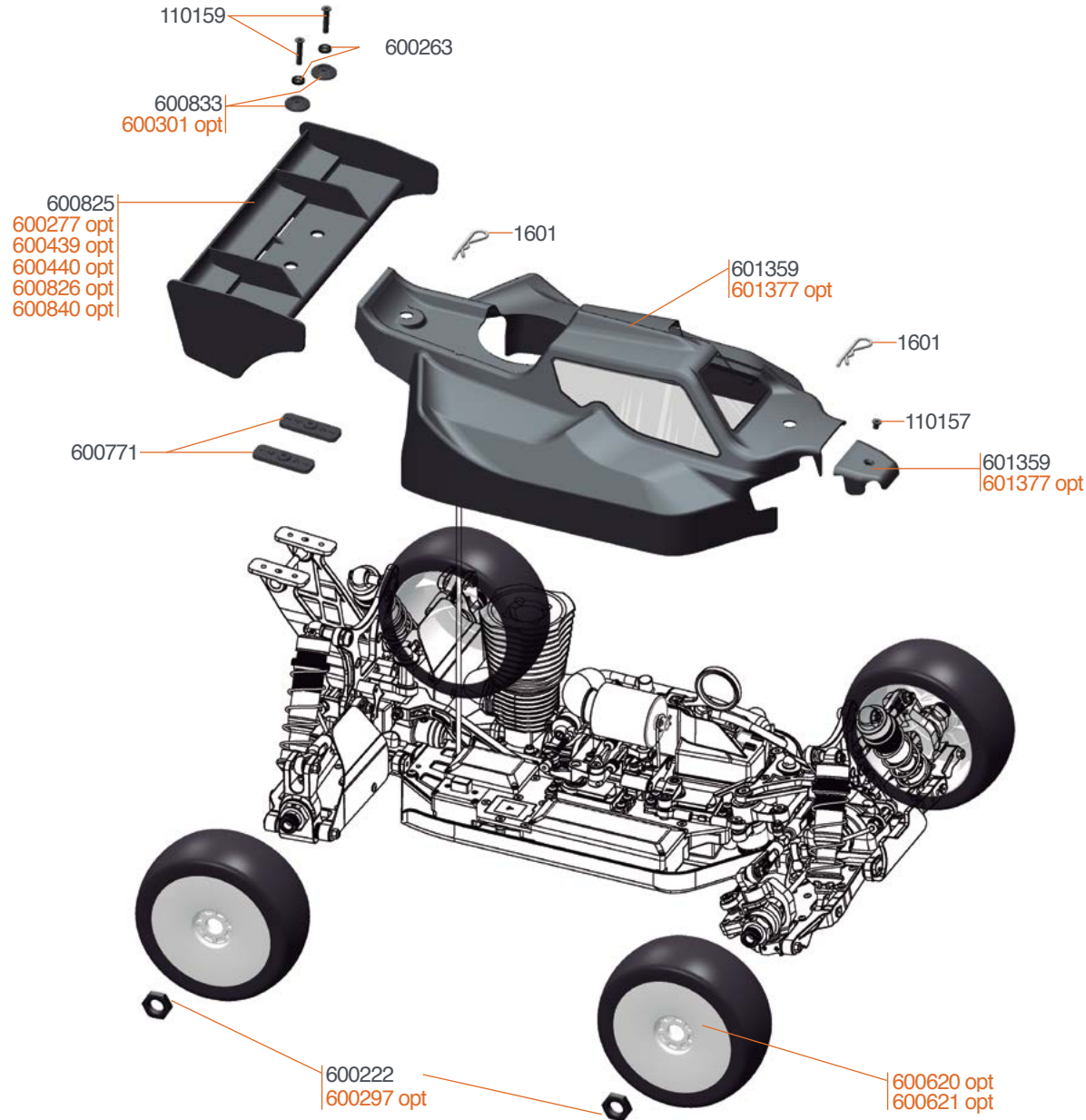

600297 Wheel-nut 17mm flanged/light (4)
600277 Wing black nylon
600439 Wing white low 811

600440 Wing black low 811
600826 Wing straight MD white 1/8
600840 Wing lexan HD with gurney 1/8

600620 Rim 1/8 buggy White (4)
600621 Rim 1/8 buggy Yellow (4)
601377 Body SRX8 Gen4 light

TEAM SERPENT NETWORK

SRX8 Gen4 SPARE PARTS



SRX8 Gen4 OPTIONALS PARTS



SERPENT TOOLS



SERPENT MERCHANDISING



SERPENT WEBSITE AND BLOG

www.serpent.com

www.teamserpent.com

www.dragon-rc.com

SERPENT PROMO PAGES <http://promo.serpent.com>

SERPENT SOCIAL MEDIA



www.facebook.com/SerpentMRC

1/8 OFF ROAD SCALE

SRX8

GEN4



Manual SRX8 Gen4 #83841-1

SERPENT